

CMOS-740HD

UNIVERSAL REAR VIEW CAMERA

INSTRUCTION MANUAL

CAMÉRA DE VUE ARRIÈRE UNIVERSELLE

MANUEL D'UTILISATION

UNIVERSAL RÜCKFAHRKAMERA

BEDIENUNGSANLEITUNG

UNIVERSELE ACHTERUITRIJCAMERA

GEbruIKSAANWIJZING

TELECAMERA PER RETROMARCIA UNIVERSALE

ISTRUZIONI PER L'USO

CÁMARA DE VISTA TRASERA UNIVERSAL

MANUAL DE INSTRUCCIONES

CÂMARA TRASEIRA UNIVERSAL

MANUAL DE INSTRUÇÕES

通用后视镜摄像头

使用说明书

JVCKENWOOD Corporation

Take the time to read through this instruction manual.

Familiarity with installation and operation procedures will help you obtain the best performance from your new Camera.

For your records

Record the serial number, found on the back of the unit, in the spaces designated on the warranty card, and in the space provided below. Refer to the model and serial numbers whenever you call upon your KENWOOD dealer for information or service on the product.

Model CMOS-740HD Serial number _____

US Residence Only

Register Online

Register your KENWOOD product at www.kenwood.com/usa/

For U.S.A

FCC CAUTION

Changes or modifications not expressly approved by the party responsible for compliance could void the user's authority to operate the equipment.

NOTE

- This equipment has been tested and found to comply with the limits for a Class B digital device, pursuant to part 15 of the FCC Rules. These limits are designed to provide reasonable protection against harmful interference in a residential installation.
- This equipment generates, uses and can radiate radio frequency energy and, if not installed and used in accordance with the instructions, may cause harmful interference to radio communications. However, there is no guarantee that interference will not occur in a particular installation. If this equipment does cause harmful interference to radio or television reception, which can be determined by turning the equipment off and on, the user is encouraged to try to correct the interference by one or more of the following measures:
 - Reorient or relocate the receiving antenna.
 - Increase the separation between the equipment and receiver.
 - Connect the equipment into an outlet on a circuit different from that to which the receiver is connected.
 - Consult the dealer or an experienced radio/TV technician for help.

Supplier's Declaration of Conformity

Trade Name: KENWOOD
Products: UNIVERSAL REAR VIEW CAMERA
Model Name: CMOS-740HD
Responsible Party: JVKENWOOD USA CORPORATION
2201 East Dominguez Street,
Long Beach, CA 90810, U.S.A.
PHONE: 310 639-9000

THIS DEVICE COMPLIES WITH PART 15 OF THE FCC RULES. OPERATION IS SUBJECT TO THE FOLLOWING TWO CONDITIONS:

- (1) THIS DEVICE MAY NOT CAUSE HARMFUL INTERFERENCE, AND
- (2) THIS DEVICE MUST ACCEPT ANY INTERFERENCE RECEIVED, INCLUDING INTERFERENCE THAT MAY CAUSE UNDESIRED OPERATION.

For Canada

CAN ICES-3(B)/NMB-3(B)

For Australia



For Argentina

Información acerca de la eliminación de equipos eléctricos y electrónicos al final de la vida útil (aplicable a los países que hayan adoptado sistemas independientes de recogida de residuos)



Los productos con el símbolo de un contenedor con ruedas tachado no podrán ser desechados como residuos domésticos.

Los equipos eléctricos y electrónicos al final de la vida útil, deberán ser reciclados en instalaciones que puedan dar el tratamiento adecuado a estos productos y a sus subproductos residuales correspondientes. Póngase en contacto con su administración local para obtener información sobre el punto de recogida más cercano. Un tratamiento correcto del reciclaje y la eliminación de residuos ayuda a conservar los recursos y evita al mismo tiempo efectos perjudiciales en la salud y el medio ambiente.



Declaration of Conformity with regard to the EMC Directive 2014/30/UE

Declaration of Conformity with regard to the RoHS Directive 2011/65/EU

Manufacturer:

JVCKENWOOD Corporation
3-12, Moriyacho, Kanagawa-ku, Yokohama-shi, Kanagawa
221-0022, JAPAN

EU Representative:

JVCKENWOOD Europe B.V.
Amsterdamseweg 37, 1422 AC UITHOORN, THE
NETHERLANDS

Déclaration de conformité se rapportant à la directive EMC 2014/30/UE

Déclaration de conformité se rapportant à la directive RoHS 2011/65/UE

Fabricant:

JVCKENWOOD Corporation
3-12, Moriyacho, Kanagawa-ku, Yokohama-shi, Kanagawa
221-0022, JAPON

Représentant dans l'UE :

JVCKENWOOD Europe B.V.
Amsterdamseweg 37, 1422 AC UITHOORN, PAYS-BAS

Konformitätserklärung in Bezug auf die EMV-Richtlinie 2014/30/UE

Konformitätserklärung in Bezug auf die RoHS-Richtlinie 2011/65/UE

Hersteller:

JVCKENWOOD Corporation
3-12, Moriyacho, Kanagawa-ku, Yokohama-shi, Kanagawa
221-0022, JAPAN

EU-Vertreter:

JVCKENWOOD Europe B.V.
Amsterdamseweg 37, 1422 AC UITHOORN, NIEDERLANDE

Conformiteitsverklaring met betrekking tot EMC-richtlijn 2014/30/EU

Conformiteitsverklaring met betrekking tot RoHS-richtlijn 2011/65/EU

Fabrikant:

JVCKENWOOD Corporation
3-12, Moriyacho, Kanagawa-ku, Yokohama-shi, Kanagawa
221-0022, JAPAN

EU-vertegenwoordiger:

JVCKENWOOD Europa B.V.
Amsterdamseweg 37, 1422 AC UITHOORN, NEDERLAND

Dichiarazione di conformità relativa alla direttiva EMC 2014/30/UE

Dichiarazione di conformità relativa alla direttiva RoHS 2011/65/UE

Produttore:

JVCKENWOOD Corporation
3-12, Moriyacho, Kanagawa-ku, Yokohama-shi, Kanagawa
221-0022, JAPAN

Rappresentante UE:

JVCKENWOOD Europe B.V.
Amsterdamseweg 37, 1422 AC UITHOORN, PAESI BASSI

Declaración de conformidad con respecto a la Directiva EMC 2014/30/UE

Declaración de conformidad con respecto a la Directiva RoHS 2011/65/UE

Fabricante:

JVCKENWOOD Corporation
3-12, Moriyacho, Kanagawa-ku, Yokohama-shi, Kanagawa
221-0022, JAPAN

Representante en la UE:

JVCKENWOOD Europe B.V.
Amsterdamseweg 37, 1422 AC UITHOORN, PAÍSES BAJOS

Declaração de Conformidade relativa à Diretiva EMC 2014/30/UE

Declaração de conformidade relativa à Diretiva RoHS 2011/65/UE

Fabricante:

JVCKENWOOD Corporation
3-12, Moriyacho, Kanagawa-ku, Yokohama-shi, Kanagawa
221-0022, JAPÃO

Representante na UE:

JVCKENWOOD Europe B.V.
Amsterdamseweg 37, 1422 AC UITHOORN, PAÍSES BAIXOS

Before Use/ Installation Procedure

WARNING

To prevent injury or fire, take the following precautions:

- To prevent a short circuit, never put or leave any metallic objects (such as coins or metal tools) inside the unit.
- Installation and wiring of this product require specialist skill and experience. To assure your safety, please request a specialist technician to install the unit.
- When you make a hole to install the camera, check the location of pipes, tanks and wiring and avoid touching them. Otherwise it may cause the fire.
- When you make a hole with a drill, use goggles to protect your eyes.

CAUTION

To prevent damage to the product, take the following precautions:

- Make sure to ground the unit to a negative 12V/24V DC power supply.
- When replacing a fuse, only use a new fuse with the prescribed rating. Using a fuse with the wrong rating may cause your unit to malfunction.
- Do not use your own screws. Use only the screws provided. If you use the wrong screws, you could damage the unit.

NOTE

- This product is a camera that provides mirror images (left and right inverted).
- The TV can be connected to an RCA video input that is compatible with the HD camera picture quality, but please check whether the TV you use has a reverse gear activation function.
- This product is designed to supplement the driver's rear view, but the camera images do not show all dangers and obstacles. Be sure to look behind you when reversing to confirm the view.
- This product features a wide-angle lens, so the near view is wide and the far view is narrow, which may create a false sense of distance. Be sure to look behind you when reversing to confirm the view.
- Do not wash your car with an automatic car wash or high-pressure water as it may result in water entering the camera or the camera falling off.
- Check camera bracket installation before driving.
 - Are the screws loose?
 - Is the camera bracket firmly secured?
 - If the rear view camera comes loose while you are driving it may cause an accident.

- Before finally installing the unit, connect the wiring temporarily, making sure it is all connected up properly, and the unit and the system work.
- When mounting this unit, make sure none of the leads are trapped between this unit and the surrounding metalwork or fittings.
- Do not mount this unit near the heater outlet, where it would be affected by heat, or near the doors, where rainwater might splash onto it. (Never install in locations such as the above because of the danger of malfunction due to high temperatures.)
- Before drilling any mounting holes always check behind where you want to drill the holes. Do not drill into the gas line, brake line, electrical wiring or other important parts.
- If this unit is installed in the passenger compartment, anchor it securely so it does not break free while the car is moving, and cause injury or an accident.
- If this unit is installed under a front seat, make sure it does not obstruct seat movement. Route all leads and cords carefully around the sliding mechanism so they do not get caught or pinched in the mechanism and cause a short circuit.

Care and maintenance

- When the product gets dirty, wipe dry with a silicon cloth or soft cloth. If it is seriously stained, remove stain with a cloth moistened with a neutral cleaner and then wipe the cleaner away. Do not use a hard cloth and/or a volatile substance such as lacquer thinner or alcohol, scratches, deformation, degradation and/or damage may result.
- When a lens component gets dirty, wipe gently with a soft cloth moistened with water. Do not rub with a dry cloth to prevent scratching the lens.

Installation Procedure

This section is for the professional installer. For safety's sake, leave wiring and mounting to professionals. Consult the car audio dealer.

- 1** To prevent a short circuit, remove the key from the ignition and disconnect the ⊖ battery.
- 2** Make the proper input and output wire connections for each unit.
- 3** Connect the wiring harness wires in the following order: ground, ignition and camera unit.
- 4** Install the unit in your car.
- 5** Reconnect the ⊖ battery.

⚠WARNING





- If you connect the ignition wire (Red) to the car chassis (Ground), you may cause a short circuit, that in turn may start a fire. Always connect those wires to the power source running through the fuse box.
- Do not cut out the fuse from the ignition wire (Red). The power supply must be connected to the wires via the fuse.

⚠CAUTION

- If your car's ignition does not have an ACC position, connect the ignition wires to a power source that can be turned on and off with the ignition key. If you connect the ignition wire to a power source with a constant voltage supply, as with battery wires, the battery may die.
- If the fuse blows, first make sure the wires aren't touching to cause a short circuit, then replace the old fuse with one with the same rating.
- Insulate unconnected wires with vinyl tape or other similar material. To prevent a short circuit, do not remove the caps on the ends of the unconnected wires or the terminals.
- After the unit is installed, check whether the brake lamps, blinkers, wipers, etc. on the car are working properly.
- Install so that it does not obstruct the rear field of view.
- Install so that it does not protrude from the side of the car.
- Do not perform installation in rain or fog.
- When humidity is high, dry the surface to which the unit is to be attached before installing.
- Moisture on the attachment surface reduces adhesive strength, which may lead to the unit coming off.
- Do not attach the camera bracket to areas on the car body treated with fluorocarbon resin, or glass.
- May result in the rear view camera falling off.
 - Do not apply water to the unit.
 - Do not expose the unit to rain.
 - Do not subject the camera to unnecessary force.
 - Thoroughly clean where tape is used for sticking on the unit.
- Refer to the Instruction's manual for details on connecting the other units, then make connections correctly.
- Secure the wiring with cable clamps or adhesive tape. To protect the wiring, wrap adhesive tape around them where they lie against metal parts.
- Route and secure all wiring so it cannot touch any moving parts, such as the gear shift, handbrake and seat rails.

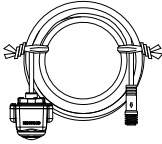
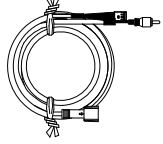
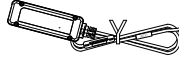
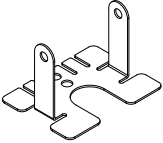
- Do not route wiring in places that get hot, such as near the heater outlet. If the insulation of the wiring melts or gets torn, there is a danger of the wiring short-circuiting to the vehicle body.
- When replacing the fuse, be sure to use only fuse of the rating prescribed on the fuse holder.
- To minimize noise locate the TV antenna cable, radio antenna cable and RCA cable as far away from each other as possible.
- Lay the cords by avoiding high-temperature areas. Use corrugated tubes for wiring inside the engine room. If a cord contacts a high-temperature area of the vehicle, the coating may melt and cause short-circuiting, which may lead to a fire or electric shock hazard.

Accessories

Camera (3.0 m).....1 	Power cord (6.0 m ^[1]).....1 
Power unit.....1 	Camera bracket.....1 
Screw (M3 × 5 mm).....2 	Camera bracket clamping screw (Ø3 × 8 mm).....1 
Grommet.....1 	Band.....1 

[1] Including the power unit

Installation

Recommended Installation Position

Examples of correct camera installation on the rear of the vehicle

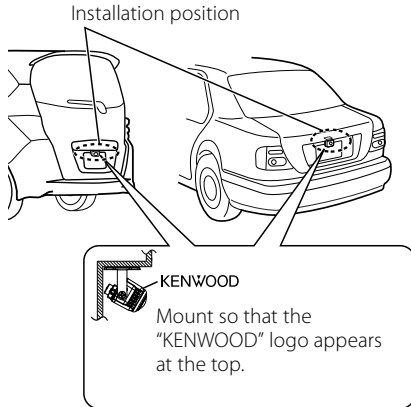

Installing the Camera/Adjusting its angle

- 1 Decide the camera installation position.
- 2 Clean the camera installation surface.
Using a commercially available cleaner, wipe dirt, moisture and oil away from the surface on which the camera bracket is to be attached.
- 3 If required, separate the camera bracket from the camera and adjust the shape according to the surface on which it will be attached.

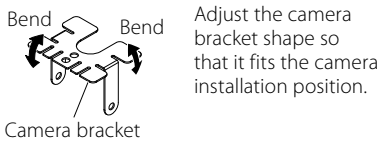

- 4 Mount the camera on the camera bracket.
Secure the camera to the camera bracket with the mounting screw. (2 locations on each side)
Mount so that the "KENWOOD" logo appears at the top.

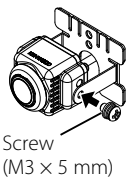

The camera has two securing holes at the side at the top and bottom.
Please adjust according to the installation.

Installation example

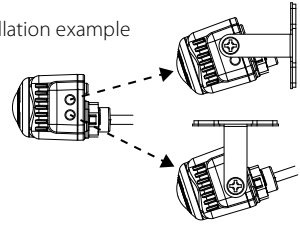

- 5 Fix the camera temporarily with tape, etc. Using a piece of tape, etc., fix the camera temporarily.

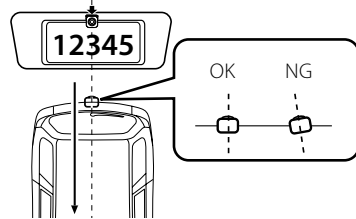

Install the camera at the center of the vehicle and not to hide the number plate. And also install straight toward the forward/reverse direction of the vehicle. Be careful not to lean the camera toward other directions of the vehicle, etc.

- 6 Complete all of the required connections.
- 7 Display the camera video.
Before viewing the camera, apply the parking brake and chock the wheels so that the vehicle will not move. Otherwise, an unexpected accident may result.
For displaying the camera video, read the instruction manual for your video monitor.
Change the shift lever to the R (Reverse) range to view the image of the rear of the vehicle.
- 8 Adjust the camera angle.
When adjusting the camera angle, be careful not to stretch the camera cord.
Adjust the angle so that the rear of the vehicle or the bumper can be seen at the bottom of the monitor.

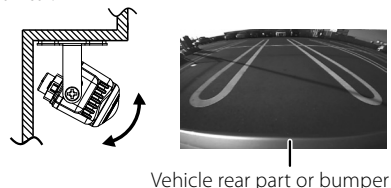

9 After adjusting the camera angle, tighten the retaining screws firmly.

Inspect the retaining screws at times. If they are loose, tighten them firmly.

10 Fix the camera firmly in position.

Peel off the paper liner from the double-side adhesive tape on the camera bracket and attach it. After attaching, push the camera bracket with your finger to ensure close adhesion.

Do not touch the adhesive surface with your hand or peel and reattach an attached tape, as these will degrade the adhesive force and may cause the camera bracket to be detached. If required, secure the bracket on the vehicle body using the camera bracket clamping screw. The camera bracket has two holes for the screw. Select one of them to fit the position of the attachment.

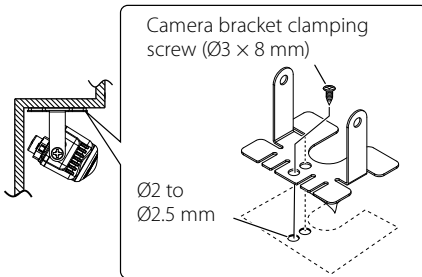

Using a grommet

⚠CAUTION

- When drilling a hole in the car body to mount the camera, check the positions of fluid lines, tanks, electrical wiring, etc. to make sure there will be interference or contact with these. Failure to do so could result in a fire, electric shock or malfunction.
- If drilling work is required, be sure to wear a pair of goggles to prevent chips and debris from entering your eyes. Otherwise, there is a risk of injuries.

1 Drill a hole of $\Phi 13$ mm for the wiring.

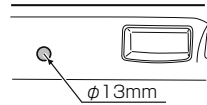

2 Make a notch in the enclosed grommet and pass the cable connector on the camera side through it.

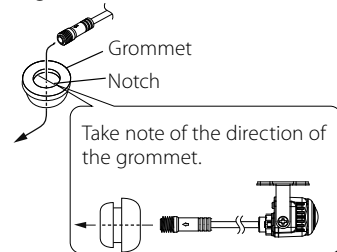

3 Waterproof the grommet area on the inner side of the back door with a commercially available sealant or similar.

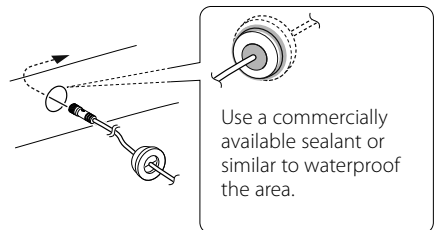

Connections

⚠ CAUTION

- If the engine key of your vehicle does not have the ACC position, branch the wire energized when the engine key is ON and connect it to the accessory power cord.
- Before proceeding to connections, make sure that the engine key is not inserted and disconnect the (⊖) terminal of the battery to prevent the short-circuiting incident.
- Do not bend the camera cord to a diameter of 40 mm or a radius of 20 mm or less.

Basic Connections

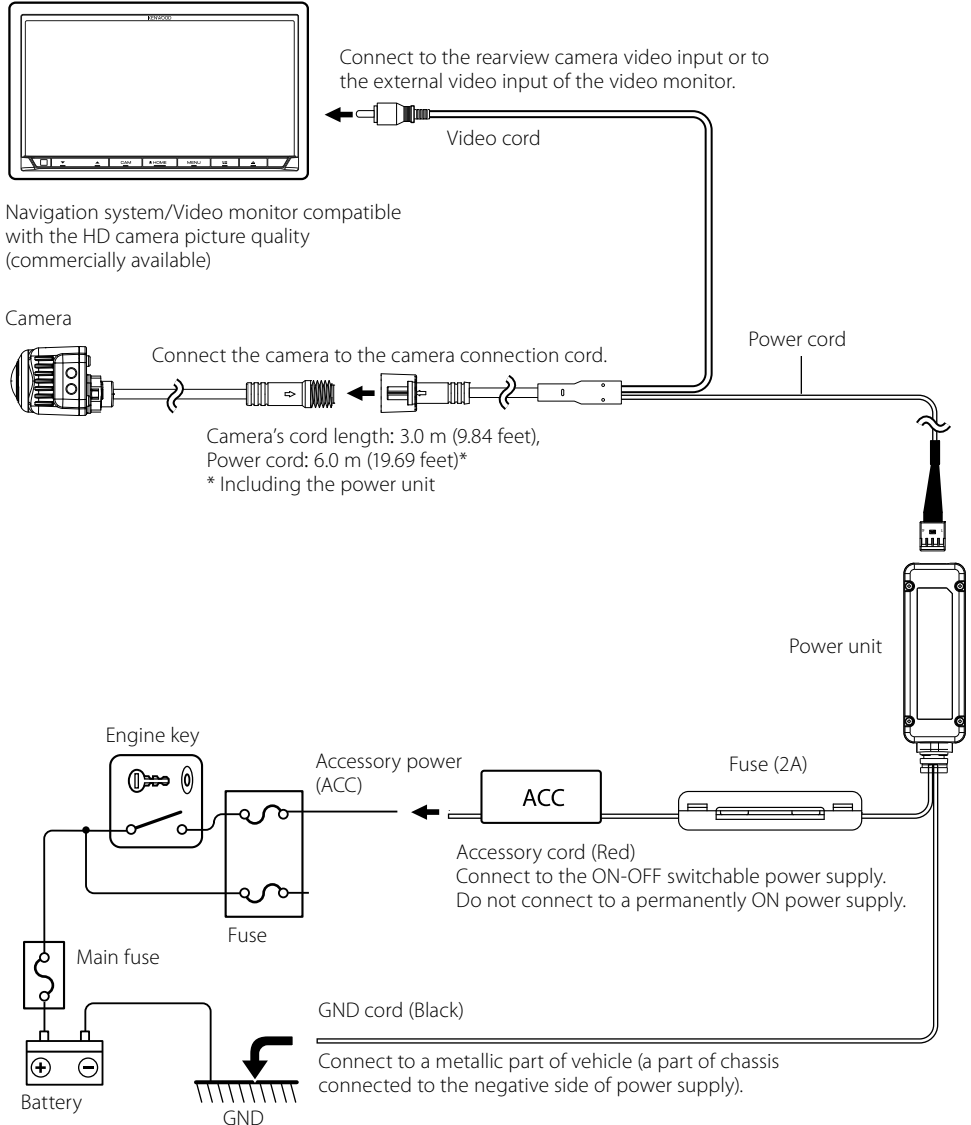

Specifications

Camera Unit

Lens

Wide angle,
Focal length: 1.86 mm,
F value 2.0

Angles of view

: Horizontal: 180°
: Vertical: 103°

Waterproof and dustproof: IP67

Image sensor: 1/3.8-inch color CMOS sensor

Number of pixels

: 1.3 Mega pixels

Object illuminance

: 1.0 lux to 100 k lux

Resolution: 1280 × 720

Frame rate: 30 fps

Video Output

: Wide-angle mirror image (for rearview)

Output I/F: HD-TVI

Operating temperature

: -30 °C to +85 °C

Dimensions (W × H × D)

: 31.1 × 23.0 × 25.2 mm
1-1/4 × 7/8 × 1 inch

Weight

: 33.2 g (1.2 oz)
(without cable)

Power unit

Operating voltage: DC 12V/24V

Dimensions (W × H × D)

: 69.2 × 23.6 × 15.5 mm
2-3/4 × 15/16 × 5/8 inch
(Excluding protrusions)

- Mirror image means that the video image inverts the left and right just like the image seen on the rearview mirror or a side mirror.
- Specifications subject to change without notice.

Information on Disposal of Old Electrical and Electronic Equipment (applicable for countries that have adopted separate waste collection systems)



Products with the symbol (crossed-out wheeled bin) cannot be disposed as household waste.

Old electrical and electronic equipment should be recycled at a facility capable of handling these items and their waste byproducts.

Contact your local authority for details in locating a recycle facility nearest to you. Proper recycling and waste disposal will help conserve resources whilst preventing detrimental effects on our health and the environment.

KENWOOD Warranty Card

Убедитесь в правильном написании серийного номера/ Seriennummer überprüfen/ Vérifier si le numéro de série est inscrit/ Comprobar si el número de serie está correctamente escrito/ Comprobar si el número de serie está correctamente escrito/ Certificar-se que o número de série está escrito corretamente/ Ελέγξτε εάν αναγράφεται ο Αριθμός σειράς/ Controleer het serienummer, of deze correspondeert met het toestel./ Tjek om serie nummer er noteret./ Tarkista että sarjanumero kirjoiteltu/ Kontroler om serienummer er noteret./ Athugid hvort serial number er a taekinu./ Kontrolera om serienummer är noterat./ Ara li s-'serial number' ikun imnizel sew./ Check whether S/No. is written!

Наименование модели и серийный номер/ Identification du produit/ Geräte-Typ und Seriennummer/ Identification du produit/ Produkt navn og serie nummer/ Modelo y Número de serie/ Malli ja sarjanumero/ Μοντέλο και αριθμός σειράς/ Modello e numero di matricola/ Modell og serienummer/ Modelo e numero de série/ Apparat typ & serienummer/ Identificatie van het produkt/ Mólél heiti og raðnúmer/ Il-Mudell u s-serial number/ Model number & serial number

Название, адрес и штамп дилера/ Revendeur & cachet/ Stempel und Unterschrift des Händlers/ Revendeur & cachet/ Forhandler/ Distribuidor y sello/ Jälleenmyyjä & leima/ Σφραγίδα εταιρίας/ Timbro del rivenditore/ Forhandlerens navn og stempel/ Agente e carimbo/ Återförsäljare & stämpel/ Dealer & stempel/ Undirritun og stimpill söluáðila/ Timbru tal-bejjiagh/ Dealer & stamp

Дата покупки/ Date d'achat/ Kaufdatum/ Date d'achat/ Købsdato/ Fecha de compra/ Ostopäivä/ Ημερομηνία αγοράς/ Data di acquisto/ Kjøpt dato/ Data de compra/ Inköpsdatum/ Aankoopdatum/ Sölu dagur/ Id-data ta' meta nxtara/ Purchase date

Фамилия и адрес покупателя/ Nom & adresse du client/ Name und Anschrift des Käufers/ Nom & adresse du client/ Købers navn og adresse/ Nombre y dirección del cliente/ Asiakkaan nimi & osoite/ Ονομα και διεύθυνση αγοραστή/ Nome e indirizzo del cliente/ Kundens navn og adresse/ Nome e morada do comprador/ Kundens navn & adress/ Naam & adres van de klant/Nafn og heimilisfang kaupanda/ L-isem u l-indirizz tax-xerrej/ Name & address of customer

Suomi

JVCKENWOOD Europe B.V.

KENWOOD-tuotteiden käyttäjälle:

Kiitos siitä, että päätit ostaa tämän KENWOODin tuotteen (jäljempänä "tuote"). Jos tuote osoittautuu vialliseksi normaaleissa käyttöolosuhteissa, se korjataan tai vaihdetaan ilmaiseksi tämän tuotetakuukortin ehtojen mukaisesti. Jos tuote on ostettu jossain EU:n jäsenmaassa ja siihen ilmaantuu vika, käänny keneri tahansa KENWOOD-tuotteiden virallisen maahantuojan, tunnustetun jälleenmyyjän, hyväksytyen huoltokeskuksen tai EU:n alueella toimivan, KENWOOD-tuotteita myyvän vähittäismyyjän puoleen. Esitä samalla ostokuitti tai muu riittävä todiste, josta käy ilmi ostoaikakohta. Jos tuote on ostettu EU:n ulkopuolelta, se täytyy toimittaa takaisin tuotteen myyneelle vähittäismyyjälle.

Jos tuotteesi on ostettu EU:n alueella ja haluat saada selvillä lähimmän tunnustetun EU:n sisällä toimivan jälleenmyyjän yhteystiedot, voit ottaa yhteyttä alla olevaan toimipisteeseemme:

JVCKENWOOD Europe B.V.
Amsterdamseweg 37, 1422 AC Uithoorn
The Netherlands
+31 (0) 297 - 519 900
www.kenwood.eu

Säilytä tämä tuotetakuukortti, sillä tarvitset sitä korvausvaatimustapauksissa.

Tuotetakuu on voimassa yhden vuoden ajan alkuperäisestä ostopäivästä lähtien, jos tuote on ostettu KENWOOD-tuotteiden vähittäismyyjältä. Tuotetakuu kattaa sekä materiaali- että valmistusvirheet, ja ne korjataan ilmaiseksi. Pidätämme itsellämme oikeuden vaihtaa tuotteen uuteen, jos viallista tuotetta ei pystytä korjaamaan järkevin kustannuksin. Pakkaus-, asennus- ja muut korjaustoihin epäsuorasti liittyvät kustannukset ja muut epäsuorat riskit eivät kuulu tuotetakuun piiriin, vaan niistä veloitetaan erikseen.

2. Sopimusehdot

A. Kaikkiin tämän tuotetakuun perusteella tehtyihin korvausvaateisiin

on liitettävä tämä tuotetakuukortti sekä myös

- Ostajan koko nimi ja osoite
- EU:n alueella toimivan vähittäismyyjän laatima ostokuitti tai muu ostopäivän osoittava asiakirja
- Sen vähittäismyyjän koko nimi ja osoite, jolta tuote on ostettu
- Tuotteen sarjanumero ja malli

Jos näitä tietoja ei pystytä toimittamaan tai jos tuotetta on mitenkään muunneltu tai modifioitu ostoaikankohdan jälkeen, KENWOOD yhtiöllä on oikeus kieltäytyä korjaamasta tuotetta tämän tuotetakuun ehtojen mukaisesti.

B. Tuote on valmistettu siten, että se täyttää kaikki ne kansalliset tai paikalliset normit ja turvallisuusvaatimukset, jolta sovelletaan Euroopassa toimivan valmistajan kotimaassa, jossa tuote ensimmäisen kerran myytiin. EU:n ulkopuolisen käytön vaatimat muutokset eivät kuulu tämän tuotetakuun piiriin eikä KENWOOD vastaa mistään tällaisista muutokorjausjaukoiluista eikä niiden yhteydessä aiheutuneista vahingoista.

Jos tuotetta käytetään sellaisessa eurooppalaisessa maassa, jossa sovelletaan eri normeja ja vaatimuksia kuin Euroopassa toimivan valmistajan kotimaassa, tuotetakuun tarjoamia huoltopalveluja ei voi hyödyntää ellei ostaja omalla kustannuksellaan modifioi tuotetta vastaamaan kotimaassaan sovellettuja normeja ja vaatimuksia. Käyttäjä on lisäksi velvollinen maksamaan kaikki kuljetuskustannukset alkuperäiseen ostomaahan ja sieltä takaisin sellaisissa tapauksissa, joissa huoltoon tuotava tuote poikkeaa kyseisessä maassa toimivan virallisen maahantuojan markkinoimista tuotteista eikä asianmukaisia varaosia ole saatavilla tässä maassa tai jos huoltoonmenpiteitä ei voida suorittaa kyseisessä maassa jostain muusta hyväksyttävästä syystä johtuen.

C. Tämä tuotetakuu ei kata seuraavia tapauksia:

- tuotteelle suoritetuista muunnostöistä eikä tavanomaisista ylläpitoa ja säätämistä, mukaan lukien tuotteen käsikirjassa mainitut jaksottaiset tarkastukset.
- riittämättömistä ja asiaankuulumattomista korjauksista

aiheutuneita vaurioita, jotka on suorittanut kuka tahansa sellainen henkilö tai yhteisö, jota KENWOOD ei ole hyväksynyt tuotetakuukorjauksien suorittajaksi

(c) tuotteelle aiheutuneita vaurioita, jotka johtuvat huolimattomuudesta, onnettomuuksista, muunnoksista, vääränlaisesta asennuksesta tai pakkaustavasta, väärinkäytöstä ja vääränlaisien varaosien käytöstä

(d) tuotteelle tulipalosta, veteen upottamisesta, salamaniskusta, maanjäristyksestä, riittämättömästä ilmastoinnista, force majeure -tapahtumista, minkälaisesta tahansa väärästä sähköverkkoon kytkemisestä ja mistä muusta tahansa KENWOODin vaikutuspiiriin ulkopuolella olevasta tapahtumasta aiheutuneita vaurioita

(e) käyttämille laitteiden teknisten erittelyjen ohjearvot ylittävistä, liian voimakkaista äänitasoista aiheutuvia vaurioita tai minkä tahansa tyypisiä vaurioita, joita on aiheutunut äänilevyille, ääninauhille, kasettinauhille, videonauhille, CD-levyille tai mille muille tahansa laitteille, jotka eivät ole tuotteeseen kuuluvia osia.

(f) kuluvia tai kuluneita tuotteen osia, jotka on vaihdettava osana normaalia huoltoa. Kyseiset osat sisältävät ainakin seuraavat komponentit (mutteivät välttämättä rajoitu vain niihin): äänikasetit, äänirasian neulat, käyttöohjain, äänipäät, telineet, kuivaparistot, laddattavat paristot ja pääteputket.

(g) tuotetta, joista on poistettu, muutettu tai turmeltu osa sarjanumeroista tai kaikki sarjanumerot.

3. Tämä tuotetakuu koskee kaikkia ostajia, jotka ovat laillisesti hankineet kyseisen tuotteen.

Jos yllämainitut ehdot täyttyvät, tuote korjataan tai vaihdetaan ilmaiseksi. Nämä oikeudet eivät mitenkään poista tai vaikuta tuotteen käyttäjällä asiaan kuuluvien lakisäädösten perusteella oleviin muihin oikeuksiin.

HUOM.

Tämä takuukortti ja kuitti tai lasku on esitettävä ennen varastetun tai vahingoittuneen etupaneelin hankintaa.

Nederland **JVCKENWOOD Europe B.V.** **PRATIJK**

Geachte gebruiker van KENWOOD producten, Wij danken U voor het kiezen van dit KENWOOD product ("het Product"). Indien het Product, bij normaal gebruik, gebreken zou vertonen, zal het gratis worden hersteld of vervangen overeenkomstig de bepalingen van deze Garantiekaart. Indien het product aangekoht werd in een EEG lidstaat en U bij het gebruik ervan problemen ondervindt, gelieve het dan aan te bieden bij een officiële KENWOOD importeur, Erkend Verdelers, Erkend Service Center of detailhandelaar voor KENWOOD producten in de EEG, tesamen met het aankoopbewijs of elk ander document dat de datum van aankoop van het Product bevestigt. Indien het Product werd aangekoht buiten de EEG moet het aangeboden worden aan de verkoper bij wie het Product gekoht werd. Indien het product aangekoht werd in de EEG en U de coördinaten van de dichtbijzijnde Erkende Verdelers in de EEG wenst te vernemen, gelieve dan contact op te nemen met:

JVCKENWOOD Europe B.V.
Amsterdamseweg 37, 1422 AC Uithoorn
Tel. 0257-519900
www.kenwood.nl

U dient deze Garantiekaart zorgvuldig bij te houden aangezien zij noodzakelijk is om Uw aanspraken op deze Garantie te doen gelden.

De garantie voor het Product is geldig gedurende één jaar vanaf de datum van de oorspronkelijke aankoop bij een detailhandelaar van KENWOOD producten. De garantie slaat zowel op de nodige wisselstukken als de werken, en de herstellingen zullen gratis gebauren. Wij reserveren ons recht het Product te vervangen indien het herstellen ervan niet economisch verantwoord is. Verpakking-, installatie- of andere kosten of risico's onrechtstreeks verbonden aan de eigenlijke herstelling, zijn niet inbegrepen in de garantie en zullen aangerekend worden.

- Garantievoorwaarden
- Elke aanspraak op deze garantie moet vergezeld zijn van deze Garantiekaart en dient daarenboven te vermelden:
 - Uw volledige naam en adres.
 - Het aankoopbewijs of elk ander document waarop de datum van aankoop bij een detailhandelaar gevestigd in Europa

- vermeld is.
- De volledige naam en het adres van de detailhandelaar bij wie het Product werd aangekoht.
- Het serieummer en de naam van het model van het Product. Indien deze informatie niet kan worden meegedeeld, of indien het Product op enigerlei wijze sinds de datum van de aankoop werd gewijzigd, behoudt KENWOOD Corporation zich het recht voor te weigeren het toestel te herstellen onder de voorwaarden van deze Garantie.
- Het Product werd vervaardigd in overeenstemming met alle nationale of lokale normen en veiligheidsvoorschriften die van toepassing zijn in het Europees land waar de fabrikant het oorspronkelijk verkocht heeft. De aanpassingen die noodzakelijk zijn voor het gebruik op een andere plaats vallen niet onder deze Garantie, en de fabrikant is niet aansprakelijk voor herstellingen die noodzakelijk zijn naar aanleiding van dergelijke aanpassingen of voor schade aan het Product die daaruit voortvloeit.

Indien het Product gebruikt wordt in een Europees land waar het onderworpen is aan standaarden en voorschriften die verschillend zijn van degeene van toepassing in het land van de oorspronkelijke verkoop door de fabrikant in Europa, dan zal het verlenen van prestaties onder deze Garantie onderworpen zijn aan de voorwaarde dat de gebruiker de kosten draagt voor de aanpassing van het Product aan de toepasselijke normen en voorschriften. Indien het Product van een verschillend type is dan deze die door de officiële inleverder op de markt worden gebracht in het land waar het product te reparatie onder deze Garantie wordt aangeboden, en de nodige wisselstukken niet in dat land voorhanden zijn, of de reparatie om een andere rechtmatige reden niet in dat land kan worden uitgevoerd, dan zal de gebruiker daarenboven de kosten dienen te dragen van het vervoer van het Product van en naar het land van de oorspronkelijke aankoop. Deze Garantie strekt zich niet uit tot:

- wijzigingen aan het Product, en het gewone onderhoud en aanpassingen, hierinbegrepen het periodiek nazicht welk voorzien is in de Gebruiksaanwijzing geleverd met het Product;
- schade veroorzaakt aan het Product door onaangepaste of verkeerd uitgevoerde herstellingen door een entiteit of persoon die niet door de fabrikant werd erkend om

- garantieherstellingen voor zijn rekening uit te voeren; schade veroorzaakt aan het Product door onachtzaamheid, ongeval, wijzigingen, gebrekkige installatie of verpakking, verkeerd gebruik of gebruik van onaangepaste wisselstukken;
- schade veroorzaakt aan het Product door brand, onderdompeling in water, blikseminslag, aardbeving, onaangepaste ventilatie, oververmact, onaangepaste stroomsterkte om welke reden ook of elke andere oorzak waarover KENWOOD geen controle heeft;
- schade aan luidsprekers tengevolge van het aanwenden van onaangepast vermogen, en schade aan platen, banden, audiocassettes, videocassettes, compact discs, of elk ander voorwerp dat niet het Product zelf is, en dit ongeacht de oorzak;
- verbruiksproducten of onderdelen waarvan vervanging nodig is ten gevolge van slijtage bij normaal gebruik, met inbegrip van (maar niet beperkt tot) wisselbare grammofon-elementen, grammofonstaalden, aandrijfriemen, lees- en opnamekoppen, racks, batterijen, oplaadbare batterijen en accu's;
- het Product waarvan de serieummers geheel of gedeeltelijk werden verwijderd, gewijzigd of uitgewist.

Deze Garantie wordt gegeven aan alle personen die op rechtmatige wijze het Product verkregen hebben.

Onder de hierboven vermelde voorwaarden zal het Product gratis worden gerepareerd onder deze Garantie wordt aangeboden, met andere rechten die de gebruiker van het Product kan putten uit andere toepasselijke wettelijke normen, en lastzede ook niet aan.

OPGELET
Deze kaart en aankoopnota zijn vereist om een nieuw afneembaar front paneel te bestellen, in het geval van diefstal of beschadiging.

UK & Ireland **JVCKENWOOD U.K. Limited** **WAVL**

Dear User of KENWOOD Products: Thank you for having chosen this KENWOOD product (the "Product"). If it becomes defective under normal operating conditions, it will be repaired or replaced free of charge in conformity with the terms of this Warranty Card. In the event that the Product was purchased in any EEC Member State and you experience a problem, please take the Product to any official KENWOOD importer, Authorized Dealer, Authorized Service Centre or retailer of KENWOOD products in the EEC, together with the purchase receipt or other adequate proof of the date of purchase. If it was purchased outside the EEC, the product must be taken to the retailer from whom it was purchased. If the Product was purchased in the EEC and you wish to know the location of your nearest Authorized Dealer in the EEC, please contact the following for information.

JVCKENWOOD U.K. Limited
12 Priestley Way, London, NW2 7BA
Email: Enquiries@uk.kenwood.com
www.kenwood-electronics.co.uk

Please keep this Warranty Card as you will need it should a claim be necessary.

The Product is guaranteed for one year from the date of original purchase from any retailer of KENWOOD products. The guarantee covers both materials and workmanship, and the repair shall be carried out free of charge. We reserve the right to replace the Product if it cannot be repaired economically. Packaging, installation costs and any other costs or risks indirectly related to the actual repair, are not included in the warranty services and will be charged.

- Conditions
- Any claim under this warranty must be accompanied by this Warranty Card, and in addition:
 - Your full name and address.
 - The receipt or other document showing the date of purchase from a retailer established in Europe.
 - The full name and address of the retailer from whom the Product was purchased.

- The Serial Number and Model name of the Product. If information cannot be provided, or if the Product has been modified or altered in any way since the date of purchase, JVC KENWOOD Corporation reserves the right to refuse to repair the Product under the terms of this Warranty.
 - The Product has been manufactured so that it complies with all national or local standards and safety requirements applicable in the country of first sale by the manufacturer in Europe. Modifications necessary for use elsewhere are not covered by this Warranty, and no liability for repair will be accepted in respect of any work done in this connection, or any damage to the Product arising from such work.
- If the Product is used in a European country where it is subject to other standards and requirements than those applicable in the country of first sale by the manufacturer in Europe, then any warranty services will be subject to the condition that the user bear the cost of adapting the Product to the applicable standards and requirements. In addition, if the Product is different in type from those marketed by the official importer in the country where it is offered for warranty repair, and the appropriate spare parts are unavailable in this country or the warranty service cannot be provided in this country for another legitimate reason, then the cost of shipping the Product for repair to and from the country of original purchase shall be borne by the user.
- C. This Warranty does not cover:

- alterations of the Product, and normal maintenance and adjustments, including periodic check-ups mentioned in the Manual used with the Product;
- damage to the Product caused by inadequate or improper repairs carried out by any person or entity which is not authorized by the manufacturer to perform warranty services on its behalf;
- damage to the Product caused by negligence, accidents, modifications, defective installation or packaging, misuse, and use of inappropriate spare parts;
- damage to the Product caused by fire, immersion in water, lightning, earthquake, inadequate ventilation, Acts of God, incorrect application of main voltage however arising, or any other cause beyond the control of KENWOOD;

- loudspeakers damaged by application of power levels beyond the rated specification, and damages caused for whatever reason to records, tapes, cassette tapes, video tapes, compact disks, or any other goods which are not the Product itself;
- consumable or wearing items requiring replacement as part of normal service, including (but not limited to) phonocassettes, stylus, drive belts, tape heads, racks, dry cells, rechargeable batteries and final tubes;
- the Product from which any or all of the serial numbers has been removed, modified or defaced;

This Warranty is available to any person who has legally obtained the Product.

Subject as mentioned above, the Product will be repaired or replaced free of charge. These rights in no way interfere with or otherwise affect the rights of the user of the Product under the applicable legal provisions.

ATTENTION
This card and receipt (or invoice) are necessary to purchase a new panel in case of theft or damage.

Portugal **JVCKENWOOD EUROPE B.V. Sucursal en España**

Caro utilizador dos produtos KENWOOD: Obrigado por ter escolhido este produto KENWOOD (abaixo simplesmente designado por "Produto"). Se, em condições normais de funcionamento, se verificar alguma avaria no aparelho, ele será reparado ou substituído gratuitamente em conformidade com os termos deste Cartão de Garantia. No caso de o Produto ter sido adquirido em qualquer Estado Membro da CEE e de vir a ter algum problema de funcionamento, por favor leve o Produto a um Importador Oficial KENWOOD, Vendedor Oficial, Centro de Serviços Autorizado ou revendedor de produtos KENWOOD na CEE, acompanhado do recibo de compra ou de outra prova adequada da data da sua aquisição. Se tiver sido adquirido fora da CEE, o Produto deve ser levado ao revendedor onde foi comprado. Se o Produto foi adquirido na CEE e se desejar saber onde pode encontrar o Vendedor Autorizado mais próximo, por favor contacte:

JVCKENWOOD EUROPE B.V. Sucursal en España
Tel. +351-916160808
+351-212898147
www.kenwood.pt
email: hfgoncalvesda@es.jkenwood.com

Por favor, conserve este Cartão de Garantia para o caso de alguma reclamação vir a ser necessária.

O Produto tem garantia de um ano a contar da data da sua aquisição original num qualquer revendedor de produtos KENWOOD. A garantia cobre peças e mão-de-obra, e a reparação será efectuada gratuitamente. Reservamos o direito de substituir o Produto caso este não possa ser reparado de modo económico.

- Custos de embalagem, de instalação e quaisquer outros encargos ou riscos indirectamente relacionados com a eventual reparação não estão incluídos nos serviços de garantia e, como tal, terão que ser pagos pelo utilizador.
- Condições
- Qualquer reclamação abrangida por esta garantia deverá ser apresentada por este Cartão de Garantia e ainda por:
 - Nome completo e endereço.
 - Recibo ou outro documento indicando a data de aquisição

- nome revendedor estabelecido na Europa
- Nome completo e endereço do revendedor onde o Produto foi adquirido
- Número de série e nome do modelo do Produto. Se esta informação não puder ser fornecida ou se o Produto tiver sido modificado ou de algum modo alterado depois da data de aquisição, a KENWOOD Corporation reserva o direito de recusar a reparação do Produto segundo os termos desta garantia.
- O Produto foi manufacturado conforme todos os padrões nacionais ou locais e todas as regras de segurança aplicáveis no país da Europa onde foi originalmente vendido pelo produtor. Modificações necessárias para uso num país diferente dos referidos não são cobertas por esta garantia e não será aceite nenhuma responsabilidade pela reparação de danos provocados no Produto em consequência de tais modificações.

Se o Produto for usado num país europeu onde esteja submetido a outros padrões e regras diferentes dos aplicados no país onde foi originalmente vendido na Europa pelo produtor, então todos os serviços da garantia estarão sujeitos a condição de que o utilizador suporte todos os custos de adaptação do Produto aos padrões e regras aí aplicáveis. Além disso, se o Produto for de modelo diferente daqueles vendidos por importadores oficiais no país onde ele for apresentado para reparação no âmbito da garantia e se as peças sobresselentes apropriadas não estiverem disponíveis neste país ou se o serviço de garantia não puder ser realizado neste país por uma outra razão legítima, então o custo do transporte do Produto para reparação de e para o país de aquisição original deverá ser suportado pelo utilizador.

- alterações do Produto e trabalhos de manutenção ou ajustamentos normais incluindo as revisões periódicas mencionadas no Manual que acompanha o Produto;
- danos no Produto causados por reparações inadequadas ou impróprias levadas a cabo por qualquer pessoa ou entidade não autorizadas pelo fabricante para realizar os serviços de garantia;
- danos no Produto causados por negligência, acidentes, modificações, instalação ou embalagem imperfeita, má utilização ou por uso de peças sobresselentes desapropriadas;

- danos no Produto causados por fogo, imersão em água, trovoadas, tremotes de Terra, ventilação inadequada, voltagem incorrecta ou qualquer outra causa fora do controlo de KENWOOD;
- alto-falantes danificados por aplicação de níveis de intensidade sonora superiores à especificada para cada modelo, assim como a danos causados por qualquer razão em discos, fitas magnéticas, cassetes áudio ou vídeo, discos compactos ou outros bens que não constituam o próprio Produto;
- peças sujeitas a desgaste regular e cuja substituição faz parte de um serviço normal (incluindo (mas não limitado a) cabeças de gravação, agulhas, correias, pilhas secas, pilhas recarregáveis e válvulas;
- o Produto do qual algum ou todos os números de série tenham sido retirados, modificados ou desfigurados.

Esta garantia é oferecida a qualquer pessoa que tenha adquirido legalmente o Produto.

Tal como foi acima referido, o Produto será reparado ou substituído gratuitamente. **Estes direitos não interferem nem de modo algum afectam os outros direitos de utilização do Produto que são regidos pelas determinações legais aplicáveis.**

ATENÇÃO
Este cartão e um recibo (ou factura) são necessários para comprar um painel novo em caso de roubo ou dano do mesmo.

Österreich **JVCKENWOOD DEUTSCHLAND GMBH**

Sehr geehrter Kunde, wir danken Ihnen für den Kauf dieses KENWOOD-Produkts. Sollte dieses Produkt unter normalen Betriebsbedingungen Material- oder Verarbeitungsmängel aufweisen, werden wir diese in Übereinstimmung mit den nachfolgenden Garantiebestimmungen kostenlos beseitigen, bzw. das Gerät umtauschen. Falls Sie das Produkt in einem EG-Mitgliedsstaat erworben haben, können Sie das Produkt im Schadensfall dem offiziellen KENWOOD-Reparatur-, einem autorisierten Fachhändler oder einer autorisierten Service-Werkstatt in der EG, zusammen mit dem Lieferschein, der Rechnung oder einem anderen Nachweis des Kaufdatums übergeben. Bei einem außerhalb der EG gekauften Produkt wenden Sie sich bitte an den Einzelhändler, bei dem Sie das Gerät gekauft haben. Wenn das Produkt innerhalb der EG gekauft wurde und Sie die Anschrift des nächsten autorisierten Fachhändlers wissen möchten, so wenden Sie sich bitte an:

JVCKENWOOD DEUTSCHLAND GMBH
Konrad-Adenauer Allee 1-11, 61118 Bad Vilbel
Tel. +49 (0) 6101 - 4988 0
www.kenwood.de

Bitte bewahren Sie diese Garantiekarte sorgfältig auf.

KENWOOD gewährt auf dieses Gerät eine Garantie von einem Jahr ab Kaufdatum laut Rechnung oder Kaufbeleg des KENWOOD-Händlers. Diese Garantie erstreckt sich auf Material- und Verarbeitungsmängel. Wir behalten uns das Recht vor, das Produkt umzutauschen, falls eine wirtschaftliche Instandsetzung nicht mehr möglich ist. Kosten für Verpackung und Installation sowie andere Kosten und Risiken im Zusammenhang mit der eigentlichen Instandsetzung sind nicht in der Garantieleistung enthalten und werden in Rechnung gestellt.

- Bedingungen
- Zur Gültendmachung von Garantieansprüchen sind zusätzlich zur Vorlage dieser Garantiekarte folgende Angaben erforderlich:
 - Ihr Name mit vollständiger Anschrift
 - Der Kassabeleg oder die Rechnung eines in einem EG-Staat ansässigen Einzelhändlers, aus der das ursprüngliche Kaufdatum hervorgeht.

- der vollständige Name und die Anschrift des Einzelhändlers, bei dem das Produkt gekauft wurde;
- Die Seriennummer und die Modellbezeichnung des Produkts. KENWOOD behält sich das Recht vor Garantieleistungen abzulehnen, wenn die vorgenannten Informationen fehlen oder wenn seit Ersterwerb Veränderungen am Produkt vorgenommen wurden;
- Zum Zeitpunkt der Auslieferung an den Handel erfüllt dieses Produkt alle im Bestimmungsland gültigen Normen e Sicherheitsvorschriften. Erforderliche Modifikationen zum Betrieb des Gerätes in Ländern außerhalb des Bestimmungslandes fallen nicht unter die vorgenannten Garantiebestimmungen. Außerdem übernehmen wir keinerlei Haftung für Arbeiten in diesem Zusammenhang oder für Beschädigungen des Produktes, die durch solche Arbeiten entstehen.

Wird das Produkt in einem Land benutzt, für daß dieses nicht kopiert und hergestellt worden ist, dann werden Garantiearbeiten nur dann ausgeführt wenn die Kosten für Umrüstung des Gerätes auf national gültige Normen und Sicherheitsvorschriften vom Benutzer getragen werden.

Unterscheidet sich außerdem das Produkt von den durch den offiziellen Importeur vertriebenen Produkten und sollten für die Reparatur dieses Produktes Ersatzteile nicht verfügbar sein, muß der Benutzer die Kosten für Hin- u. Rücktransport des Gerätes in das Kaufland tragen. Gleiches gilt, wenn im betreffenden Land aus anderen berechtigten Gründen keine Garantieleistungen angeboten werden können.

- Veränderungen am Produkt, sowie normale Wartungs- und Justagearbeiten, einschließlich der in der Bedienungsanleitung erwähnten regelmäßigen Kontrollen;
- Schäden am Produkt, die durch mangelhafte oder nicht fachgerechte Arbeiten entstanden sind, wenn diese Arbeiten von Dritten vorgenommen wurden, die nicht zur Durchführung von Garantieleistungen im Namen des Herstellers ermächtigt sind;
- Schäden durch Nachlässigkeit, Unfälle, Änderungen, unsachgemäße Montage, mangelhafte Verpackung, Fehlbearbeitung oder Verwendung falscher Ersatzteile bei einer

- Reparatur
- Schäden durch Feuer, Wasserschaden, Blitzschlag, Erdbeben, unzureichende Belüftung, höhere Gewalt, Anschluß an falsche Netzspannung oder sonstige von KENWOOD nicht zu verantwortende Ursachen;
 - Schäden an Lautsprechern durch den Betrieb an höheren Leistungen als den angegebenen. Schäden an Schallplatten, Tonbändern, Ton- und Videokassetten, CD-Kompaktschallplatten und anderen Gegenständen, die nicht Bestandteil des Produkts sind;
 - Verbrauchs- oder Verschleißteile, die im Rahmen des normalen Kundendienstes auszutauschen sind, wie z.B.: Tonabnehmersysteme, Nadeln, Antriebsriemen, Tonköpfe, Einschübe, Tormöbel, Trockenbatterien, wiederaufladbare Akkus, Leistungs-Endröhren u.s.w.
 - Alle Produkte, bei denen die Seriennummer(n) ganz oder teilweise entfernt, verändert oder unkenntlich gemacht wurde(n).

Diese Garantie kann von allen Personen beansprucht werden, die das Produkt legal erworben haben.

In Übereinstimmung mit den vorgenannten Garantiebedingungen wird das Produkt kostenlos instandgesetzt oder umgetauscht. Dieses Recht bein-trächtigt in keiner Weise sonstige Rechte des Benutzers im Rahmen der gültigen rechtlichen Bestimmungen.

Instandsetzung oder Austausch bewirken keine Verlängerung der Garantiezeit. Weitergehende Ansprüche sind ausgeschlossen, insbesondere solche auf Wundlung, Minderung oder Schadenersatz.

ZUR BEACHTUNG
Diese Garantiekarte und der Kaufbeleg werden benötigt, um im Falle des Verlustes ein neues Bauteil zu erwerben.

This warranty will be honored only in the U.S.A.

KENWOOD LIMITED WARRANTY FOR CAR STEREO COMPONENTS

HOW LONG IS THE WARRANTY

JVCKENWOOD USA Corporation ("KENWOOD") warrants this product for a period of one (1) year from the date of original purchase.

WHAT IS COVERED AND WHAT IS NOT COVERED

Except as specified below, this warranty covers all defects in material and workmanship in KENWOOD car stereo components. The following are not covered by the warranty:

- Any product which is not distributed in the U.S.A. by KENWOOD or which is not purchased in the U.S.A. from an authorized KENWOOD car stereo dealer or an automobile dealer, unless the product is purchased through the U.S.A. Military Exchange Service.
- Any product on which the serial number has been defaced, modified or removed.
- Damage, deterioration or malfunction resulting from:
 - Any shipment of the product (claims must be presented to the carrier).
 - Installation or removal of the product.
 - Accident, acts of nature, misuse, abuse, neglect, unauthorized product modification or failure to follow instructions supplied with the product.
 - Repair or attempted repair by anyone not authorized by KENWOOD.
 - Any other cause which does not relate to a product defect.

WHO IS PROTECTED

This warranty is enforceable only by the original purchaser.

WHAT WE WILL PAY FOR

We will pay for all labor and material expenses for covered items. Payment of shipping charges is discussed in the next section of this warranty.

HOW TO OBTAIN WARRANTY SERVICE

If your KENWOOD product ever needs service:

- Take or ship it to any KENWOOD Authorized Service Center in the U.S.A. along with a complete description of the problem. (If you are uncertain as to whether a Service Center is authorized, please call **1-800-KENWOOD** for the nearest Service Center. **1-800-536-9663**.)
- Although you must pay any shipping charges if it is necessary to ship the product for warranty service, we will pay the return shipping charges if the repairs are covered by the warranty within the United States.
- Whenever your units are taken or sent for warranty service, you must include a copy of the original dated sales receipt as proof of warranty coverage.

LIMITATION OF IMPLIED WARRANTIES

ALL IMPLIED WARRANTIES, INCLUDING WARRANTIES OF MERCHANTABILITY AND FITNESS FOR A PARTICULAR PURPOSE, ARE LIMITED IN DURATION TO THE LENGTH OF THIS WARRANTY.

EXCLUSION OF DAMAGES

KENWOOD'S LIABILITY FOR ANY DEFECTIVE PRODUCT IS LIMITED TO THE REPAIR OR REPLACEMENT OF THE PRODUCT AT OUR OPTION. KENWOOD SHALL NOT BE LIABLE FOR:

- INSTALLATION OR REMOVAL CHARGES, DAMAGE TO OTHER PROPERTY CAUSED BY ANY DEFECTS IN KENWOOD CAR STEREO COMPONENTS, DAMAGES BASED UPON INCONVENIENCE, LOSS OF USE OF THE PRODUCT; OR
 - ANY OTHER DAMAGES, WHETHER INCIDENTAL, CONSEQUENTIAL OR OTHERWISE.
- SOME STATES DO NOT ALLOW LIMITATIONS ON HOW LONG AN IMPLIED WARRANTY LASTS AND/OR DO NOT ALLOW THE EXCLUSION OR LIMITATION OF INCIDENTAL OR CONSEQUENTIAL DAMAGES, SO THE ABOVE LIMITATIONS AND EXCLUSIONS MAY NOT APPLY TO YOU.

This warranty gives you specific legal rights, and you may also have other rights which vary from state to state.

If a problem develops during or after the Limited Warranty Period, or if you have any questions regarding the operation of the product, you should contact your KENWOOD Authorized Dealer or Authorized Service Center. If the problem or your question is not handled to your satisfaction, please contact our Customer Relations Department at the address listed below:

JVCKENWOOD USA Corporation
PO Box 22745, 2201 E. Dominguez St. Long Beach, CA 90810-5745
Tel: (800) 536-9663
www.us.jvckenwood.com

ATTENTION

This card and receipt (or invoice) are necessary to purchase a new panel in case of theft or damage.

Units purchased through the U.S.A. military exchange service overseas may be serviced under warranty in the continental U.S.A., subject to the following conditions.

- The original warranty is in effect.
- Proof of purchase is provided to the servicer.

WARRANTY FOR MILITARY MARKET

JVC KENWOOD corporation is proud of the quality and workmanship of its audio equipment. This unit has been properly designed, tested and inspected before it was shipped to you. If properly installed and operated in accordance with instructions furnished, it should give you an optimum reliable performance.

WARRANTY PERIOD

This product is warranted for a period of (1) year from the date of the original purchase.

SCOPE OF WARRANTY

Except as specified below, this warranty covers all defects in materials and workmanship of the KENWOOD brand products.

During the warranty period, any authorized KENWOOD Service Center in the military market listed in the back of this warranty card will provide you free-of-charge both parts and labor required to correct any defect in materials or workmanship.

The following are not covered by this warranty.

- Voltage conversions.
- Periodic check-ups which do not disclose any defect covered by the warranty.
- Cabinets, grilles, other exterior finishes, belts, tape heads, and other non-durable parts and accessories.
- Units on which the serial number has been effaced, modified or removed.
- Installation and/or removal charges.
- Damaged magnetic tapes.
- House call charges for any repairs.
- Shipping or delivery charges to or from an authorized KENWOOD Service Center.
- This warranty will not cover any failure that is due to any of the following conditions in accordance with the visual inspection of the authorized KENWOOD Service Center:
 - * Improper maintenance or repair, including the installation of parts or accessories that do not conform to the quality and specifications of the original parts.
 - * Misuse, abuse, neglect, unauthorized product modification or failure to follow instructions contained in the Owner's Manual.
 - * Accidental or intentional damages.
 - * Repairs or attempted repairs by an unauthorized agency. (All repairs must be performed at an authorized KENWOOD Service Center.)
 - * Damages or deteriorations caused during shipment (Claims must be presented to the carrier).
 - * Damages or deteriorations resulting from removal and/or replacement.

PURCHASER'S RESPONSIBILITIES

As the purchaser of a new KENWOOD brand product, you are requested to do the following in order to obtain KENWOOD warranty service.

- Retain your sales slip or other evidence of purchase for proving your eligibility for requesting KENWOOD warranty service.
- Make your unit available to an authorized KENWOOD Service Center in the military market for inspection and approved warranty service, or ship your unit in its original carton box or equivalent, fully insured and shipping charges prepaid, to the authorized KENWOOD Service Center.

LIMITATION OF IMPLIED WARRANTIES

Any and all implied warranties, including warranties of merchantability and fitness for a particular purpose, shall be limited in duration to the length of this warranty.

EXCLUSION OF CERTAIN DAMAGES

KENWOOD's liability for any defective product is limited to the repair or replacement of said product, at our option, and shall not include damages of any kind, whether incidental, consequential or otherwise, except to the extent prohibited by applicable law.

ATTENTION

This card and receipt (or invoice) are necessary to purchase a new panel in case of theft or damage.

KENWOOD AUTHORIZED SERVICE CENTERS IN MILITARY MARKET

JAPAN:

Yokota
KENWOOD Rep.; c/o
Yokota BX, JAAX AAFES-PAC,
APO San Francisco 96328

Zama
KENWOOD Rep.; c/o
Zama PX, JAAX AAFES-PAC,
APO San Francisco 96343

Misawa
KENWOOD Rep.; c/o
Misawa BX, JAAX AAFES-PAC,
APO San Francisco 96519

Yokosuka
KENWOOD Rep.; c/o
A-33, Yokosuka NEX No. 260-010
FPO Seattle 98760

Atsugi
KENWOOD Rep.; c/o
Atsugi NEX No. 260-020 FPO Seattle 98767

Iwakuni
KENWOOD Rep.; c/o
Marine Corps Exchange, Marine Corps Air Station,
FPO Seattle 98764

Sasebo
Sasebo NEX;
Navy Exchange 260-040
F.A. Box 115 FPO Seattle 98766

Okinawa
KENWOOD Rep.; c/o
OWAX, AAFES-PAC, APO San Francisco 96230

KOREA:
KENWOOD Rep.; c/o
KOAX Repair Shop, AAFES-PAC
DD-Camp Market, APO San Francisco 96488

GUAM:
KENWOOD Rep.; c/o
Guam NEX No. 230-010,
FPO San Francisco 96630
KENWOOD Rep.; c/o
GUAX, AAFES-PAC, APO San Francisco 96334

U.S.A.:

In The Continental U.S.A.
For Nearest Authorized Service Center;
Tel: 1-800-536-9663
www.us.jvckenwood.com

EUROPE:

Please inquire at the military resale outlets where you bought your KENWOOD products, or
JVCKENWOOD DEUTSCHLAND GMBH:
Konrad-Adenauer Allee 1-11, 61118 Bad Vilbel, Germany

KENWOOD WARRANTY

JVCKENWOOD Canada Inc. (hereinafter called "KENWOOD"), gives the following written warranty to the original customer of each new KENWOOD product distributed in Canada by KENWOOD and purchased from a dealer authorized by KENWOOD.

KENWOOD warrants that each new KENWOOD product, under normal use, is free from any defects, subject to the terms and conditions set forth below. If a defect should occur within the warranty period, repairs will be made free of charge for parts and labour when such defects are determined by KENWOOD or its' authorized service centres to be attributable to faulty materials or workmanship at time of manufacture. Please contact KENWOOD to confirm if a dealer or service centre is authorized by KENWOOD.

WARRANTY PERIOD

This KENWOOD product is warranted for parts and labour for a period of one (1) year from the date of original purchase, lease or rental, except for products which are used in a professional or commercial application, which are warranted for a period of ninety (90) days for parts and labour and are subject to the terms and conditions of the warranty.

WARRANTY EXCLUSIONS

This warranty excludes:

- Products purchased in a foreign country or purchased in Canada and taken to a foreign country.
- Products purchased from a dealer not authorized by KENWOOD.
- Products with the serial number defaced, altered or missing.
- Periodic check-ups which do not disclose any defects covered by this warranty.
- Defects resulting from disaster, accident, abuse, misuse, lightning, power surges, neglect or lack of periodic maintenance, unauthorized modification or failure to follow instructions in the owner's manual.
- Defects or damage as a result of repairs performed by a person or party not authorized by KENWOOD.
- Defects resulting from the use of parts or devices that do not conform to KENWOOD specifications.
- Damage or deterioration occurring to any exterior finishes, cosmetic parts, tape heads, adaptors, antennas, cables, tapes, discs or faults or damage caused by defective or leaking batteries.
- Defects or damage occurring during shipping (claims should be presented to the shipping company).
- Product voltage and /or line frequency conversions.
- Product installation or removal charges.

TO OBTAIN WARRANTY SERVICE

Should your KENWOOD product require warranty service, deliver it to any authorized KENWOOD service centre and present the original copy of your bill of sale and this warranty card as proof of warranty, or send your product fully insured and freight prepaid to the nearest authorized KENWOOD service centre. To avoid possible shipping damage, make sure the product is properly packed. Include a copy of your original bill of sale and this warranty card as proof of warranty along with your name, home and /or work telephone number(s), a complete return address and a detailed description of the fault(s). Products repaired within warranty will be returned freight prepaid to destinations within Canada. The customer is responsible for all freight and related costs for the return of product(s) to destinations outside Canada.

ENTIRE WARRANTY

This warranty constitutes the entire written warranty given by KENWOOD. No person, party, dealer or service centre or their agents or employees are authorized to extend or enlarge this warranty on behalf of KENWOOD by any written or verbal statement or advertisement or promotion, including any extended warranty program or plan that may be offered by the dealer or service centre, unless approved in writing by KENWOOD.

DISCLAIMER

KENWOOD disclaims any responsibility for loss of time or use of the product or any other indirect, incidental or consequential damage to other products or goods, inconvenience or commercial loss.

NOTICE TO CONSUMER

The provisions contained in this written warranty are not intended to limit, modify, take away, disclaim or exclude any warranties or rights you may have which are set forth in any applicable provincial or federal laws or legislation.

IMPORTANT

This warranty card by itself is not considered by KENWOOD as a valid proof of purchase. When applying for warranty repairs, you must present the original copy of your bill of sale and this warranty card as proof of warranty, so we recommend that they be kept in a safe place, should they be required in the future.

JVCKENWOOD Canada Inc.
6070 Kestrel Road, Mississauga, Ontario, Canada L5T 1S8
Tel.: (905) 670-7211
Fax: (905) 670-7248

ATTENTION

This card and receipt (or invoice) are necessary to purchase a new panel in case of theft or damage.

GARANTIE KENWOOD

JVCKENWOOD Canada Inc. (ci-après appelée "KENWOOD"), donne par écrit la garantie suivante à l'acheteur original de chaque nouveau produit KENWOOD distribué au Canada par KENWOOD et acheté à un concessionnaire autorisé par KENWOOD.

KENWOOD garantit, sous réserve des termes et des conditions énoncés ci-dessous, que chaque nouveau produit KENWOOD, dans des conditions d'emploi normales, est exempt de tous défauts. Si l'un défaut se produit pendant la période de garantie, KENWOOD s'engage à assumer le coût des pièces défectueuses et de la main-d'oeuvre nécessaires pour effectuer les réparations pourvu que de tels défauts sont attribuables à des pièces défectueuses employées lors de la fabrication du produit KENWOOD ou à la main-d'oeuvre tel qu'établi par KENWOOD ou par l'un de ses centres de service autorisés. Appelez KENWOOD pour vérifier si un concessionnaire ou un centre de service est autorisé par KENWOOD.

PÉRIODE DE GARANTIE

Les pièces et la main-d'oeuvre nécessaires pour la réparation des produits KENWOOD sont garanties pendant la période d'un (1) an à compter de la date d'achat, de bail ou de location originale, sauf dans les cas où les produits KENWOOD sont employés dans un but professionnel ou commercial, où la garantie des pièces et de la main-d'oeuvre demeure en vigueur pendant une période de quatre-vingt-dix (90) jours sous réserve des termes et des conditions de la garantie.

EXCLUSIONS DE GARANTIE

Cette garantie ne couvre pas:

- les produits achetés à l'étranger ou achetés au Canada et transportés à l'étranger;
- les produits achetés à un concessionnaire non autorisé par KENWOOD;
- les produits dont le numéro de série manque, a été effacé ou modifié;
- les services d'entretien périodiques qui n'indiquent aucun défaut couvert par cette garantie;
- les défauts causés par les désastres, les accidents, les abus, les emplois incorrects, les éclairs, les surtensions de courant, les manques de soins ou d'entretiens périodiques, les modifications non autorisées ou les manques de respect du mode d'emploi;
- les défauts ou les dommages causés lors de réparations effectuées par une personne ou par une partie non autorisée par KENWOOD;
- les défauts causés par l'emploi de pièces ou de dispositifs qui ne se conforment pas aux exigences de KENWOOD;
- les finitions extérieures, les pièces cosmétiques, les têtes de bandes, les adaptateurs, les antennes, les câbles, les bandes, les disques endommagés ou déperis, ni les défauts ou dommages causés par des piles défectueuses ou qui fuient;
- les défauts ou dommages qui se produisent pendant l'expédition des produits KENWOOD (On devrait déposer de telles réclamations auprès des compagnies de transport);
- les conversions de tension et/ou de fréquence du produit;
- les frais d'installation ou d'enlèvement du produit.

COMMENT OBTENIR DU SERVICE SOUS GARANTIE

Au cas où un service sous garantie de votre produit KENWOOD s'avère nécessaire, veuillez livrer le produit à n'importe quel centre de service KENWOOD et présenter la copie originale du contrat de vente et cette carte de garantie en tant que preuve de garantie ou veuillez faire parvenir votre produit assuré et port payé au centre de service KENWOOD autorisé le plus proche. Pour éviter toutes possibilités de dommages pendant le transport, veuillez bien emballer le produit. Veuillez inclure une copie du contrat de vente original et cette carte de garantie en tant que preuve de garantie aussi bien que votre nom, numéros de téléphone au poste de travail et/ou au domicile, votre adresse et une description détaillée des défauts. Les produits sous garantie réparés seront retournés port payé aux destinations à l'intérieur du Canada. Le consommateur sera responsable de tous frais de transport et d'autres frais qui s'y rapportent pour faire expédier les produits à destinations à l'extérieur du Canada.

L'ENTIÈRE GARANTIE

Cette garantie représente l'entière garantie donnée par écrit par KENWOOD. KENWOOD ne se tient aucunement responsable de toutes extensions ni de toutes augmentations de cette garantie faites ou entreprises par toutes personnes, parties, concessionnaires ou centres de service ou par leurs agents ou employés au nom de KENWOOD au moyen d'affirmations verbales ou écrites, d'annonces ou de promotions, y inclus tous programmes ou plans de garantie étendue que puissent offrir les concessionnaires ou les centres de service, à moins que KENWOOD n'y ait consenti par écrit d'avance.

RENONCIATION

KENWOOD renonce à toutes responsabilités de perte de temps, d'emploi du produit, de tous dommages indirects ou accessoires causés à d'autres produits ou biens, de tous inconvénients ou de toutes pertes commerciales.

AVIS AUX CONSOMMATEURS

Les stipulations contenues dans la présente garantie écrite n'ont pas pour but de limiter, de modifier, de diminuer, de rejeter ni d'exclure d'autres garanties ni droits énoncés dans n'importe quelles lois ou législations provinciales ou fédérales.

IMPORTANT

KENWOOD ne considère pas cette garantie toute seule comme étant une preuve d'achat valide. Lorsqu'on demande du service sous garantie, il faudra présenter la copie originale du contrat de vente aussi bien que cette carte de garantie en tant que preuve de garantie. On recommande de les conserver dans un lieu sûr au cas où elles s'avèreraient nécessaires à l'avenir.

JVCKENWOOD Canada Inc.
6070 Kestrel Road, Mississauga, Ontario, Canada L5T 1S8
Téléphone: (905) 670-7211
Télécopieur: (905) 670-7248

ATTENTION

La carte de garantie et la preuve d'achat (ou la facture) sont nécessaires à l'achat d'une nouvelle façade détachable en cas de dommages ou de vol.

Andorra

Estimado Usuario de los productos KENWOOD:

Gracias por haber elegido este Producto KENWOOD.

Si resulta defectuoso bajo condiciones normales de funcionamiento, le rogamos que contacte con su distribuidor autorizado más abajo indicado, para información acerca de la garantía.

JVCKENWOOD EUROPE B.V. Sucursal en España
Carretera de Rubí, 88
008174 Sant Cugat del Vallès, Barcelona
Tel. + 34-93-507-5252
www.kenwood.es

ATENCIÓN

Esta tarjeta y un recibo (o factura) son necesarios para adquirir una carátula nueva en caso de robo o daño de la misma.

Iceland

Kæri notandi KENWOOD tækja.

Til hamingju með n'yja KENWOOD tækið þitt. Ef einhverjir framleiðslugallar koma í ljós við venjulega notkun vinsamlegast hafðu samband við umboðsmann KENWOOD á Íslandi.

JVCKENWOOD Europe B.V.
Amsterdamseweg 37
1422 AC Uithoorn
The Netherlands
+31 (0) 297 - 519 900
www.kenwood.eu

Ábyrgðartími er eitt ár frá kaupdegi að telja. Kaupandi skal flytja tækið til og frá verkstæði á eigin kostnað. Að öðru leiti skal viðgerð á framleiðslugöllum fara fram kaupanda að kostnaðarlausu.

Nánari upplýsingar um ábyrgðarskilmála veitir umboðsmaður.

ATHYGLI

Þetta ábyrgðarkort og reikningur eru nauðsynleg til að kaup nýjan front ef honum er stolið eða hann skemmt.

Malta

Chaziz Klijent tal-Prodotti KENWOOD,

Grazzi talli ghazilt dan il-prodott "KENWOOD".

Jekk qatt jinjalalu xi difett waqt l-uzu normali tieghu, jekk joghogbok ghamel kuntatt mad-Distributur Awtorizzat ta' pajjizek li qieghed imnizzel f'din il-lista ghall-informazzjoni, dwar garanzija.

JVCKENWOOD Europe B.V.
Amsterdamseweg 37
1422 AC Uithoorn
The Netherlands
+31 (0) 297 - 519 900
www.kenwood.eu

ATTENZJONI

Il-karta tal-garanzija flimkien ma l-ircevuta fiskali huma necessarji biex tixtri faccata għada għas-set tieghek f'kas ta' serg jew hsara.

Norge

Kjære kunde,

Takk for at De valgte dette KENWOOD-produktet.

Hvis det oppstår feil under normal bruk, vennligst ta kontakt med en av de autoriserte forhandlerne som er oppført nedenfor vedrørende reklamasjon/garanti.

JVCKENWOOD Europe B.V.
Amsterdamseweg 37
1422 AC Uithoorn
The Netherlands
+31 (0) 297 - 519 900
www.kenwood.eu

OBS!

Dette kort og kvittering er nødvendig for å kjøpe nytt panel ved eventuell skade eller tyveri.

Schweiz

Sehr geehrter Benutzer von KENWOOD Produkten:

Herzlichen Dank, dass Sie sich für dieses KENWOOD-Produkt entschieden haben.

Falls ein Defekt unter normalen Betriebsbedingungen eintreten sollte, wenden Sie sich bitte an Ihre offizielle KENWOOD-Vertretung.

Eine Liste aller KENWOOD-Fachhändler sowie alle Informationen zur Garantie finden Sie unter www.kenwood.de

JVCKENWOOD DEUTSCHLAND GMBH
Konrad-Adenauer Allee 1-11
61118 Bad Vilbel
Tel. 0840 - 6666 01
www.kenwood.de

ZUR BEACHTUNG

Diese Garantiekarte und der Kaufbeleg werden benötigt, um im Falle des Verlustes ein neues Bedienteil zu erwerben.

Svizzera

Gentile cliente, la ringraziamo per aver acquistato questo prodotto KENWOOD.

Se, in normali condizioni di funzionamento, questo dovesse risultare difettoso, la preghiamo di contattare il nostro distributore ufficiale al seguente indirizzo.

Tale nostro distributore sarà a sua disposizione per qualunque informazione.

JVCKENWOOD DEUTSCHLAND GMBH
Konrad-Adenauer Allee 1-11
61118 Bad Vilbel
Tel. 0840 - 6666 01
www.kenwood.de

ATTENZIONE

Questo documento e la ricevuta d'acquisto (o fattura) sono necessari per l'acquisto di un nuovo frontalino in caso di furto o danno.

Suisse

Cher utilisateur de KENWOOD,

Merci d'avoir choisi ce produit de KENWOOD.

En cas de panne sous conditions d'opérations normales, veuillez s.v.p. contacter votre distributeur officiel mentionné ci-dessous. Il est à votre disposition pour toutes informations de garantie.

JVCKENWOOD DEUTSCHLAND GMBH
Konrad-Adenauer Allee 1-11
61118 Bad Vilbel
Tel. 0840 - 6666 01
www.kenwood.de

ATTENTION

La carte de garantie et la preuve d'achat (ou la facture) sont nécessaires à l'achat d'une nouvelle façade détachable en cas de dommages ou de vol.

Sverige

Bäste KENWOOD kund!

Tack för att Ni valt denna KENWOOD-produkt.

För KENWOOD-produkter sålda i Sverige gäller Konsumentköp RR91. Om Er KENWOOD-produkt inte fungerar korrekt eller är felaktig, under normalt handhavande, ber vi Er kontakta återförsäljaren (inköpsstället).

JVCKENWOOD Europe B.V.
Amsterdamseweg 37
1422 AC Uithoorn
The Netherlands
+31 (0) 297 - 519 900
www.kenwood.eu

OBS!

Detta kort och inköpskvitto är nödvändigt att ha för att kunna köpa en ny front vid eventuell skada eller stöld.

Dear Customer,

Thank you for purchasing this kenwood product. As mentioned in the pages of this booklet, our warranty is only valid in the countries listed. If your country is not listed please contact your retailer for information on warranty procedure, or write to:

JVC KENWOOD Customer Information Center
3-12, Moriyacho,
Kanagawa-ku, Yokohama-shi, Kanagawa
221-0022, Japan

