

# KENWOOD

PERFORMANCE  
SERIES



For Your / Pour Votre ■ FORD ■ MAZDA

## Factory Location Fit

Designed for Easy Replacement using Existing Speaker Locations  
Conçu pour un remplacement facile en utilisant l'emplacement des haut-parleurs existants

PEAK POWER

**320**<sub>w</sub>

**5x7**<sub>in</sub>

Custom Fit Speaker

HAUT-PARLEURS PERSONNALISÉS  
ALTAVOCES PARA PREINSTALACIÓN

# KFC-C5796PS

# KFC-C5796PS

INSTRUCTIONS / INSTRUCTIONS / INSTRUCCIONES

CUSTOM FIT SPEAKER  
HAUT-PARLEURS PERSONNALISÉS  
ALTAVOCES PARA PREINSTALACIÓN

## Installation / Installation / Instalación

Rear Deck  
Plage arrière  
Estantería trasera

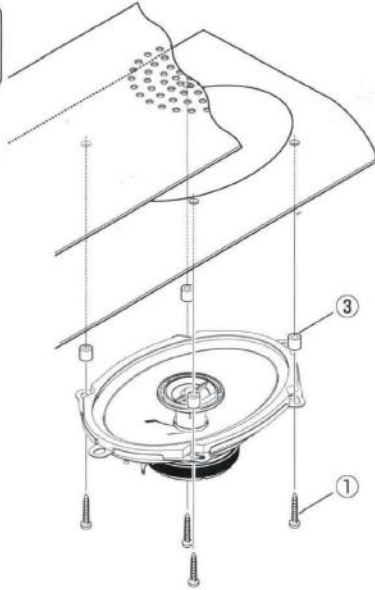

Rear Side Panel  
Côté arrière  
Panel lateral trasero

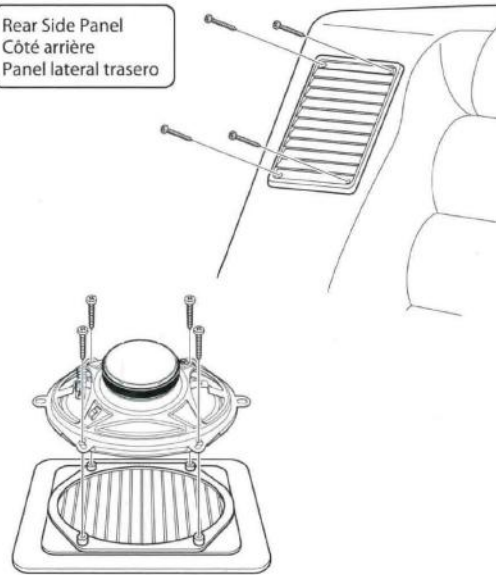

Door Panel  
Panneau de portière  
Panel de puerta

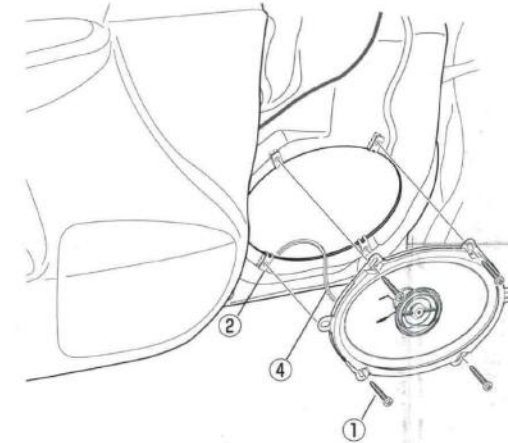

## Parts / Pièces / Piezas

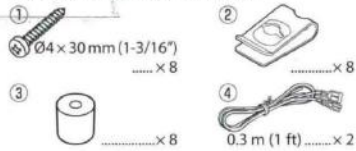

## Dimensions / Dimensions / Dimensiones

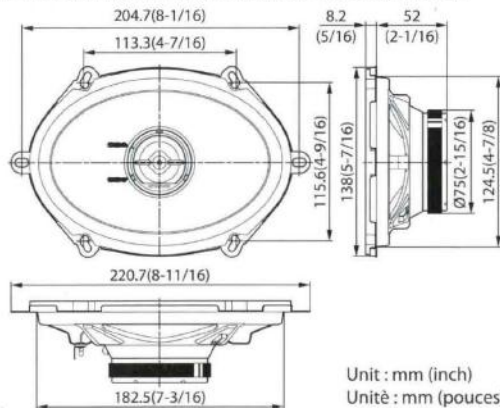

## Connections / Raccordements / Conexiones

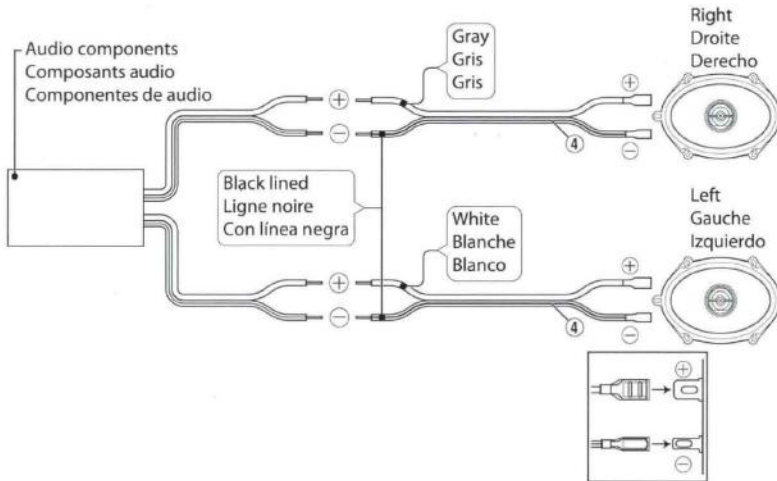

## Specifications

Woofer : 13.8 x 19.5 cm (5 x 7") Cone  
Tweeter : 3 cm (1-3/16") Balanced Dome  
Peak Power : 320 W  
RMS Power : 80 W  
Impedance : 4 Ω  
Sensitivity : 88 dB / W at 1 m  
Frequency Response : 64 ~ 24,000 Hz  
Weight of magnet : 190 g (6.7 oz)

## Spécifications

Graves : 13,8 x 19,5 cm (5 x 7") Cône  
Aigus : 3 cm Dôme équilibré  
Puissance de crête : 320 W  
RMS Puissance : 80 W  
Impédance : 4 Ω  
Sensibilité : 88 dB / W à 1 m  
Réponse en fréquence : 64 ~ 24.000 Hz  
Poids de l'aimant : 190 g

## Especificaciones

Altavoz de graves : 13,8 x 19,5 cm (5 x 7") Cono  
Altavoz de agudos : 3 cm Cúpula balanceada  
Potencia pico : 320 W  
Potencia RMS : 80 W  
Impedancia : 4 Ω  
Sensibilidad : 88 dB / W a 1 m  
Respuesta de frecuencia : 64 ~ 24.000 Hz  
Peso del imán : 190 g

VOLUME 0.0054 m<sup>3</sup> / 0.19 ft<sup>3</sup>  
WEIGHT / POIDS 1.5 kg / 3.3 lb

JVCKENWOOD Corporation

Yokohama 221-0022 Japan

Made in China / Fabriqué en Chine

Designed and Engineered in Japan / Design et Conception au Japon





## IMPORTANT SAFETY INSTRUCTIONS

**▲ CAUTION** To avoid the risk of human injury or property damage, be sure to read and observe the following safety precautions.

**Consult a professional technician for installing and connecting the speaker.** — Incorrect installation may lead to traffic accidents or malfunctions.

**Avoid installation where the speaker is unstable.** — Make sure that the speaker is stationary and does not rattle. Displacement of the speaker may cause injury.

**Do not modify the speaker.** — Doing so may result in smoke or fire.

**Do not place hands on the speaker.** — The speaker becomes hot after extended operation. Touching it in such a condition may cause burns.

**Keep the volume of sound at an optimum level.** — Not being able to hear sounds from outside of your car can lead to traffic accidents.

**In case of abnormality, stop the use and disconnect the speaker.** — If operation is continued, smoke or fire may result. Disconnect the speaker and ask servicing.

---

### FOR PROPER INSTALLATION AND USE

**Please read the instructions carefully before using this speaker.**

- Be careful not to accidentally kick or apply any sort of strong impact to the speaker.
- To prevent damaging the speaker, turn off the power of the amplifier before connecting it to the speaker.
- Do not use the provided parts for other purposes (Ex. using a speaker cord instead of a power cord). Otherwise malfunction or fire hazard could result.

# KENWOOD Warranty Card

Dear Customer,

Thank you for purchasing this Kenwood product. As mentioned in the pages of this booklet, our warranty is only valid in the countries listed. If your country is not listed please contact your retailer for information on warranty procedure, or write to:

**JVC KENWOOD Customer Information Center**

3-12, Moriyacho,  
Kanagawa-ku, Yokohama-shi, Kanagawa  
221-0022, Japan

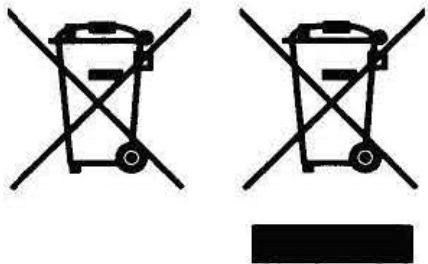

This warranty will be honored only in the U.S.A.

## KENWOOD LIMITED WARRANTY FOR CAR STEREO COMPONENTS

### HOW LONG IS THE WARRANTY

JVCKENWOOD USA Corporation ("KENWOOD") warrants this product for a period of one (1) year from the date of original purchase.

### WHAT IS COVERED AND WHAT IS NOT COVERED

Except as specified below, this warranty covers all defects in material and workmanship in KENWOOD car stereo components. The following are not covered by the warranty:

1. Any product which is not distributed in the U.S.A. by KENWOOD or which is not purchased in the U.S.A. from an authorized KENWOOD car stereo dealer or an automobile dealer, unless the product is purchased through the U.S.A Military Exchange Service.
2. Any product on which the serial number has been defaced, modified or removed.
3. Damage, deterioration or malfunction resulting from:
  - a. Any shipment of the product (claims must be presented to the carrier).
  - b. Installation or removal of the product.
  - c. Accident, acts of nature, misuse, abuse, neglect, unauthorized product modification or failure to follow instructions supplied with the product.
  - d. Repair or attempted repair by anyone not authorized by KENWOOD.
  - e. Any other cause which does not relate to a product defect.

### WHO IS PROTECTED

This warranty is enforceable only by the original purchaser.

### WHAT WE WILL PAY FOR

We will pay for all labor and material expenses for covered items. Payment of shipping charges is discussed in the next section of this warranty.

### HOW TO OBTAIN WARRANTY SERVICE

If your KENWOOD product ever needs service:

1. Take or ship it to any KENWOOD Authorized Service Center in the U.S.A. along with & complete description of the problem. (if you are uncertain as to whether a Service Center is authorized, please call **1-800-KENWOOD** for the nearest Service Center. **1-800-536-9663**).
2. Although you must pay any shipping charges if it is necessary to ship the product for warranty service, we will pay the return shipping charges if the repairs are covered by the warranty within the United States.
3. Whenever your units are taken or sent for warranty service, you must include a copy of the original dated sales receipt as proof of warranty coverage.

### LIMITATION OF IMPLIED WARRANTIES

ALL IMPLIED WARRANTIES, INCLUDING WARRANTIES OF MERCHANTABILITY AND FITNESS FOR A PARTICULAR PURPOSE, ARE LIMITED IN DURATION TO THE LENGTH OF THIS WARRANTY.

### EXCLUSION OF DAMAGES

KENWOOD'S LIABILITY FOR ANY DEFECTIVE PRODUCT IS LIMITED TO THE REPAIR OR REPLACEMENT OF THE PRODUCT AT OUR OPTION. KENWOOD SHALL NOT BE LIABLE FOR:

1. INSTALLATION OR REMOVAL CHARGES, DAMAGE TO OTHER PROPERTY CAUSED BY ANY DEFECTS IN KENWOOD CAR STEREO COMPONENTS, DAMAGES BASED UPON INCONVENIENCE, LOSS OF USE OF THE PRODUCT; OR
2. ANY OTHER DAMAGES, WHETHER INCIDENTAL, CONSEQUENTIAL OR OTHERWISE.

SOME STATES DO NOT ALLOW LIMITATIONS ON HOW LONG AN IMPLIED WARRANTY LASTS AND/OR DO NOT ALLOW THE EXCLUSION OR LIMITATION OF INCIDENTAL OR CONSEQUENTIAL DAMAGES, SO THE ABOVE LIMITATIONS AND EXCLUSIONS MAY NOT APPLY TO YOU.

This warranty gives you specific legal rights, and you may also have other rights which vary from state to state.

If a problem develops during or after the Limited Warranty Period, or if you have any questions regarding the operation of the product, you should contact your KENWOOD Authorized Dealer or Authorized Service Center. If the problem or your question is not handled to your satisfaction, please contact our Customer Relations Department at the address listed below:

**JVCKENWOOD USA Corporation**  
PO Box 22745, 2201 E. Dominguez St. Long Beach, CA 90810-5745  
Tel: (800) 536-9663  
[www.us.jvckenwood.com](http://www.us.jvckenwood.com)

### ATTENTION

This card and receipt (or invoice) are necessary to purchase a new panel in case of theft or damage.



## MILITARY

Units purchased through the U.S.A. military exchange service overseas may be serviced under warranty in the continental U.S.A., subject to the following conditions.

- 1) The original warranty is in effect.
- 2) Proof of purchase is provided to the servicer.

### WARRANTY FOR MILITARY MARKET

JVC KENWOOD corporation is proud of the quality and workmanship of its audio equipment. This unit has been properly designed, tested and inspected before it was shipped to you. If properly installed and operated in accordance with instructions furnished, it should give you an optimum reliable performance.

#### WARRANTY PERIOD

This product is warranted for a period of (1) year from the date of the original purchase.

#### SCOPE OF WARRANTY

Except as specified below, this warranty covers all defects in materials and workmanship of the KENWOOD brand products.

During the warranty period, any authorized KENWOOD Service Center in the military market listed in the back of this warranty card will provide you free-of-charge both parts and labor required to correct any defect in materials or workmanship.

The following are not covered by this warranty.

1. Voltage conversions.
2. Periodic check-ups which do not disclose any defect covered by the warranty.
3. Cabinets, grilles, other exterior finishes, belts, tape heads, and other non-durable parts and accessories.
4. Units on which the serial number has been effaced, modified or removed.
5. Installation and/or removal charges.
6. Damaged magnetic tapes.
7. House call charges for any repairs.
8. Shipping or delivery charges to or from an authorized KENWOOD Service Center.
9. This warranty will not cover any failure that is due to any of the following conditions in accordance with the visual inspection of the authorized KENWOOD Service Center:
  - \* Improper maintenance or repair, including the installation of parts or accessories that do not conform to the quality and specifications of the original parts.
  - \* Misuse, abuse, neglect, unauthorized product modification or failure to follow instructions contained in the Owner's Manual.
  - \* Accidental or intentional damages.
  - \* Repairs or attempted repairs by an unauthorized agency. (All repairs must be performed at an authorized KENWOOD Service Center.)
  - \* Damages or deteriorations caused during shipment (Claims must be presented to the carrier).
  - \* Damages or deteriorations resulting from removal and/or replacement.

#### PURCHASER'S RESPONSIBILITIES

As the purchaser of a new KENWOOD brand product, you are requested to do the following in order to obtain KENWOOD warranty service.

1. Retain your sales slip or other evidence of purchase for proving your eligibility for requesting KENWOOD warranty service.
2. Make your unit available to an authorized KENWOOD Service Center in the military market for inspection and approved warranty service, or ship your unit in its original carton box or equivalent, fully insured and shipping charges prepaid, to the authorized KENWOOD Service Center.

#### LIMITATION OF IMPLIED WARRANTIES

Any and all implied warranties, including warranties of merchantability and fitness for a particular purpose, shall be limited in duration to the length of this warranty.

#### EXCLUSION OF CERTAIN DAMAGES

KENWOOD's liability for any defective product is limited to the repair or replacement of said product, at our option, and shall not include damages of any kind, whether incidental, consequential or otherwise, except to the extent prohibited by applicable law.

#### ATTENTION

This card and receipt (or invoice) are necessary to purchase a new panel in case of theft or damage.

## KENWOOD AUTHORIZED SERVICE CENTERS IN MILITARY MARKET

### JAPAN:

#### Yokota

KENWOOD Rep.; c/o  
Yokota BX, JAAX AAFES-PAC,  
APO San Francisco 96328

#### Zama

KENWOOD Rep.; c/o  
Zama PX, JAAX AAFES-PAC,  
APO San Francisco 96343

#### Misawa

KENWOOD Rep.; c/o  
Misawa BX, JAAX AAFES-PAC,  
APO San Francisco 96519

#### Yokosuka

KENWOOD Rep.; c/o  
A-33, Yokosuka NEX No. 260-010  
FPO Seattle 98760

#### Atsugi

KENWOOD Rep.; c/o  
Atsugi NEX No. 260-020 FPO Seattle 98767

#### Iwakuni

KENWOOD Rep.; c/o  
Marine Corps Exchange, Marine Corps Air Station,  
FPO Seattle 98764

#### Sasebo

Sasebo NEX;  
Navy Exchange 260-040  
F.A. Box 115 FPO Seattle 98766

#### Okinawa

KENWOOD Rep.; c/o  
OWAX, AAFES-PAC, APO San Francisco 96230

### KOREA:

KENWOOD Rep.; c/o  
KOAX Repair Shop, AAFES-PAC  
DD-Camp Market, APO San Francisco 96488

### GUAM:

KENWOOD Rep.; c/o  
Guam NEX No. 230-010,  
FPO San Francisco 96630  
KENWOOD Rep.; c/o  
GUAX, AAFES-PAC, APO San Francisco 96334

### U.S.A.:

**In The Continental U.S.A.**  
For Nearest Authorized Service Center;  
Tel: 1-800-536-9663  
[www.us.jvckenwood.com](http://www.us.jvckenwood.com)

### EUROPE:

Please inquire at the military resale outlets where you bought your KENWOOD products, or  
JVCKENWOOD DEUTSCHLAND GMBH:  
Konrad-Adenauer Allee 1-11, 61118 Bad Vilbel, Germany

**KENWOOD WARRANTY**

JVCKENWOOD Canada Inc. (hereinafter called "KENWOOD"), gives the following written warranty to the original customer of each new KENWOOD product distributed in Canada by KENWOOD and purchased from a dealer authorized by KENWOOD.

KENWOOD warrants that each new KENWOOD product, under normal use, is free from any defects, subject to the terms and conditions set forth below. If a defect should occur within the warranty period, repairs will be made free of charge for parts and labour when such defects are determined by KENWOOD or its' authorized service centres to be attributable to faulty materials or workmanship at time of manufacture. Please contact KENWOOD to confirm if a dealer or service centre is authorized by KENWOOD.

**WARRANTY PERIOD**

This KENWOOD product is warranted for parts and labour for a period of one (1) year from the date of original purchase, lease or rental, except for products which are used in a professional or commercial application, which are warranted for a period of ninety (90) days for parts and labour and are subject to the terms and conditions of the warranty.

**WARRANTY EXCLUSIONS**

This warranty excludes:

- (a) Products purchased in a foreign country or purchased in Canada and taken to a foreign country.
- (b) Products purchased from a dealer not authorized by KENWOOD.
- (c) Products with the serial number defaced, altered or missing.
- (d) Periodic check-ups which do not disclose any defects covered by this warranty.
- (e) Defects resulting from disaster, accident, abuse, misuse, lightning, power surges, neglect or lack of periodic maintenance, unauthorized modification or failure to follow instructions in the owner's manual.
- (f) Defects or damage as a result of repairs performed by a person or party not authorized by KENWOOD.
- (g) Defects resulting from the use of parts or devices that do not conform to KENWOOD specifications.
- (h) Damage or deterioration occurring to any exterior finishes, cosmetic parts, tape heads, adaptors, antennas, cables, tapes, discs or faults or damage caused by defective or leaking batteries.
- (i) Defects or damage occurring during shipping (claims should be presented to the shipping company).
- (j) Product voltage and/or line frequency conversions.
- (k) Product installation or removal charges.

**TO OBTAIN WARRANTY SERVICE**

Should your KENWOOD product require warranty service, deliver it to any authorized KENWOOD service centre and present the original copy of your bill of sale and this warranty card as proof of warranty, or send your product fully insured and freight prepaid to the nearest authorized KENWOOD service centre. To avoid possible shipping damage, make sure the product is properly packed. Include a copy of your original bill of sale and this warranty card as proof of warranty along with your name, home and/or work telephone number(s), a complete return address and a detailed description of the fault(s). Products repaired within warranty will be returned freight prepaid to destinations within Canada. The customer is responsible for all freight and related costs for the return of product(s) to destinations outside Canada.

**ENTIRE WARRANTY**

This warranty constitutes the entire written warranty given by KENWOOD. No person, party, dealer or service centre or their agents or employees are authorized to extend or enlarge this warranty on behalf of KENWOOD by any written or verbal statement or advertisement or promotion, including any extended warranty program or plan that may be offered by the dealer or service centre, unless approved in writing by KENWOOD.

**DISCLAIMER**

KENWOOD disclaims any responsibility for loss of time or use of the product or any other indirect, incidental or consequential damage to other products or goods, inconvenience or commercial loss.

**NOTICE TO CONSUMER**

The provisions contained in this written warranty are not intended to limit, modify, take away, disclaim or exclude any warranties or rights you may have which are set forth in any applicable provincial or federal laws or legislation.

**IMPORTANT**

This warranty card by itself is not considered by KENWOOD as a valid proof of purchase. When applying for warranty repairs, you must present the original copy of your bill of sale and this warranty card as proof of warranty, so we recommend that they be kept in a safe place, should they be required in the future.

JVCKENWOOD Canada Inc.  
6070 Kestrel Road, Mississauga, Ontario, Canada L5T 1S8  
Tel.: (905) 670-7211  
Fax: (905) 670-7248

**ATTENTION**

This card and receipt (or invoice) are necessary to purchase a new panel in case of theft or damage.

**GARANTIE KENWOOD**

JVCKENWOOD Canada Inc. (ci-après appelée "KENWOOD"), donne par écrit la garantie suivante à l'acheteur original de chaque nouveau produit KENWOOD distribué au Canada par KENWOOD et acheté à un concessionnaire autorisé par KENWOOD.

KENWOOD garantit, sous réserve des termes et des conditions énoncés ci-dessous, que chaque nouveau produit KENWOOD, dans des conditions d'emploi normales, est exempt de tous défauts. Si l'un défaut se produit pendant la période de garantie, KENWOOD s'engage à assumer le coût des pièces défectueuses et de la main-d'oeuvre nécessaires pour effectuer les réparations pourvu que de tels défauts sont attribuables à des pièces défectueuses employées lors de la fabrication du produit KENWOOD ou à la main-d'oeuvre tel qu'établi par KENWOOD ou par l'un de ses centres de service autorisés. Appelez KENWOOD pour vérifier si un concessionnaire ou un centre de service est autorisé par KENWOOD.

**PÉRIODE DE GARANTIE**

Les pièces et la main-d'oeuvre nécessaires pour la réparation des produits KENWOOD sont garanties pendant la période d'un (1) an à compter de la date d'achat, de bail ou de location originale, sauf dans les cas où les produits KENWOOD sont employés dans un but professionnel ou commercial, où la garantie des pièces et de la main-d'oeuvre demeure en vigueur pendant une période de quatre-vingt-dix (90) jours sous réserve des termes et des conditions de la garantie.

**EXCLUSIONS DE GARANTIE**

Cette garantie ne couvre pas:

- (a) les produits achetés à l'étranger ou achetés au Canada et transportés à l'étranger;
- (b) les produits achetés à un concessionnaire non autorisé par KENWOOD;
- (c) les produits dont le numéro de série manque, a été effacé ou modifié;
- (d) les services d'entretien périodiques qui n'indiquent aucun défaut couvert par cette garantie;
- (e) les défauts causés par les désastres, les accidents, les abus, les emplois incorrects, les éclairs, les surtensions de courant, les manques de soins ou d'entretiens périodiques, les modifications non autorisées ou les manques de respect du mode d'emploi;
- (f) les défauts ou les dommages causés lors de réparations effectuées par une personne ou par une partie non autorisée par KENWOOD;
- (g) les défauts causés par l'emploi de pièces ou de dispositifs qui ne se conforment pas aux exigences de KENWOOD;
- (h) les finitions extérieures, les pièces cosmétiques, les têtes de bandes, les adaptateurs, les antennes, les câbles, les bandes, les disques endommagés ou déperis, ni les défauts ou dommages causés par des piles défectueuses ou qui fuient;
- (i) les défauts ou dommages qui se produisent pendant l'expédition des produits KENWOOD (On devrait déposer de telles réclamations auprès des compagnies de transport);
- (j) les conversions de tension et/ou de fréquence du produit;
- (k) les frais d'installation ou d'enlèvement du produit.

**COMMENT OBTENIR DU SERVICE SOUS GARANTIE**

Au cas où un service sous garantie de votre produit KENWOOD s'avère nécessaire, veuillez livrer le produit à n'importe quel centre de service KENWOOD et présenter la copie originale du contrat de vente et cette carte de garantie en tant que preuve de garantie ou veuillez faire parvenir votre produit assuré et port payé au centre de service KENWOOD autorisé le plus proche. Pour éviter toutes possibilités de dommages pendant le transport, veuillez bien emballer le produit. Veuillez inclure une copie du contrat de vente original et cette carte de garantie en tant que preuve de garantie aussi bien que votre nom, numéros de téléphone au poste de travail et/ou au domicile, votre adresse et une description détaillée des défauts. Les produits sous garantie réparés seront retournés port payé aux destinations à l'intérieur du Canada. Le consommateur sera responsable de tous frais de transport et d'autres frais qui s'y rapportent pour faire expédier les produits à destinations à l'extérieur du Canada.

**L'ENTIERE GARANTIE**

Cette garantie représente l'entière garantie donnée par écrit par KENWOOD. KENWOOD ne se tient aucunement responsable de toutes extensions ni de toutes augmentations de cette garantie faites ou entreprises par toutes personnes, parties, concessionnaires ou centres de service ou par leurs agents ou employés au nom de KENWOOD au moyen d'affirmations verbales ou écrites, d'annonces ou de promotions, y inclus tous programmes ou plans de garantie étendue que puissent offrir les concessionnaires ou les centres de service, à moins que KENWOOD n'y ait consenti par écrit d'avance.

**RENONCIATION**

KENWOOD renonce à toutes responsabilités de perte de temps, d'emploi du produit, de tous dommages indirects ou accessoires causés à d'autres produits ou biens, de tous inconvénients ou de toutes pertes commerciales.

**AVIS AUX CONSOMMATEURS**

Les stipulations contenues dans la présente garantie écrite n'ont pas pour but de limiter, de modifier, de diminuer, de rejeter ni d'exclure d'autres garanties ni droits énoncés dans n'importe quelles lois ou législations provinciales ou fédérales.

**IMPORTANT**

KENWOOD ne considère pas cette garantie toute seule comme étant une preuve d'achat valide. Lorsqu'on demande du service sous garantie, il faudra présenter la copie originale du contrat de vente aussi bien que cette carte de garantie en tant que preuve de garantie. On recommande de les conserver dans un lieu sûr au cas où elles s'avèreraient nécessaires à l'avenir.

JVCKENWOOD Canada Inc.  
6070 Kestrel Road, Mississauga, Ontario, Canada L5T 1S8  
Téléphone: (905) 670-7211  
Télécopieur: (905) 670-7248

**ATTENTION**

La carte de garantie et la preuve d'achat (ou la facture) sont nécessaires à l'achat d'une nouvelle façade détachable en cas de dommages ou de vol.



Dear User of KENWOOD Products:

Thank you for having chosen this KENWOOD product (the "Product"). If it becomes defective under normal operating conditions, it will be repaired or replaced free of charge in conformity with the terms of this Warranty Card. In the event that the Product was purchased in any EEC Member State and you experience a problem, please take the Product to any official KENWOOD importer, Authorized Dealer, Authorized Service Centre or retailer of KENWOOD products in the EEC, together with the purchase receipt or other adequate proof of the date of purchase. If it was purchased outside the EEC, the Product must be taken to the retailer from whom it was purchased. If the Product was purchased in the EEC and you wish to know the location of your nearest Authorized Dealer in the EEC, please contact the following for information.

**JVCKENWOOD U.K. Limited**  
**12 Priestley Way, London, NW2 7BA**  
**Tel. 020 8208 7500**  
**www.kenwood-electronics.co.uk**

Please keep this Warranty Card as you will need it should a claim be necessary.

The Product is guaranteed for one year from the date of original purchase from any retailer of KENWOOD products. The guarantee covers both materials and workmanship, and the repair shall be carried out free of charge. We reserve the right to replace the Product if it cannot be repaired economically. Packaging, installation costs and any other costs or risks indirectly related to the actual repair, are not included in the warranty services and will be charged.

#### Conditions

A. Any claim under this warranty must be accompanied by this Warranty Card, and in addition:

- Your full name and address.
- The receipt or other document showing the date of purchase from a retailer established in Europe.
- The full name and address of the retailer from whom the Product was purchased.

(d) The Serial Number and Model name of the Product. If this information cannot be provided, or if the Product has been modified or altered in any way since the date of purchase, KENWOOD Corporation reserves the right to refuse to repair the Product under the terms of this Warranty.

B. The Product has been manufactured so that it complies with all national or local standards and safety requirements applicable in the country of first sale by the manufacturer in Europe. Modifications necessary for use elsewhere are not covered by this Warranty, and no liability for repair will be accepted in respect of any work done in this connection, or any damage to the Product arising from such work.

If the Product is used in a European country where it is subject to other standards and requirements than those applicable in the country of first sale by the manufacturer in Europe, then any warranty services will be subject to the condition that the user bear the cost of adapting the Product to the applicable standards and requirements. In addition, if the Product is different in type from those marketed by the official importer in the country where it is offered for warranty repair, and the appropriate spare parts are unavailable in this country or the warranty service cannot be provided in this country for another legitimate reason, then the cost of shipping the Product for repair to and from the country of original purchase shall be borne by the user.

C. This Warranty does not cover:

- alterations of the Product, and normal maintenance and adjustments, including periodic check-ups mentioned in the Manual used with the Product;
- damage to the Product caused by inadequate or improper repairs carried out by any person or entity which is not authorized by the manufacturer to perform warranty services on its behalf;
- damage to the Product caused by negligence, accidents, modifications, defective installation or packaging, misuse, and use of inappropriate spare parts;
- damage to the Product caused by fire, immersion in water, lightning, earthquake, inadequate ventilation, Acts of God, incorrect application of main voltage howsoever arising, or any other cause beyond the control of KENWOOD;

- loudspeakers damaged by application of power levels beyond the rated specification, and damages caused for whatever reason to records, tapes, cassette tapes, video tapes, compact disks, or any other goods which are not the Product itself;
- consumable or wearing items requiring replacement as part of normal service, including (but not limited to) phono-cartridges, stylus, drive belts, tape heads, racks, dry cells, rechargeable batteries and final tubes;
- the Product from which any or all of the serial numbers has been removed, modified or defaced;

This Warranty is available to any person who has legally obtained the Product.

Subject as mentioned above, the Product will be repaired or replaced free of charge. These rights in no way interfere with or otherwise affect the rights of the user of the Product under the applicable legal provisions.

#### ATTENTION

This card and receipt (or invoice) are necessary to purchase a new panel in case of theft or damage.



The warranty will only be honored in the country in which the unit was originally purchased.

## EXPRESS WARRANTY STATEMENT FOR CAR STEREO AND PERSONAL AUDIO COMPONENTS

JVCKENWOOD AUSTRALIA PTY. LTD. ("JVCKENWOOD") is proud of the quality and workmanship of its audio equipment. This unit has been properly designed, tested and inspected before it was shipped to you. If properly installed and operated in accordance with instructions furnished, it should give optimum reliable performance.

### For Australian Customers

Our goods comes with guarantees that cannot be excluded under the Australian Consumer Law. Under Australian Consumer Law, you are entitled to a replacement or refund for a major failure and for compensation for any other reasonably foreseeable loss or damage. You are also entitled to have the goods repaired or replaced if the goods fail to be of acceptable quality and the failure does not amount to a major failure.

The benefits of this warranty are in addition to any rights and remedies imposed by Australian State and Federal legislation that cannot be excluded. Nothing in this warranty is to be interpreted as excluding, restricting or modifying any State or Federal legislation applicable to the supply of goods and services which cannot be excluded, restricted or modified.

### For New Zealand Customers

The benefits of the express warranty described below are in addition to your statutory rights and remedies under the Consumer Guarantees Act 1993 that cannot be excluded. If you are acquiring Product for the purposes of a business, to the extent permitted by law, the Consumer Guarantees Act 1993 does not apply. Otherwise nothing in this warranty is to be interpreted as excluding, or restricting, the Consumer Guarantees Act 1993. To the extent permitted by law, all other warranties, guarantees or representations (whether implied by statute, common law or custom of the trade or otherwise) in respect of the Product, not expressly included in this warranty, are excluded.

## SCOPE OF EXPRESS WARRANTY

Subject to the "EXCLUSIONS", "PROCEDURE WHEN REQUESTING SERVICE UNDER THE EXPRESS WARRANTY" and "LIMITATIONS" below, each of the KENWOOD brand products ("Products") is expressly warranted under normal installation and use against defects in material and workmanship during the Warranty Period.

This warranty is not transferable to a subsequent customer if the Product is sold by the original purchaser during the Warranty Period. During the Warranty Period, JVCKENWOOD will cause the Product or the defective part of the Product to be repaired by providing to any JVCKENWOOD Authorized Service Centre in Australia or New Zealand (as applicable to country of purchase) free of charge parts necessary to correct any defect in material or workmanship. JVCKENWOOD reserves the right to replace defective parts of the Product with parts and components of similar quality, grade and composition where an identical part or component is not available. Products presented for repair may be replaced by refurbished products of the same type rather than being repaired. Refurbished parts may be used to repair the goods.

## WARRANTY PERIOD

The KENWOOD brand car stereo is expressly warranted for a period of **ONE YEAR** from the date of the original purchase.

## CONDITIONS OF THE EXPRESS WARRANTY

The following are not covered by this express warranty:

1. Voltage conversions;
2. Cabinets, grilles, other exterior finishes, belts, tape heads, and other nondurable parts and accessories;
3. Any fault caused by faulty installation, water damage, the vehicle (including its electronically system) or connection to an incorrect power supply;

4. Periodic check-ups which do not disclose any defects covered by this warranty;
5. Products on which the serial number has been defected, modified or removed;
6. Products that have been subject to abnormal conditions, including environment, temperature, water, fire, humidity, pressure, stress or similar;
7. Alleged defects that are within acceptable industry variances;
8. Damage or deterioration:
  - a. Resulting from installation and/or removal of the product.
  - b. Resulting from accident, misuse, abuse, neglect, unauthorized product modification or failure to follow instructions contained in the Owner's Manual.
  - c. Resulting from installation of parts or accessories that do not conform to the quality or specifications of the original parts or accessories.
  - d. Occurring during shipment (claims must be present to shipper); and
9. Damaged magnetic tapes.

The warranty does not extend to:

1. Installation and removal charges; or
2. Shipping charges to or from an authorised JVCKENWOOD Service Centre.

## PROCEDURE WHEN REQUESTING SERVICE UNDER THE WARRANTY

1. When requesting service under JVCKENWOOD warranty, preferably make your Product available for inspection and testing to the dealer from whom you made the purchase, or to the nearest Authorised JVCKENWOOD Service Centre for KENWOOD products, or ship your Product in its original packaging, or equivalent, with shipping charges and insurance prepaid, to the Authorised JVCKENWOOD Service Centre for KENWOOD products. Otherwise, contact JVCKENWOOD at the contact address listed below.
  - Attach the following to the Product:
    - the warranty record in the back of this page together;
    - a valid purchase docket attached; and
    - detailed description of the problem encountered, including details of any problems which relate to associated equipment.
2. If such inspection and testing find no defect in the Product, the purchaser, at JVCKENWOOD's discretion must pay JVCKENWOOD's cost of service work, evaluation and testing.
3. Make sure you recover this card, your purchase docket and repair docket when accepting the equipment back after repair or after your claim is rejected.

## IMPORTANT NOTICE

1. Proper maintenance and use are important to the performance level of all KENWOOD brand products. Therefore, you should read your instruction manual.
2. Retain your purchase docket together with this warranty record in a safe place, and present them both to prove your eligibility for warranty service.
3. We recommend that you keep all the original packaging as it provide the best protection you can have for transportation of your equipment in the future.
4. Location of nearest JVCKENWOOD Service Centre can be obtained from the dealer.

## LIMITATIONS

To the extent permitted by law, JVCKENWOOD makes no express warranties or representations other than set out in this warranty.

The repair or replacement of the unit or part of the unit is the absolute limits of JVCKENWOOD's liability under this express warranty.

**JVCKENWOOD AUSTRALIA PTY. LTD.**

**4 TALAVERA ROAD, NORTH RYDE**

**N.S.W. 2113, AUSTRALIA**

**TEL. (02) 8879-2211**

**FAX. (02) 8879-2255**

**svcdept@jvckenwood.com.au**

## ATTENTION

This card and receipt (or invoice) are necessary to purchase a new panel in case of theft or damage.