

**KXM**  
**AMPLIFIERS**  
*Owner's Manual*

**KXMA800.8**

Manual del Propietario | **Español**  
AMPLIFICADOR DE LA SERIE KXM.8

Benutzerhandbuch | **Deutsch**  
VERSTÄRKER DER KXM.8-SERIE

Manuel d'utilisation | **Française**  
AMPLIFICATEUR DE SÉRIE KXM.8

**MODEL:**

**KXMA800.8**

### IMPORTANT SAFETY WARNING

PROLONGED CONTINUOUS OPERATION OF AN AMPLIFIER, SPEAKER, OR SUBWOOFER IN A DISTORTED, CLIPPED OR OVER-POWERED MANNER CAN CAUSE YOUR AUDIO SYSTEM TO OVERHEAT, POSSIBLY CATCHING FIRE AND RESULTING IN SERIOUS DAMAGE TO YOUR COMPONENTS AND/OR VEHICLE. AMPLIFIERS REQUIRE UP TO 4 INCHES (10CM) OPEN VENTILATION. SUBWOOFERS SHOULD BE MOUNTED WITH AT LEAST 1 INCH (2.5CM) CLEARANCE BETWEEN THE FRONT OF THE SPEAKER AND ANY SURFACE.



### PERFORMANCE

**Model:**

**KXMA800.8**

RMS Power

@ 14.4V, 4Ω stereo, ≤ 1% THD+N

50 x 8

@ 14.4V, 2Ω stereo, ≤ 1% THD+N

100 x 8

@ 14.4V, 4Ω mono, ≤ 1% THD+N

200 x 4

Length [in, cm]

14-3/4, 37.4

**Specifications common to all models:**

Height [in, cm]

2-1/8, 5.5

Width [in, cm]

8-5/16, 21

Frequency Response [Hz]

10Hz–20kHz

Signal-to-Noise Ratio [dB]

95dB

Input Sensitivity

250mV–10V

Selectable Electronic Crossover

Off; Variable HP, 10–500Hz; Variable LP, 40–500Hz; 400Hz–5,000Hz with 10X Switch (bandpass capable); Slope: 24dB/octave"

KickEQ™ Bass Boost

0–18dB @ 40Hz

### INSTALLATION

**Mounting:** Choose a structurally sound location to mount your KICKER amplifier. Make sure there are no items behind the area where the screws will be driven. Choose a location that allows at least 4" (10cm) of open ventilation for the amplifier. If possible, mount the amplifier in the climate-controlled passenger compartment. Drill four holes using a 7/64" (3mm) bit and use the supplied #8 screws to mount the amplifier.

**Wiring:** The KXM amplifier's RCA inputs will receive either high or low level signals from your car stereo's source unit. A high-level signal can be run from the source unit's speaker outputs to the stereo RCA input on the end panel of the amplifier using the KICKER KISL as shown. Alternatively, the signal can be delivered to the amplifier using the low-level RCA outputs on the source unit. Keep the audio signal cable away from factory wiring harnesses and other power wiring. If you need to cross this wiring, cross it at a 90 degree angle.

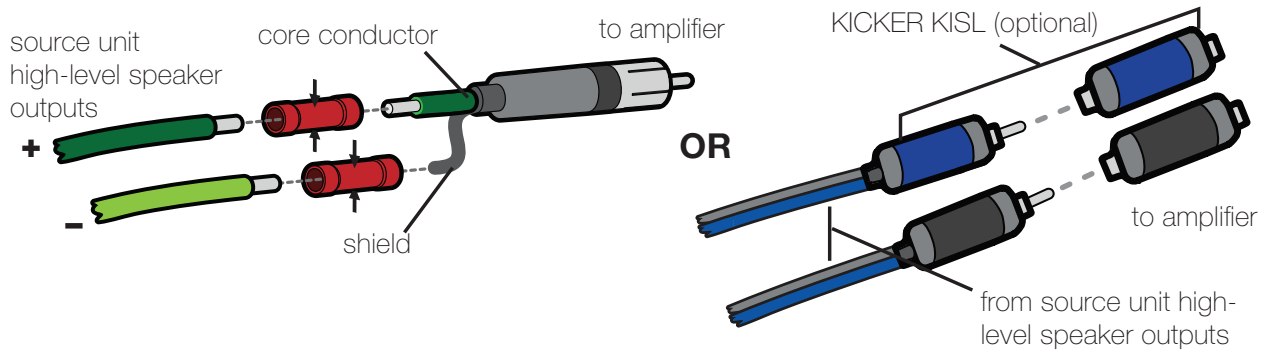

Install a fuse within 7" (18cm) of the battery and in-line with the power cable connected to your amplifier.

<b>Model</b>	<b>External Fuse (sold separately)</b>	<b>Power/Ground Wire</b>	<b>KICKER Wiring Kit</b>
KXMA800.8	1 x 120 Ampere	4 Gauge	PK4, CK4

## POWER WIRING

Amplifier uses 304-stainless steel screws and conformal coated PCB for increased weather resistance

Use the FADER switches to select which inputs are active with respect to their paired output. ON will activate the second input, for example:

If you are using a single RCA pair of inputs, set all FADER switches to OFF.

For any amp section being driven by additional RCA input(s), set the FADER switch(es) to ON.

If you are using all four RCA pairs of inputs, set all FADER switches to ON.

ABYC-compliant power terminals

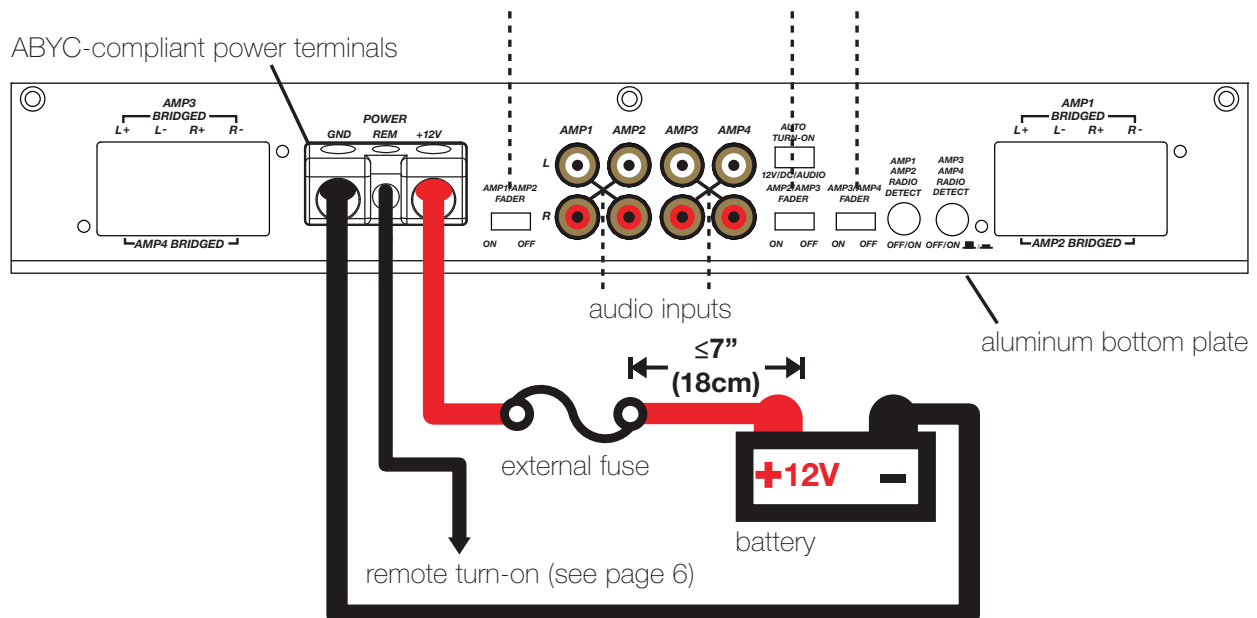

For multiple amplifier installations where distribution blocks are used, each amplifier should have its proper-rated fuse, or breaker, installed between the amplifier and the distribution block within seven inches of the block, or on the distribution block if it provides for fusing. The primary power wire should also be fused between the battery and distribution block, within seven inches of the battery's B+ terminal, with a fuse or breaker rated at least to the sum of the individual amplifier's fuse values, but not to exceed 1.5-times the sum of the individual fuse values (not to exceed the ampacity of the thermal insulation of the wiring as shown in U.S.C.G. CFR33 183.425, Table 5). See the diagram below.

NOTE: Seven inches is the standard distance under U.S. Coast Guard CFR33 for placement of fuses or breakers as required by law for new boat manufacturing. We recommend trying to adhere to this standard in a consumer installation. Failure to do so does not mean you are breaking the law, but it does put the safety of your boat and passengers at risk in the event of a power wire short circuit.

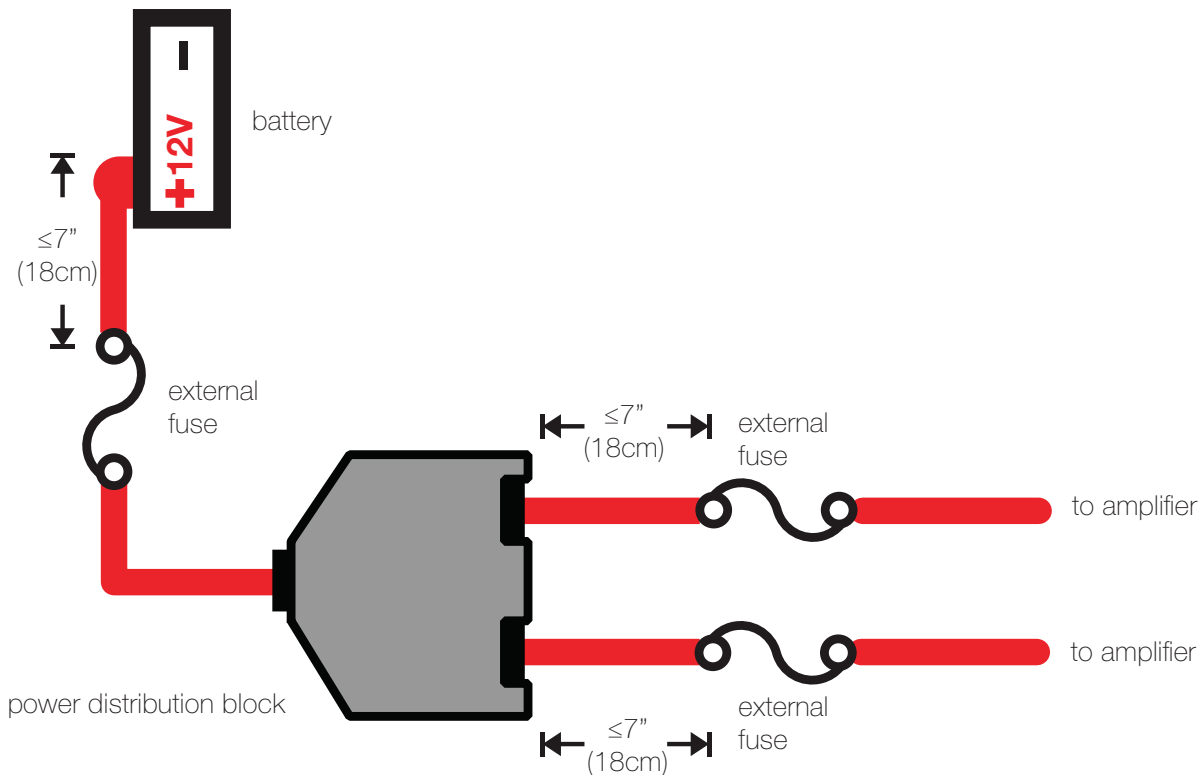

**KICKER will now provide a three-year warranty with all KXA-Series Amplifier purchases paired with a *qualifying* KICKER Installation Kit\* .**

This extends the standard warranty by an additional year. *Amplifier and Kit must be purchased from an **Authorized KICKER Dealer**.*

KICKER KXM amplifier success is currently at an unheard-of rate, making the extended warranty program even more beneficial to you.

Using poor-quality, under-spec wiring kits will impede KXM amplifier performance.

**A superior-quality KICKER installation Kit is guaranteed to extend the life of KXM amplifiers.**

The new extended warranty applies only to KICKER amplifiers and accessories sold to consumers by Authorized KICKER Dealers in the United States of America or its possessions. It also only applies to the original purchaser of KICKER amplifiers and accessories. One warranty extension per amplifier is allowed regardless of the number of amplifier installation kits purchased. This program does not apply to "B"-stock product or factory-refurbished product.

This offer is for a limited time, so see your local Authorized KICKER Dealer soon for details.

**\*U.S.A. Only | EE.UU. solamente | Nur USA | Les USA Seulement**



## EIGHT CHANNEL OPERATION

minimum impedance of 2 ohm

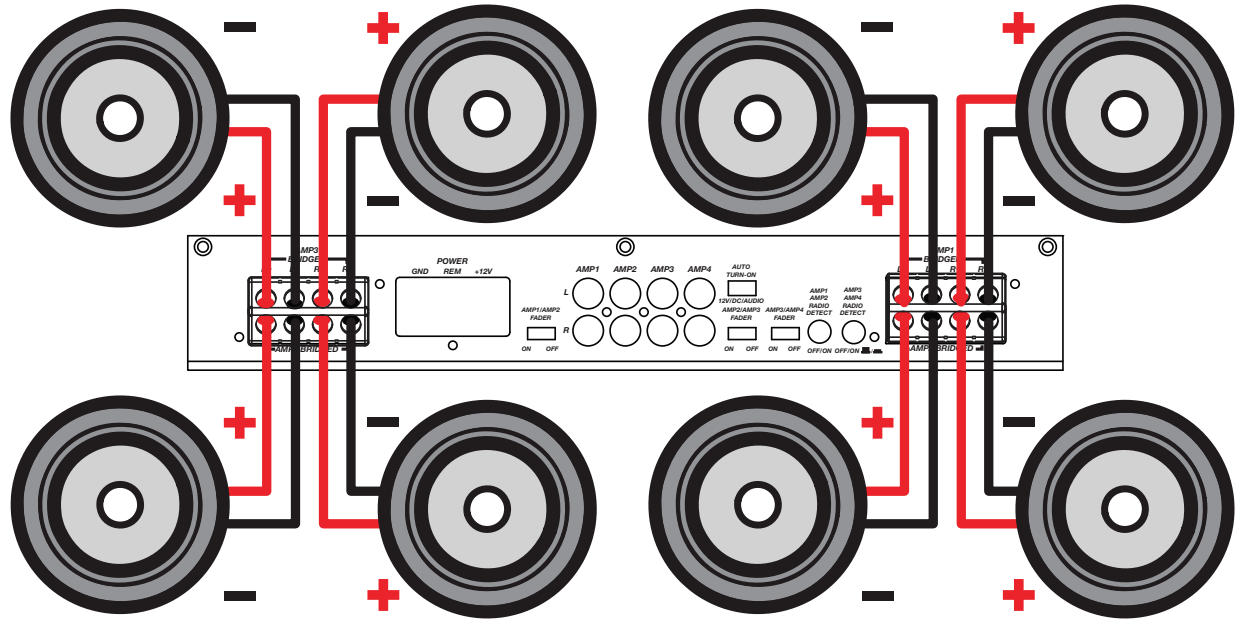

## BRIDGED OPERATION

minimum impedance of 4 ohms

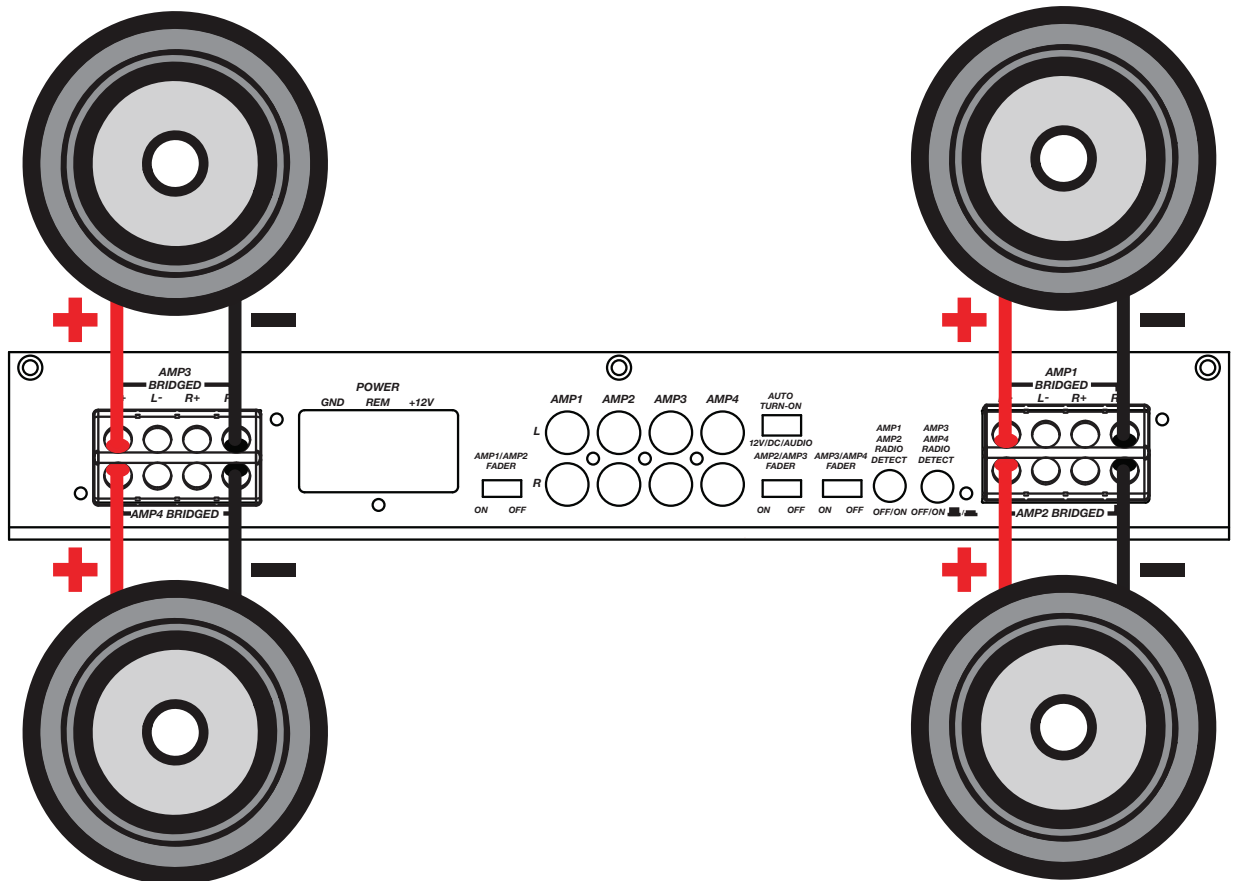

## OPERATION

Mini-USB for internal use only; do NOT remove or tamper. KICKER is not responsible for any damage to equipment resulting from connections made to this port.

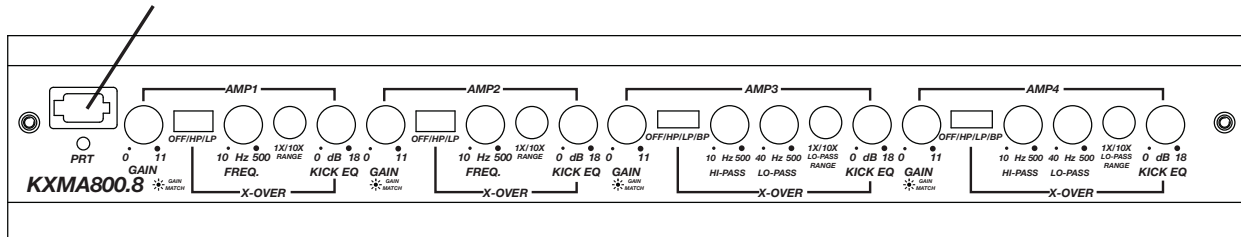

**Automatic Turn-On Selection:** The KXM series offers three different automatic turn-on modes that can be selected on the end panel; +12V, DC Offset, and Audio. Using either the DC Offset or Audio mode causes the REM terminal to have +12V out for turning on additional amplifiers.

- Remote Turn-On: Set the switch to +12V to use the remote turn-on lead from your source unit. Run 18 gauge wire from the Remote Turn-On Lead on your source unit to the terminal labeled REM between the amplifier's positive and negative power terminals. This is the preferred automatic turn-on method.
- DC Offset Turn-On: If Remote Turn-On is not an option, the next best setting is DC Offset. The DC Offset mode detects a 3V DC offset from the HI-Level speaker outputs when the source unit has been turned on.
- Signal Sense Turn-On: The Audio setting is the final alternative for Automatic turn-on. This is a Signal Sense turn-on method that detects the incoming audio signal from your source unit and automatically turns on the amp. This turn-on method will not work properly if the input gain control is not set appropriately.

**Radio Detect:** The RCA inputs on KICKER KXM amplifiers are capable of receiving either Hi or Low-level signals from your source unit. If you are using Hi-Level inputs, but your source unit cannot detect an audio system present or refuses to play audio out of one or more speakers, you may need to set **RADIO DETECT** to **ON**. This will activate a load resistor at the amplifier's inputs and tell the source unit there are speakers present. Do NOT use Radio Detect if you are using a Low-Level input signal; doing so will greatly reduce the input signal.

**Fader Switches:** Turn the Fader switch(es) **OFF** if you are running more than a single pair of RCA inputs to the amplifier. Turn the Fader switch(es) **ON** if you want to drive those channels from a single input. For example, if you are using AMP 1, AMP 2, AMP 3, and AMP 4 RCA inputs, switch the **AMP 1/AMP 2 FADER**, **AMP 2/AMP 3 FADER**, and **AMP 3/AMP 4 FADER** buttons to **OFF**.

**Input Gain Control with Gain Matching:** The input gain control is not a volume control. It matches the output of the source unit to the input level of the amplifier and features Gain Matching to prevent clipping the input. For a quick setup, turn the source unit up to about 3/4 volume (if the source unit goes to 30, turn it to 25). KICKER recommends using the test tones at [www.kicker.com/support/](http://www.kicker.com/support/) to reach the most accurate and best performing settings. Next, slowly turn (clockwise) the gain on the amplifier up until you see the Gain LED light up or hear audible distortion, then turn it down a little. If the **GAIN** knob's backlight comes on, the input is still clipping. For full instructions on Gain Matching, please see the next page.

**Crossover Switches with Frequency Multiplier:** Use the **XOVER** switches on the end panel of the amplifier to set the internal crossovers of AMPS 1 & 2 to **OFF**, **HI-PASS**, **LO-PASS**, or **BAND-PASS** (AMP 2 only). When the switch is set to **OFF**, a full bandwidth signal will be amplified. Set the switch to **HP** if you want the amplifier's internal crossover to serve as a high-pass filter. Set the switch to **LP** if you want the amplifier's internal crossover to serve as a low-pass filter. Set the switch to **BP** when a specific frequency range is required. Never change the crossover switches with the audio system on!

Set the **1X/10X** frequency multiplier switch to the setting that is appropriate for your application. A setting of **10X** will set the range of the **AMP 1** crossover to 100–5,000Hz, and the crossover of **AMP 2** to 100–5,000Hz.

**KICK EQ Bass Boost Control:** The variable bass boost control on the side of the KXMA400.4 amplifier is designed to give you increased output, 0–18dB, at 40Hz. The setting for this control is subjective. If you turn it up, you must readjust the input gain control to avoid clipping the amplifier.

## GAIN MATCHING

In any audio system, the goal is to reach maximum input and output levels without distortion or clipping. The engineers at KICKER have taken the guesswork, and hassle, out of matching the output voltage of your source unit to the amplifier with the Gain Matching feature. To begin, you'll need to download the KICKER test tones from [www.kicker.com/test-tones](http://www.kicker.com/test-tones). The following files are available in MP3 and WAV formats:

1kHz @ 0dBFS, 50Hz @ 0dBFS, 1kHz @ -10dBFS, 50Hz @ -10dBFS, 1kHz @ -5dBFS, 50Hz @ -5dBFS

These test tones are sine waves meant to provide a consistent signal for the KX amplifier to reference. The different recording levels are designed to give you the perfect gain match for your application.

**0dBFS:** Designed for audiophile applications to give you distortion free audio output with the most dynamic range.

**-5dBFS:** Designed for normal/daily applications, there will be less dynamic range but higher potential audio output levels. With this set up you can get some occasional clipping from the amplifier.

**-10dBFS:** Designed only for Subwoofer applications, there will be less dynamic range but higher potential audio output levels. With this set up you can get some clipping from the amplifier.

Afterwards, use the following procedure to accurately Gain Match your amplifier(s):

1. Disconnect the speakers from the KX amplifier.
2. Set all EQ and crossover settings to flat on your source unit.
3. Play the downloadable file from KICKER.com
4. Turn the source unit up to 3/4 volume.
5. Increase the gain of the amplifier until the Gain LED turns on.
6. Decrease the gain of the amplifier until the Gain LED turns off.



All level matching circuitry in the KX amplifiers is at the beginning of the signal chain. If you are going to use features like bass boost, SHOCwave or EQ settings, it may be necessary to readjust the gain to a lower setting to compensate for increased output at those frequencies.

Once the amp and source unit are gain matched, you will want to make certain you are not overdriving your speakers. Use the following procedure:

1. Set the source until volume to 0.
2. Reconnect the speakers to the KX amplifier.
3. Slowly increase the volume level of the source unit as you listen for audible distortion.
4. If you can hear clipping, decrease the gain of the amplifier until it is gone.

Likewise, you can use the CLIP indicator feature of the KXARC remote to easily identify which amplifier's output is clipping and when.

## TROUBLESHOOTING

If your amplifier does not appear to be working, check the obvious things first such as blown fuses, poor or incorrect wiring connections, incorrect setting of crossover switch and gain controls, etc. There is a Protection (PRT) LED on the side panel of your Kicker KXM series amplifier. Depending on the state of the amplifier and the vehicle's charging system, the LED will either glow red or be off.

**Red (PRT) LED flickering with loud music?** The red (PRT) LED indicates low battery voltage. Check all the connections in your vehicle's charging system. It may be necessary to replace or charge your vehicle's battery or replace your vehicle's alternator.

**Red (PRT) LED on, no output?** ❶ Amplifier is very hot = thermal protection is engaged. Test for proper impedance at the speaker terminals with a VOM meter (see the diagrams in this manual for minimum recommended impedance and multiple speaker wiring suggestions). Also check for adequate airflow around the amplifier. ❷ Amplifier shuts down only while vehicle is running = voltage protection circuitry is engaged. Voltage to the amplifier is not within the 10–16 volt operating range. Have the vehicle's charging and electrical system inspected. ❸ Amplifier will only play at low volume levels = short circuit protection is engaged. Check for speaker wires shorted to each other or to the vehicle chassis. Check for damaged speakers or speaker(s) operating below the minimum recommended impedance.

**No or low output?** ❶ Check the balance control on source unit ❷ Check the RCA (or speaker input) and speaker output connections.

**Alternator noise-whining sound with engine's RPM?** ❶ Check for damaged RCA (or speaker input) cable ❷ Check the routing of RCA (or speaker input) cable ❸ Check the source unit for proper grounding ❹ Check the gain settings and turn them down if they are set too high.

**Ground Noise?** KICKER amplifiers are engineered to be fully compatible with all manufacturers' head units. Some head units may require additional grounding to prevent noise from entering the audio signal. If you are experiencing this problem with your head unit, in most cases running a ground wire from the RCA outputs on the head unit to the chassis will remedy this issue.

**CAUTION:** When jump starting the vehicle, be sure that connections made with jumper cables are correct. Improper connections can result in blown amplifier fuses as well as the failure of other critical systems in the vehicle.

If you have more questions about the installation or operation of your new KICKER product, see the Authorized KICKER Dealer where you made your purchase. For more advice on installation, click on the SUPPORT tab on the KICKER homepage, [www.kicker.com](http://www.kicker.com). Choose the TECHNICAL SUPPORT tab, choose the subject you are interested in, and then download or view the corresponding information. Please E-mail [support@kicker.com](mailto:support@kicker.com) or call Technical Services (405) 624-8583 for unanswered or specific questions.



### KXMA800.8

50 x 8 @ 4 ohms, 14.4VDC, 1% THD, CEA-2006B (Watts)  
Signal to Noise Ratio -75dB CEA-2006B (ref: 1W, A-weighted)



## **ELECTRONICS LIMITED WARRANTY**

When purchased from an Authorized KICKER Dealer, KICKER warrants this product to be free from defects in material and workmanship under normal use for a period of TWO (2) YEARS from date of original purchase with receipt. If this product is identified as "Refurbished" or "B Goods", the warranty is limited to a period of THREE (3) MONTHS from the date of original purchase. In all cases you must have the original receipt. Should service be necessary under this warranty for any reason due to manufacturing defect or malfunction during the warranty period, KICKER will repair or replace (at its discretion) the defective merchandise with equivalent merchandise. Warranty replacements may have cosmetic scratches and blemishes. Discontinued products may be replaced with more current equivalent products. This warranty is valid only for the original purchaser and is not extended to owners of the product subsequent to the original purchaser. Any applicable implied warranties are limited in duration to a period of the express warranty as provided herein beginning with the date of the original purchase at retail, and no warranties, whether express or implied, shall apply to this product thereafter. Some states do not allow limitations on implied warranties; therefore, these exclusions may not apply to you. This warranty gives you specific legal rights; however you may have other rights that vary from state to state.

### **WHAT TO DO IF YOU NEED WARRANTY OR SERVICE:**

Defective merchandise should be returned to your local Authorized Stillwater Designs (KICKER) Dealer for warranty service. Assistance in locating an Authorized Dealer can be found at [www.KICKER.com](http://www.KICKER.com) or by contacting Stillwater Designs directly. You can confirm that a dealer is authorized by asking to see a current authorized dealer window decal.

If it becomes necessary for you to return defective merchandise directly to Stillwater Designs (KICKER), call the KICKER Customer Service Department at (405) 624-8510 for a Return Merchandise Authorization (RMA) number. Package only the defective items in a package that will prevent shipping damage, and return to:

**Stillwater Designs, 3100 North Husband St, Stillwater, OK 74075**

The RMA number must be clearly marked on the outside of the package. Please return only defective components. The return of functioning items increases your return freight charges. Non-defective items will be returned freight collect to you. For example, if a subwoofer is defective, only return the defective subwoofer, not the entire enclosure. Include a copy of the original receipt with the purchase date clearly visible, and a "proof-of-purchase" statement listing the Customer's name, Dealer's name and invoice number, and product purchased. Warranty expiration on items without proof-of-purchase will be determined from the type of sale and manufacturing date code. Freight must be prepaid; items sent freight-collect, or COD, will be refused.

### **WHAT IS NOT COVERED?**

This warranty is valid only if the product is used for the purpose for which it was designed. It does not cover:

- o Damage due to improper installation
- o Subsequent damage to other components
- o Damage caused by exposure to moisture, excessive heat, chemical cleaners, and/or UV radiation
- o Damage through negligence, misuse, accident or abuse. Repeated returns for the same damage may be considered abuse
- o Any cost or expense related to the removal or reinstallation of product
- o Speakers damaged due to amplifier clipping or distortion
- o Items previously repaired or modified by any unauthorized repair facility
- o Return shipping on non-defective items
- o Products with tampered or missing barcode labels
- o Products with tampered or missing serial numbers
- o Products returned without a Return Merchandise Authorization (RMA) number
- o Products purchased from an UNAUTHORIZED dealer
- o Freight Damage
- o The cost of shipping product to KICKER
- o Service performed by anyone other than KICKER



### **HOW LONG WILL IT TAKE?**

KICKER strives to maintain a goal of one week turnaround for all electronics (amplifiers, crossovers, equalizers, etc.) returns. Delays may be incurred if lack of replacement inventory or parts is encountered. Failure to follow these steps may void your warranty. Any questions can be directed to the KICKER Customer Service Department at (405) 624-8510. Contact your International KICKER dealer or distributor concerning specific procedures for your country's warranty policies.

**Note:** All specifications and performance figures are subject to change. Please visit [www.KICKER.com](http://www.KICKER.com) for the most current information.

## **INTERNATIONAL WARRANTY**

Contact your International KICKER dealer or distributor concerning specific procedures for your country's warranty policies.

WARNING: KICKER products are capable of producing sound levels that can permanently damage your hearing! Turning up a system to a level that has audible distortion is more damaging to your ears than listening to an undistorted system at the same volume level. The threshold of pain is always an indicator that the sound level is too loud and may permanently damage your hearing. Please use common sense when controlling volume.

Our goods come with guarantees that cannot be excluded under the **Australian Consumer Law**. You are entitled to a replacement or refund for a major failure and for compensation for any other reasonably foreseeable loss or damage. You are also entitled to have the goods repaired or replaced if the goods fail to be of acceptable quality and the failure does not amount to a major failure.

### **GARANTÍA INTERNACIONAL**

### ***Versión Español***

Comuníquese con su concesionario o distribuidor KICKER internacional para obtener información sobre procedimientos específicos relacionados con las normas de garantía de su país.

ADVERTENCIA: Los excitadores KICKER son capaces de producir niveles de sonido que pueden dañar permanentemente el oído. Subir el volumen del sistema hasta un nivel que produzca distorsión es más dañino para el oído que escuchar un sistema sin distorsión al mismo volumen. El dolor es siempre una indicación de que el sonido es muy fuerte y que puede dañar permanentemente el oído. Sea precavido cuando controle el volumen.

La frase "combustible para vivir la vida Livin' Loud™ a todo volumen" se refiere al entusiasmo por la vida que la marca KICKER de estéreos de automóvil representa y a la recomendación a nuestros clientes de que vivan lo mejor posible ("a todo volumen") en todo sentido. La línea de altavoces y amplificadores KICKER es la mejor del mercado de audio de automóviles y por lo tanto representa el "combustible" para vivir a todo volumen en el área de "estéreos de automóvil" de la vida de nuestros clientes. Recomendamos a todos nuestros clientes que obedezcan todas las reglas y reglamentos locales sobre ruido en cuanto a los niveles legales y apropiados de audición fuera del vehículo.

### **INTERNATIONALE GARANTIE**

### ***Deutsche Version***

Nehmen Sie mit Ihren internationalen KICKER-Fachhändler oder Vertrieb Kontakt auf, um Details über die Garantieleistungen in Ihrem Land zu erfahren.

WARNUNG: KICKER-Treiber können einen Schallpegel erzeugen, der zu permanenten Gehörschäden führen kann! Wenn Sie ein System auf einen Pegel stellen, der hörbare Verzerrungen erzeugt, schadet das Ihren Ohren mehr, als ein nicht verzerrtes System auf dem gleichen Lautstärkepegel. Die Schmerzschwelle ist immer eine Anzeige dafür, dass der Schallpegel zu laut ist und zu permanenten Gehörschäden führen kann. Seien Sie bei der Lautstärkeeinstellung bitte vernünftig!

Der Slogan "Treibstoff für Livin' Loud" bezieht sich auf die mit den KICKER-Autostereosystemen assoziierte Lebensfreude und die Tatsache, dass wir unsere Kunden ermutigen, in allen Aspekten ihres Lebens nach dem Besten ("Livin' Loud") zu streben. Die Lautsprecher und Verstärker von KICKER sind auf dem Markt für Auto-Soundsysteme führend und stellen somit den "Treibstoff" für das Autostereoelebnis unserer Kunden dar. Wir empfehlen allen unseren Kunden, sich bezüglich der zugelassenen und passenden Lautstärkepegel außerhalb des Autos an die örtlichen Lärmvorschriften zu halten.

### **GARANTIE INTERNATIONALE**

### ***Versión Française***

Pour connaître les procédures propres à la politique de garantie de votre pays, contactez votre revendeur ou distributeur International KICKER.

AVERTISSEMENT: Les haut-parleurs KICKER ont la capacité de produire des niveaux sonores pouvant endommager l'ouïe de façon irréversible ! L'augmentation du volume d'un système jusqu'à un niveau présentant une distorsion audible endommage davantage l'ouïe que l'écoute d'un système sans distorsion au même volume. Le seuil de la douleur est toujours le signe que le niveau sonore est trop élevé et risque d'endommager l'ouïe de façon irréversible. Réglez le volume en faisant preuve de bon sens!

L'expression "carburant pour vivre plein pot" fait référence au dynamisme de la marque KICKER d'équipements audio pour véhicules et a pour but d'encourager nos clients à faire le maximum ("vivre plein pot") dans tous les aspects de leur vie. Les haut-parleurs et amplificateurs KICKER sont les meilleurs dans le domaine des équipements audio et représentent donc pour nos clients le "carburant pour vivre plein pot" dans l'aspect "installation audio de véhicule" de leur vie. Nous encourageons tous nos clients à respecter toutes les lois et réglementations locales relatives aux niveaux sonores acceptables à l'extérieur des véhicules.



# KXMA800.8 AMPLIFIER | AMPLIFICADOR KXMA800.8 VERSTÄRKER KXMA800.8 | AMPLIFICATEUR KXMA800.8



## Info Card | Tarjeta de Información | Carte Info | Infokarte

Thank you and congratulations on your purchase of the KICKER KXMA Amplifier! The KXMA-series have been engineered to handle the punishing conditions of outdoor and marine audio applications, with UV-treated aluminum chassis, conformal coated PCBs, thick gasketing to seal and protect sensitive electronics, and terminals that meet rigorous ABYC/NMMA standards. Combined with KICKER's audiophile-grade components, DSP features, and signature power, your party on the water or the patio will be as memorable as the music. Incorporate the whole family of KICKER Marine products to maximize your aquatic audio experience!

Sincerely  
Steve Irby  
President/CEO

¡Gracias y enhorabuena por la compra del amplificador KICKER KXMA! La serie KXMA ha sido diseñada para manejar las duras condiciones de las aplicaciones de audio marinas y al aire libre, con chasis de aluminio con tratamiento UV, PCB con revestimiento conformado, juntas gruesas para sellar y proteger componentes electrónicos sensibles y terminales que cumplen con los rigurosos estándares ABYC / NMMA. Combinado con los componentes de grado audiófilo, funciones DSP, y el poder característico de KICKER, su fiesta en el agua o en el patio será tan memorable como la música. ¡Incorpore toda la familia de productos KICKER Marine para maximizar su experiencia de audio acuático!

Atentamente,  
Steve Irby  
Presidente/CEO

Merci et félicitations pour votre achat de l'amplificateur KICKER KXMA! La série KXMA a été conçue pour gérer les conditions difficiles des applications audio extérieures et marines, avec un châssis en aluminium traité aux UV, des circuits imprimés à revêtement conforme, des joints épais pour sceller et protéger les composants électroniques sensibles et des terminaux qui répondent aux normes rigoureuses ABYC / NMMA. Combiné avec les composants de qualité audiophile de KICKER, fonctionnalités DSP, et la puissance de signature, votre fête sur l'eau ou sur la terrasse sera aussi mémorable que la musique. Incorporez toute la famille des produits KICKER Marine pour maximiser votre expérience audio aquatique!

Cordialement,  
Steve Irby  
Président/PDG

Vielen Dank und herzlichen Glückwunsch zum Kauf der KICKER KXMA Verstärkers! Die KXMA-Serie wurde entwickelt, um die strafbaren Bedingungen von Audioanwendungen im Freien und auf See zu bewältigen. Sie verfügt über ein UV-behandeltes Aluminiumgehäuse, konform beschichtete Leiterplatten, eine dicke Dichtung zum Abdichten und Schützen empfindlicher Elektronik sowie Klemmen, die den strengen ABYC / NMMA-Standards entsprechen. In Kombination mit den audiophilen Komponenten, DSP-Funktionen, und der einzigartigen Kraft von KICKER wird Ihre Party auf dem Wasser oder auf der Terrasse so unvergesslich wie die Musik. Integrieren Sie die gesamte Familie der KICKER Marine-Produkte, um Ihr Audioerlebnis im Wasser zu maximieren!

Mit freundlichen Grüßen  
Steve Irby  
President/CEO

Scan here for  
owner's manual  
Escanee aquí para  
manual del Propietario  
Scannen Sie hier nach  
Benutzerhandbuch  
Scannez ici pour  
manuel d'utilisation

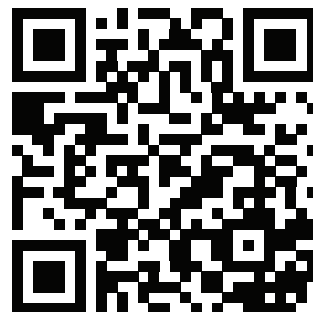

**IMPORTANT:** KICKER recommends a professional installation performed by licensed providers. You are solely responsible for safely mounting and wiring your products. Remember to cap unused wires and avoid electrical shorts!

**IMPORTANTE:** KICKER recomienda que se realice una instalación profesional con proveedores con licencia. Usted es el único responsable por la instalación segura y el cableado de sus productos. ¡Recuerde tapar los cables que no se usen para evitar cortocircuitos eléctricos!

**IMPORTANT :** KICKER recommande une installation professionnelle effectuée par des fournisseurs agréés. Vous êtes l'unique responsable du montage et du câblage de vos produits en toute sécurité. N'oubliez pas de protéger les fils inutilisés et évitez les courts-circuits électriques !

**WICHTIG:** KICKER empfiehlt eine professionelle Montage durch lizenzierte Anbieter. Sie haben die alleinige Verantwortung für die sichere Montage und Verkabelung Ihrer Geräte. Denken Sie daran, ungenutzte Kabel zu verschließen und so Kurzschlüsse zu verhindern!

## Mounting | Montaje | Montage | Befestigung

Choose a dry, structurally sound location to mount your KICKER amplifier. Make sure there are no items behind the area where the screws will be driven. Choose a location that allows at least 4" (10cm) of open ventilation for the amplifier. Drill four holes using a 7/64" (3mm) bit and use the supplied #8 screws to mount the amplifier. Don't drill through the bottom of the boat!

Escoja un lugar estructuralmente sólido para montar el amplificador KICKER. Asegúrese de que no haya nada por detrás de donde van a entrar los tornillos. Escoja un lugar en que queden por lo menos 4 plg. (10 cm) de espacio abierto de ventilación alrededor del amplificador. Si es posible, monte el amplificador en el compartimiento de pasajeros, con ambiente acondicionado. Haga cuatro agujeros con una broca de 7/64 de plg. (3 mm) y monte el amplificador con los tornillos N° 8 que se suministran. ¡No taladre el fondo del barco!

Choisissez un emplacement de structure saine pour monter votre amplificateur KICKER. Assurez-vous que l'arrière de l'emplacement où vous allez enfoncer les vis ne comporte aucun élément. Choisissez un endroit assurant au moins 10 cm (4 po) de dégagement de ventilation ouverte pour l'amplificateur. Si possible, montez l'amplificateur dans l'habitacle passager climatisé. Percez quatre trous à l'aide d'un foret de 3 mm (7/64 po) et utilisez les vis n° 8 fournies pour monter l'amplificateur. Ne percez pas le fond du bateau!

Wählen Sie für die Installation des KICKER-Verstärkers eine strukturell stabile Stelle. Vergewissern Sie sich, dass sich hinter der Einschraubposition der Schrauben nichts befindet. Wählen Sie eine Stelle, die mindestens 10 cm Lüftungsfreiraum für den Verstärker bietet. Installieren Sie, wenn möglich, den Verstärker im klimatisierten Fahrgastraum. Bohren Sie mit einem 3-mm-Bohrer vier Löcher und verwenden Sie die beiliegenden Nr. 8-Schrauben zur Befestigung des Verstärkers. Bohren Sie nicht durch den Boden des Bootes!

# Wiring | Cabelado | Câblage | Verkabelung

See owner's manual for information on how to use amplifier features such as gain, crossover, bass boost and more!

Consulte el manual del propietario para obtener información sobre cómo utilizar las funciones del amplificador, como ganancia, crossover, refuerzo de graves y más.

Consultez le manuel de l'utilisateur pour plus d'informations sur l'utilisation des fonctions de l'amplificateur telles que le gain, le crossover, l'amplification des basses et plus encore!

Informationen zur Verwendung von Verstärkerfunktionen wie Gain, Crossover, Bass Boost und mehr finden Sie in der Bedienungsanleitung!

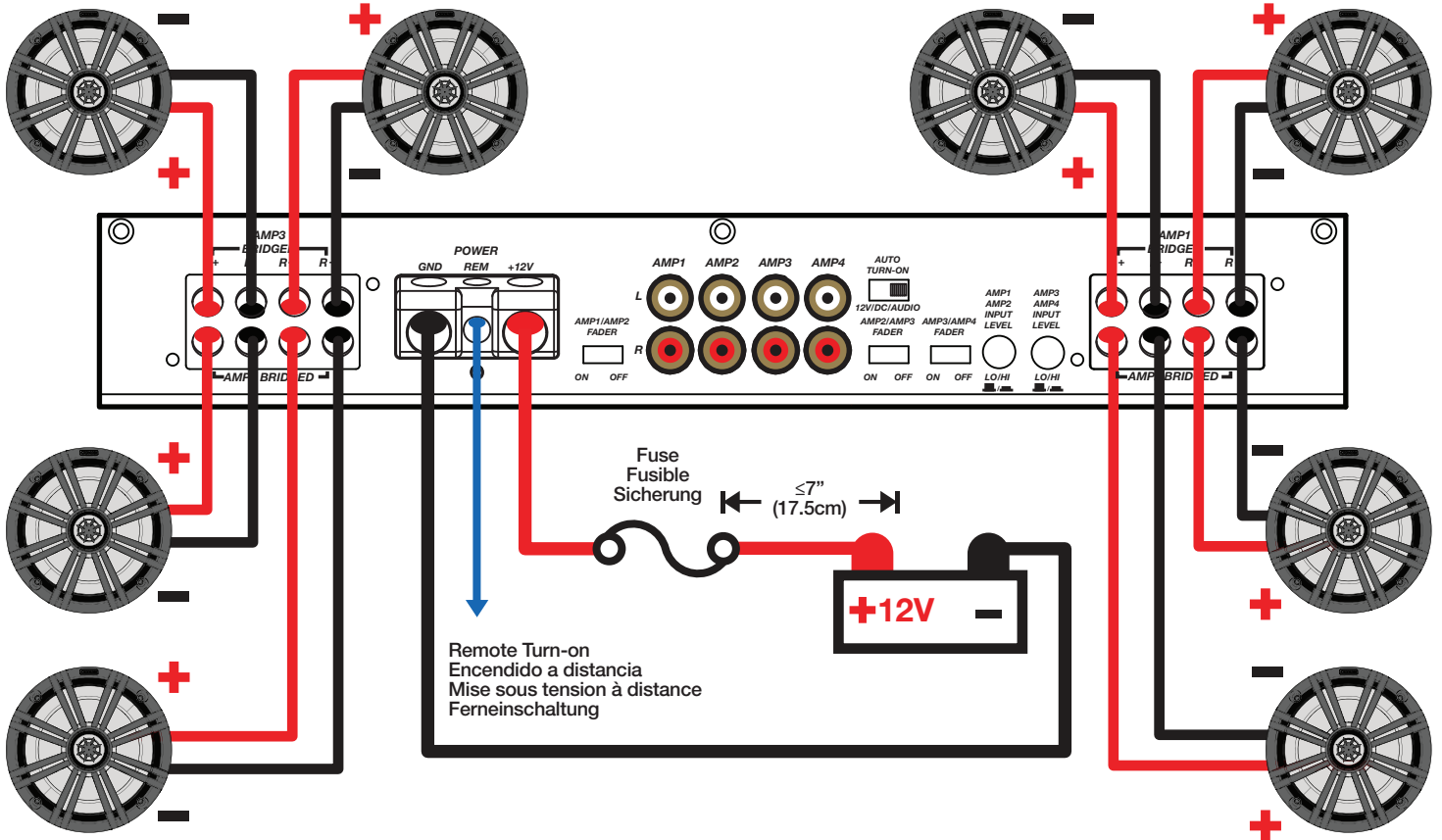

Model	External Fuse (sold separately)	Power/ Ground Wire	KICKER Wiring Kit
KXMA800.8	1 x 125 Ampere	4 Gauge	KMPK4, PK4, CK4

Modelo	Fusible Externo (no incluido)	Cable de Alimentación y Conexión a Tierra	Kit de cableado KICKER
KXMA800.8	1 x 125 Ampere	Calibre 4	KMPK4, PK4, CK4

Modèle	Fusible Externe (non inclus)	Fil de Masse / Alimentation	KICKER Kit de câblage
KXMA800.8	1 x 125 Ampères	Calibre 4	KMPK4, PK4, CK4

Modell	Externe Sicherung (nicht inbegriffen)	Massekabel	KICKER Verkabelungssatz
KXMA800.8	1 x 125 Ampere	4 GA	KMPK4, PK4, CK4

