

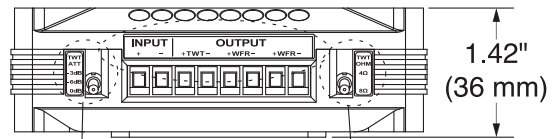

PUNCH™

Pro Crossover

PP4-X / PP8-X

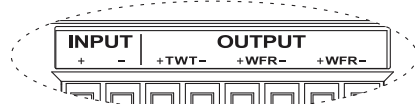
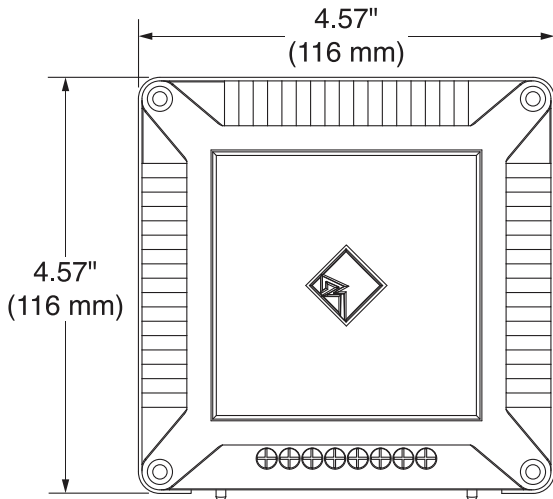

Tweeter
Attenuation

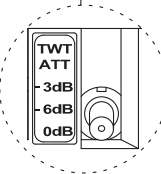

Tweeter
Impedance

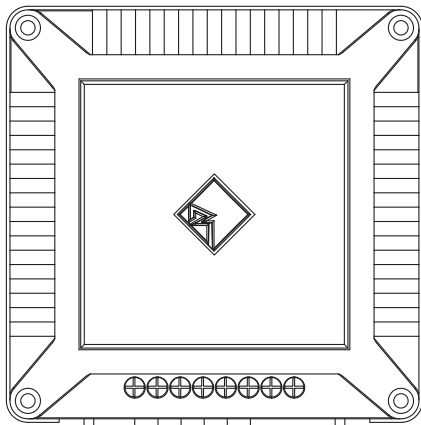
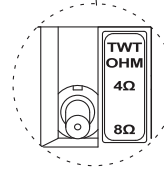

AMP

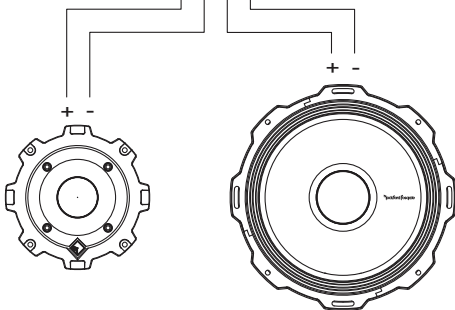

PP4-T or PP8-T
(ADJUST Impedance
switch on crossover
accordingly)

PP4-X compatible with
RF PRO 4ohm mids
PP8-X compatible with
RF PRO 8ohm mids

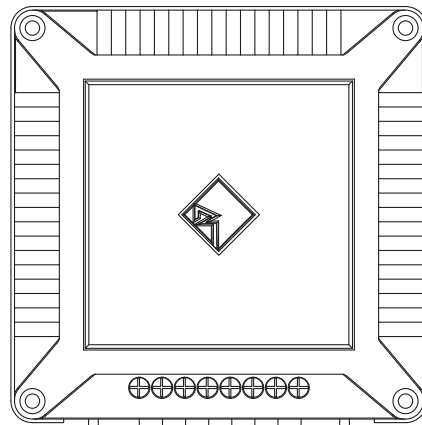

AMP

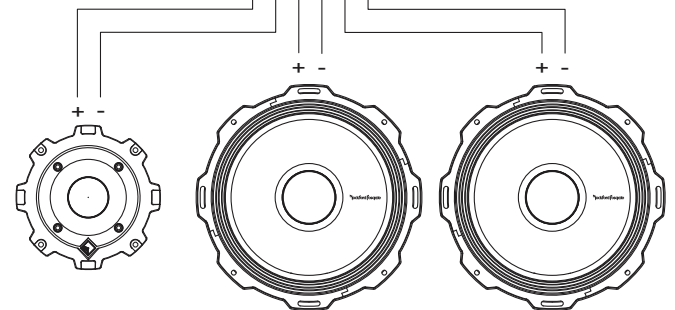

PP4-T or PP8-T
(ADJUST Impedance
switch on crossover
accordingly)

PP4-X compatible with
RF PRO 4ohm mids
PP8-X compatible with
RF PRO 8ohm mids

Example wiring diagram.

**(4) x PP8-T Tweeters
wired
with (2)x PP4-6**

**Ensure pro crossover impedance switch
is set to match the final combined tweeter
impedance, either 4ohm or 8ohm**

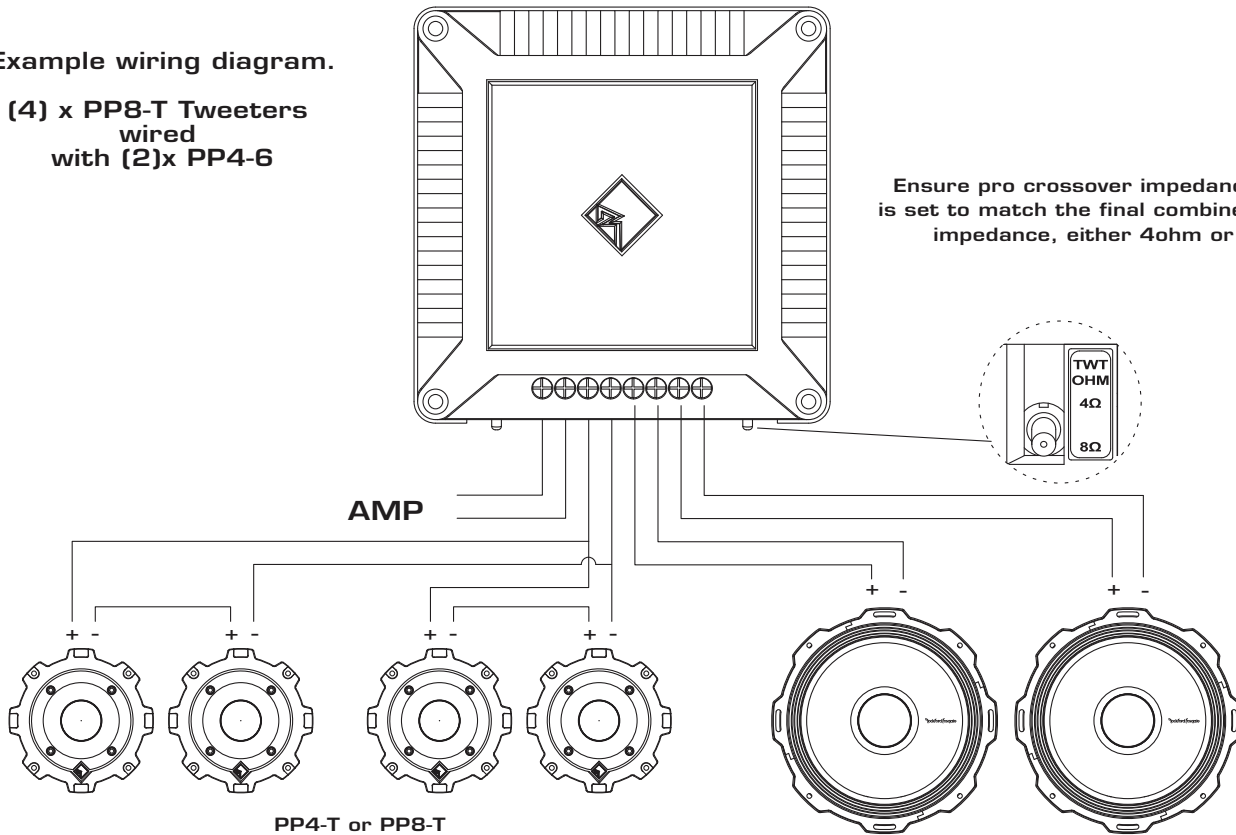

PP4-T or PP8-T

**PRO crossover is compatible with multiple wiring configurations
and multiple tweeters / drivers.**

**PP4-X compatible with
RF PRO 4ohm mids
PP8-X compatible with
RF PRO 8ohm mids**

LIMITED WARRANTY STATEMENT

Rockford Corporation offers a limited warranty on Rockford Fosgate products on the following terms:

Length of Warranty

Speakers – 1 Year. Any Factory Refurbished Product – 90 days (receipt required)

What is Covered

This warranty applies only to Rockford Fosgate products sold to consumers by Authorized Rockford Fosgate Dealers in the United States of America or its possessions. Product purchased by consumers from an Authorized Rockford Fosgate Dealer in another country are covered only by that country's Distributor and not by Rockford Corporation.

Who is Covered

This warranty covers only the original purchaser of Rockford product purchased from an Authorized Rockford Fosgate Dealer in the United States. In order to receive service, the purchaser must provide Rockford with a copy of the receipt stating the customer name, dealer name, product purchased and date of purchase. Products found to be defective during the warranty period will be repaired or replaced (with a product deemed to be equivalent) at Rockford's discretion.

What is Not Covered

- 1. Damage caused by accident, abuse, improper operations, water, theft, shipping
- 2. Any cost or expense related to the removal or reinstallation of product
- 3. Service performed by anyone other than Rockford or an Authorized Rockford Fosgate Service Center
- 4. Any product which has had the serial number defaced, altered, or removed
- 5. Subsequent damage to other components
- 6. Any product purchased outside the U.S.
- 7. Any product not purchased from an Authorized Rockford Fosgate Dealer

Limit on Implied Warranties

Any implied warranties including warranties of fitness for use and merchantability are limited in duration to the period of the express warranty set forth above. Some states do not allow limitations on the length of an implied warranty, so this limitation may not apply. No person is authorized to assume for Rockford Fosgate any other liability in connection with the sale of the product.

How to Obtain Service

Contact the Authorized Rockford Fosgate Dealer you purchased this product from. If you need further assistance, call 1-800-669-9899 for Rockford Customer Service. You must obtain an **RA# (Return Authorization number)** to return any product to Rockford. You are responsible for shipment of product to Rockford.

EU Warranty

This product meets the current EU warranty requirements, see your Authorized dealer for details.



Rockford Fosgate
Rockford Corporation
600 South Rockford Drive
Tempe, Arizona 85281 U.S.A.
In U.S.A., (480) 967-3565
Customer Service 1-800-669-9899
www.rockfordfosgate.com

©2012 Rockford Corporation. All rights reserved.
Rockford Fosgate and the Rockford Fosgate logo are either registered trademarks or trademarks of Rockford Corporation.

