

# Jeep Wrangler

## SBV-10-WRA

### Pre-loaded 10" Subwoofer System

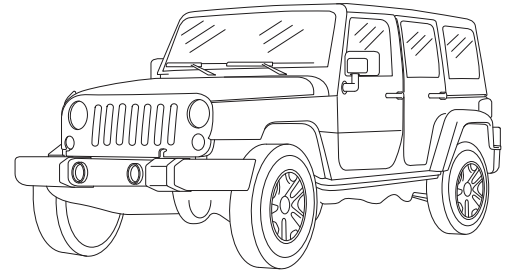

**Installation Manual**  
**Model: 4-Door Wrangler Unlimited**  
**Year: 2007-2018 JKU**

\* The specified vehicles have been tested and have met compatibility specs at the time of testing. Compatibility is not guaranteed if the manufacturer has made production changes to the listed vehicles above.



Mandatory

**Disconnect the battery before beginning the installation.**  
**Failure to do so can lead to electric shock, injury or damage to equipment.**

## Introduction

Congratulations on purchasing the SBV-10-WRA. This installation manual is designed to take you through the step-by-step installation of the SBV-10-WRA into a 2007 - 2018 Jeep Wrangler Unlimited. Please familiarize yourself with the owners manual and if you still have additional questions please call 1-800-TECH-101.



## Note

- Design and specifications are subject to change without notice for improvement.





## To Ensure Safe Use, Always Follow These Precautions

- The installation of this product requires specialized skills and experience. We recommend that you have the product installed by an Alpine authorized dealer.
- Before you use this product, be sure to carefully read this installation manual and the separate user's manual so that you can use the product correctly. Alpine Electronics bears no responsibility for problems that arise as a result of failure to follow the instructions in the manuals.
- This manual includes a number of symbols that are intended to help you use the product safely, to prevent harm to you and others, and to protect against damage to property. These symbols and their meanings are listed below. Make sure you fully understand these symbols before you begin reading the main text.

## Explanations of Injury and Damage That May Result from Incorrect Use

 <b>Warning</b>	Ignoring the content marked by this indication and using the product incorrectly may lead to death or serious injury.
 <b>Caution</b>	Ignoring the content marked by this indication and using the product incorrectly may lead to injury or property damage.



**Types of Precautions**

 Forbidden	Indicates actions that are forbidden (must not be performed)
 Forbidden	Indicates that disassembly is forbidden.
 Mandatory	Indicates actions that are mandatory (must be performed)
 Warning	Marks content that should receive your full attention.

 **Warning**

**Do not disassemble or modify the product. Doing so could lead to an accident, fire, or electric shock.**  Forbidden

**Store screws and other small objects where small children cannot reach them. If one of these small objects is swallowed, consult with a doctor immediately.** 

**When replacing fuses, be sure to use fuses with the specified current rating. Failing to do so could lead to an accident or fire.**   Forbidden Mandatory

**Only connect the product to a 12 VDC negative ground car. Failing to do so could lead to an accident or fire.**  Mandatory

**Before you begin wiring, remove the ground wire from the negative terminal of the battery. Failing to do so could lead to electric shock or injury.** 

**Do not cut the insulation on a cord and take power from another device. Doing so could lead to fire or electric shock.**  Forbidden

**Do not install the product in a location where it will obstruct the driver's forward view; interfere with the operation of the steering wheel, gearshift, or the like; or pose a threat to passengers. Doing so could lead to an accident or injury.**  Forbidden

**When making a hole in the vehicle body, be careful to avoid damaging pipes, the fuel tank, electrical wiring, and the like. This kind of damage could lead to an accident or fire.** 

**When installing and grounding the product, do not use any of the bolts or nuts of the steering wheel, brakes, fuel tank, or the like. Doing so could make the brakes stop working or lead to fire.**  Forbidden

**Do not install the product near the passenger-side airbag. Doing so could interfere with the operation of the airbag and lead to an accident or injury.**  Forbidden

**Bundle cords so that they don't interfere with driving. Wrapping cords around the steering wheel, gearshift, brake pedal, or the like, could lead to an accident or damage equipment.** 

 **Caution**

**Connect the product properly according to the instructions. Failing to do so could lead to fire or an accident.**  Forbidden

**Do not sandwich cords between the seat railing or allow them to touch protrusions. Resulting breaks or shorts could lead to electric shock or fire.** 





**Do not block vents or heat sinks. Doing so could lead to fire or damage equipment.** 

**Use the accessories according to the instructions, and attach them securely. Failing to do so could lead to an accident or damage equipment.**  Forbidden

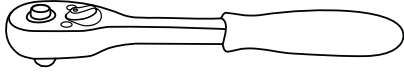
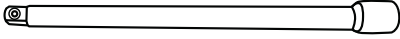

**Do not install the product where it may be exposed to water or in a place with high levels of humidity or dust. Doing so could lead to fire or damage equipment.**  Forbidden

**The installation and wiring of this product requires specialized skills and experience. Have the product installed by an Alpine authorized dealer.** 

**Tools Required**

Ratchet	Extension
	
Torx Bits	18mm Socket
 T30  T45	

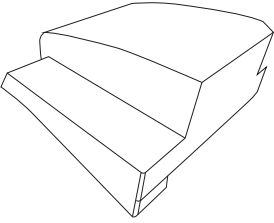
**Accessory List**

Speaker Connector	Subwoofer Enclosure	Manual
		

## Passenger Seat Removal

- Using an 18mm socket, extract the (4) seat bolts from the passenger side seat. Save seat bolts for later.

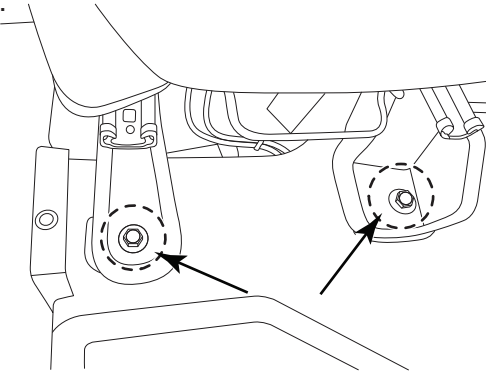

Front view

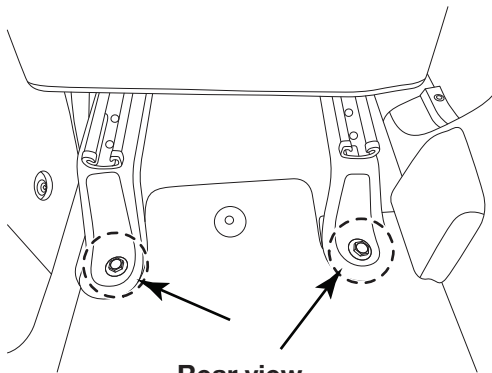

Rear view

- Using a T45 Torx extract (1) bolt from the seat belt anchor.

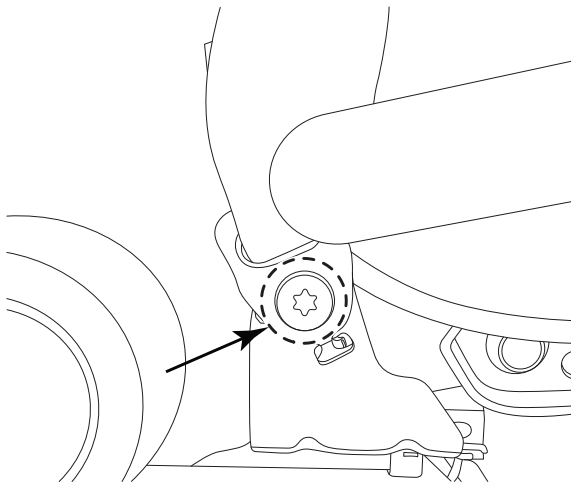

**⚠ Disconnect the battery before continuing**

- Disconnect the two connectors from the seat base. May vary depending on the trim.

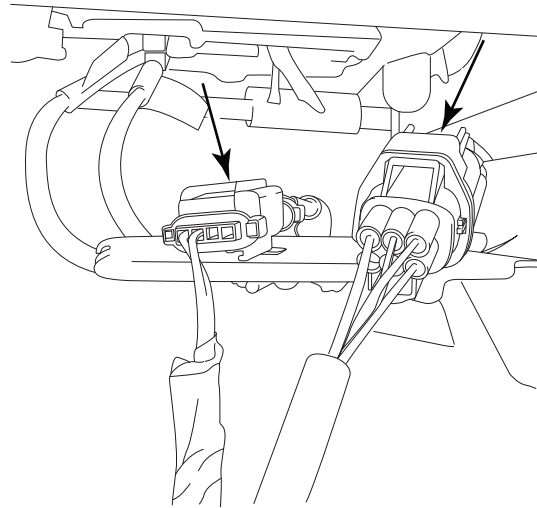

- Position the seat in a secure manner to gain access to the bottom of the seat. Using a T30 Torx, remove the OEM harness mounting plate as shown below. Use a panel removal tool to remove the two plugs from the mounting plate.

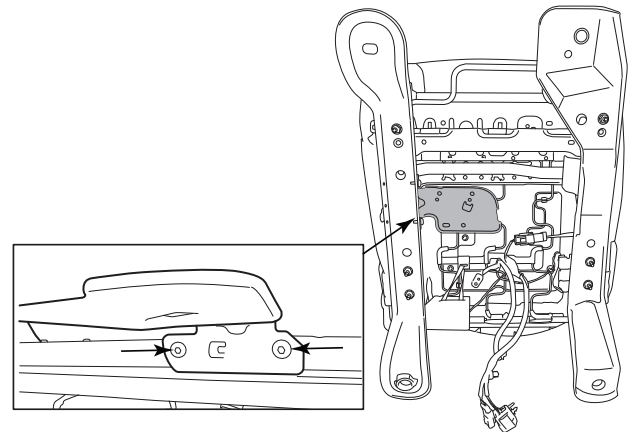

**⚠ Use caution when removing the seat.**

- Secure the connector plugs to the left side of the seat as shown below.

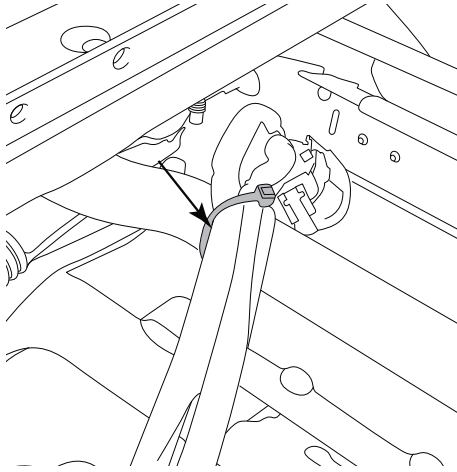

## Enclosure Installation

- Place subwoofer enclosure on the seat floor and connect the speaker connector to the enclosure.

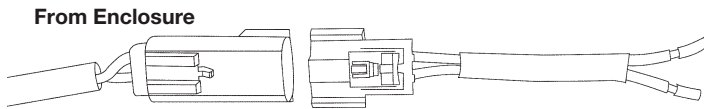

Connect speaker connector to an amplifier (not included)

 **Observe speaker polarity when connecting to the speaker connector.**

 **Ensure wires are not pinched or interfere with any safety equipment.**

- Carefully position the passenger seat over the enclosure while carefully aligning the enclosure in between the seats brackets. Observe the direction of the enclosure. Secure using the 18mm seat bolts (4) as shown below.



**Tighten the seat bolts to 55 ft lbs**

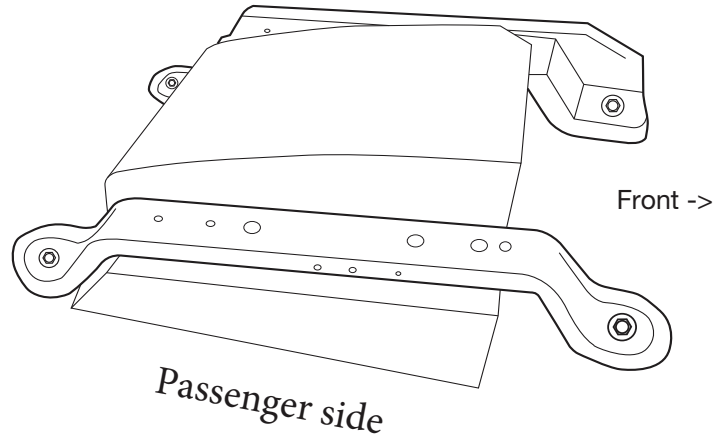

- Re-attach the seat belt anchor using the T45 Torx bolt. Reconnect the two plugs under the seat.

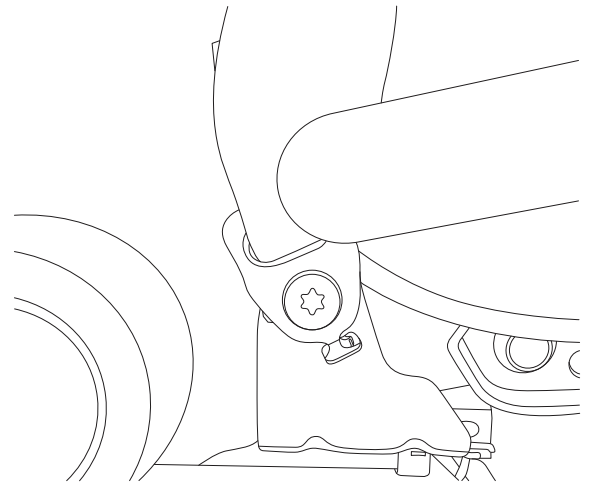

**Tighten the seatbelt bolts to 30 ft lbs**

- Reconnect the battery terminals.

---

## Specifications

---

<b>Subwoofer</b>	10" High Performance Transducer
<b>Impedance</b>	2ohm
<b>Power Handling</b>	300W RMS
<b>Frequency Response</b>	35 - 200Hz (-6dB)
<b>Water Resistance</b>	IP66 Rating
<b>Connector/Cables</b>	2-pin / 12ga.
<b>Size</b>	16-1/4" (L) x 15-3/4" (W) x 8-3/8" (H) 41.2cm (L) x 40.0 cm (W) x 21.2 cm(H)
<b>Weight</b>	18lbs. (8.2 kg.)

---

## Important Information

---

Your listening satisfaction is important to us. In order to maximize and maintain peak speaker performance the following guidelines are being provided. Please read this notice carefully before operating the speakers.

1. Do not over-drive the amplifier. Over-driving the amplifier will result in distortion or clipping and can damage any speaker.
2. Make sure gain controls are properly set (Follow instructions in amplifier owner's manual).
3. Make sure that the speaker is properly rated for the amplifier.
4. Make sure that volume, bass, treble, equalization or crossover settings do not cause the amplifier to over-drive.

Failure to follow these guidelines may result in burned or damaged speaker voice coils which will void your warranty.

If further assistance is necessary, please contact your Alpine authorized dealer.



## LIMITED WARRANTY

ALPINE ELECTRONICS OF AMERICA, INC. ("Alpine"), is dedicated to quality craftsmanship and is pleased to offer this Warranty. We suggest that you read it thoroughly. Should you have any questions, please contact your Dealer or contact Alpine at one of the telephone numbers listed below.

### ●PRODUCTS COVERED:

This Warranty covers Car Audio Products and Related Accessories ("the product"). Products purchased in the Canada are covered only in the Canada. Products purchased in the U.S.A. are covered only in the U.S.A.

### ●LENGTH OF WARRANTY:

This Warranty is in effect for three years from the date of the first consumer purchase.

### ●WHO IS COVERED:

This Warranty only covers the original purchaser of the product, who must reside in the United States, Puerto Rico or Canada.

### ●WHAT IS COVERED:

This Warranty covers defects in materials or workmanship (parts and labor) in the product.

### ●WHAT IS NOT COVERED:

This Warranty does not cover the following:

- ① Damage occurring during shipment of the product to Alpine for repair (claims must be presented to the carrier).
- ② Damage caused by accident or abuse, including burned voice coils caused by over-driving the speaker (amplifier level is turned up and driven into distortion or clipping). Speaker mechanical failure (e.g. punctures, tears or rips). Cracked or damaged LCD panels. Dropped or damaged hard drives.
- ③ Damage caused by negligence, misuse, improper operation or failure to follow instructions contained in the Owner's manual.
- ④ Damage caused by act of God, including without limitation, earthquake, fire, flood, storms or other acts of nature. Any cost or expense related to the removal or reinstallation of the product.
- ⑤ Service performed by an unauthorized person, company or association.
- ⑥ Any product which has the serial number defaced, altered or removed.
- ⑦ Any product which has been adjusted, altered or modified without Alpine's consent.
- ⑧ Any product not distributed by Alpine within the United States, Puerto Rico or Canada.
- ⑨ **Any product not purchased from an Authorized Alpine Dealer.**

### ●HOW TO OBTAIN WARRANTY SERVICE:

- ① You are responsible for delivery of the product to an Authorized Alpine Service Center or Alpine for repair and for payment of any initial shipping charges. Alpine will, at its option, repair or replace the product with a new or reconditioned product without charge. If the repairs are covered by the warranty, and if the product was shipped to an Authorized Alpine Service Center or Alpine, Alpine will pay the return shipping charges.
- ② You should provide a detailed description of the problem(s) for which service is required.
- ③ You must supply proof of your purchase of the product.

- ④ You must package the product securely to avoid damage during shipment. To prevent lost packages it is recommended to use a carrier that provides a tracking service.

### ●HOW WE LIMIT IMPLIED WARRANTIES:

ANY IMPLIED WARRANTIES INCLUDING FITNESS FOR USE AND MERCHANTABILITY ARE LIMITED IN DURATION TO THE PERIOD OF THE EXPRESS WARRANTY SET FORTH ABOVE AND NO PERSON IS AUTHORIZED TO ASSUME FOR ALPINE ANY OTHER LIABILITY IN CONNECTION WITH THE SALE OF THE PRODUCT.

### ●HOW WE EXCLUDE CERTAIN DAMAGES:

ALPINE EXPRESSLY DISCLAIMS LIABILITY FOR INCIDENTAL AND CONSEQUENTIAL DAMAGES CAUSED BY THE PRODUCT. THE TERM "INCIDENTAL DAMAGES" REFERS TO EXPENSES OF TRANSPORTING THE PRODUCT TO THE ALPINE SERVICE CENTER, LOSS OF THE ORIGINAL PURCHASER'S TIME, LOSS OF THE USE OF THE PRODUCT, BUS FARES, CAR RENTALS OR OTHER COSTS RELATING TO THE CARE AND CUSTODY OF THE PRODUCT. THE TERM "CONSEQUENTIAL DAMAGES" REFERS TO THE COST OF REPAIRING OR REPLACING OTHER PROPERTY WHICH IS DAMAGED WHEN THIS PRODUCT DOES NOT WORK PROPERLY. THE REMEDIES PROVIDED UNDER THIS WARRANTY ARE EXCLUSIVE AND IN LIEU OF ALL OTHERS.

### ●HOW STATE/PROVINCIAL LAW RELATES TO THE WARRANTY:

This Warranty gives you specific legal rights, and you may also have other rights which vary from state to state and province to province. In addition, some states/provinces do not allow limitations on how long an implied warranty lasts, and some do not allow the exclusion or limitation of incidental or consequential damages. Accordingly, limitations as to these matters contained herein may not apply to you.

### ●IN CANADA ONLY:

This Warranty is not valid unless your Alpine car audio product has been installed in your vehicle by an Authorized Installation Center, and this warranty stamped upon installation by the installation center.

### ●HOW TO CONTACT CUSTOMER SERVICE:

Should the product require service, please call the following number for your nearest Authorized Alpine Service Center.

<b>CUSTOMER SERVICE</b> 1-800-421-2284, ext. 860307
<b>TECH SUPPORT</b> 1-800-TECH-101 (1-800-832-4101)

Or visit our website at; <http://www.alpine-usa.com>

ALPINE ELECTRONICS OF AMERICA, INC., 19145 Gramercy Place, Torrance, California 90501, U.S.A.

**Do not send products to this address.**

Call the toll free telephone number or visit the website to locate a service center.





## GARANTIE LIMITÉE

Fidèle à son engagement de ne fournir que des produits de qualité, ALPINE ELECTRONICS OF AMERICA, INC. («Alpine») est heureuse de vous offrir cette garantie. Nous vous suggérons de le lire attentivement et en entier. Si vous avez la moindre question, veuillez contacter l'un de nos concessionnaires ou appeler directement Alpine aux numéros listés ci-dessous.

### ● PRODUITS COUVERTS PAR LA GARANTIE:

Cette garantie couvre les produits audio/visuel de voiture et les accessoires connexes ("le produit"). Elle ne couvre les produits que dans le pays où ils ont été achetés.

### ● DURÉE DE LA GARANTIE

Cette garantie d'une durée de trois ans entre en vigueur le jour où le consommateur achète le produit.

### ● PERSONNES PROTÉGÉES PAR LA GARANTIE

Seul l'acheteur original du produit, s'il réside aux États-Unis, à Porto Rico ou au Canada, peut se prévaloir de la garantie.

### ● CE QUI EST COUVERT

Cette garantie couvre tous les défauts de matériaux et de fabrication (pièces et main d'œuvre) du produit.

### ● CE QUI N'EST PAS COUVERT

Cette garantie ne couvre pas ce qui suit:

- ① Les dommages survenus durant le transport des produits renvoyés à Alpine pour être réparés (les réclamations doivent être adressées au transporteur);
- ② Les dégâts provoqués par un accident ou une mauvaise utilisation, y compris des bobines acoustiques grillées suite à une surexcitation des enceintes (augmentation du niveau de l'amplificateur jusqu'à atteindre un effet de distorsion ou d'écrêtage), une défaillance mécanique des enceintes (perforations, déchirures ou fentes), panneaux LCD fissurés ou endommagés, disques durs endommagés ou ayant subi une chute.
- ③ Les dommages dus à la force majeure, notamment aux tremblements de terre, au feu, aux inondations, aux tempêtes ou aux autres cataclysmes naturels;
- ④ Les frais ou les dépenses relatifs à l'enlèvement ou à la réinstallation du produit;
- ⑤ Les services rendus par une personne, physique ou morale non autorisée;
- ⑥ Les produits dont le numéro de série a été effacé, modifié ou retiré;
- ⑦ Les produits qui ont été adaptés ou modifiés sans le consentement d'Alpine;
- ⑧ Les produits qui ne sont pas distribués par Alpine aux États-Unis, à Porto Rico ou au Canada;
- ⑨ **Les produits qui n'ont pas été achetés par l'entremise d'un concessionnaire Alpine autorisé;**

### ● COMMENT SE PRÉVALOIR DE LA GARANTIE

- ① Il vous faut remettre le produit nécessitant des réparations à un centre de service autorisé Alpine ou à Alpine même et en assumer les frais de transport. Alpine a le choix entre réparer le produit ou le remplacer par un produit neuf ou révisé, le tout sans frais pour vous. Si les réparations sont couvertes par la garantie et si le produit a été envoyé à un centre de service Alpine ou à Alpine, le paiement des frais de réexpédition du produit incombe Alpine.
- ② Vous devez donner une description détaillée des problèmes qui sont à l'origine de votre demande de réparation.
- ③ Vous devez joindre la preuve de votre achat du produit.
- ④ Vous devez emballer soigneusement le produit pour éviter tout dommage durant son transport. Pour éviter la perte de l'envoi, il est conseillé de choisir un transporteur qui propose un service de suivi des envois.

### ● LIMITATION DES GARANTIES TACITES

LA DURÉE DE TOUTES LES GARANTIES TACITES, Y COMPRIS LA GARANTIE D'ADAPTATION À L'UTILISATION ET LA GARANTIE DE QUALITÉ LOYALE ET MARCHANDE, EST LIMITÉE À CELLE DE LA GARANTIE EXPRESSE DÉTERMINÉE CI-DESSUS. PERSONNE N'EST AUTORISÉ À ENGAGER AUTREMENT LA RESPONSABILITÉ D'ALPINE EN VERTU DE LA VENTE D'UN PRODUIT.

### ● EXCLUSIONS DE LA GARANTIE

ALPINE STIPULE EXPRESSÉMENT QU'ELLE N'EST PAS RESPONSABLE DES DOMMAGES-INTÉRÊTS ET DOMMAGES INDIRECTS PROVOQUÉS PAR LE PRODUIT. LES DOMMAGES-INTÉRÊTS SONT LES FRAIS DE TRANSPORT DU PRODUIT VERS UN CENTRE DE SERVICE ALPINE, LA PERTE DE TEMPS DE L'ACHETEUR ORIGINAL, LA PERTE D'UTILISATION DU PRODUIT, LES BILLETS D'AUTOBUS, LA LOCATION DE VOITURES ET TOUS LES AUTRES FRAIS LIÉS À LA GARDE DU PRODUIT. LES DOMMAGES INDIRECTS SONT LES FRAIS DE RÉPARATION OU DE REMPLACEMENT D'AUTRES BIENS ENDOMMAGÉS SUITE AU MAUVAIS FONCTIONNEMENT DU PRODUIT. LES RECOURS PRÉVUS PAR LES PRÉSENTES EXCLUENT ET REMPLACENT TOUTE AUTRE FORME DE RECOURS.

### ● LIEN ENTRE LA GARANTIE ET LA LOI

La garantie vous donne des droits spécifiques, mais vous pouvez aussi jouir d'autres droits, qui varient d'un état ou d'une province à l'autre. En outre, certains états et certaines provinces interdisent de limiter la durée des garanties tacites ou d'exclure les dommages accessoires ou indirects. Dans ce cas, les limites et les exclusions de la garantie peuvent ne pas s'appliquer à vous.

### ● CLAUSE APPLICABLE AU CANADA SEULEMENT

Pour que la garantie soit valable, il faut qu'un centre d'installation autorisé ait installé le système audio pour l'auto dans votre véhicule et qu'il ait ensuite apposé son cachet sur la garantie.

### ● NUMÉROS D'APPEL DU SERVICE À LA CLIENTÈLE

Si vous avez besoin de nos services, veuillez appeler Alpine aux numéros ci-dessous pour le centre de service autorisé Alpine le plus proche.

**SERVICE À LA CLIENTÈLE 1-800-421-2284, poste 860307  
ASSISTANCE TECHNIQUE 1-800-TECH-101 (1-800-832-4101)**

Ou visitez notre site Web à l'adresse  
<http://www.alpine-usa.com>

**ALPINE ÉLECTRONIQUE DE L'AMÉRIQUE, INC.**, 19145 Gramercy Place, Torrance, California 90501, U.S.A.

**N'envoyez pas de produits à cette adresse.**

Appelez notre numéro gratuit ou visitez notre site Web si vous recherchez un centre de service.