



## FDP 1.900 : ONE CHANNEL AMPLIFIER Operation / Configuration

### POWER PER CHANNEL:

- 1 x 500 wRMS @ 4ohms
- 1 x 850 wRMS @ 2ohms
- 1 x 500 wRMS @ 1 ohms
- 1 x 1700 wRMS (Two FDP 1.900s Bridged @ 4 ohms only)

### INPUT/OUTPUT CONFIGURATIONS

Because this is a one channel amplifier, if both left and right inputs are used, they are mixed to mono, which is useful for subwoofers.

### CROSSOVER CONFIGURATION

The 24 dB per octave crossover can be adjusted so this amplifier can function as:

1. Full range
  2. Low Pass for a subwoofer.
  3. Band Pass for a subwoofer or midbass of a 3 way speaker.v
  4. High Pass for a midbass, midrange or tweeter.
- The amplifier can be used full range with switch in HP position and frequency set to 10 Hz. HP is always on so it can be used as a subsonic filter.  
HP X1 frequency range is 10 Hz to 400 Hz.  
HP X10 frequency range is 100 Hz to 4000 Hz.  
LP: Adjustment range is 30 Hz to 350 Hz.  
Band Pass with switch in LP position and adjusting both HP and LP to desired frequency.
  - The remote volume control is always active.  
There is a clip distortion light on the remote volume control.  
If you see this light on, reduce volume until the light goes out so that you do not damage your speaker.
  - Phase is continuously adjustable between 0 degrees and 180 degrees. Adjust by measuring frequency response at the crossover frequency. Frequency response should be as smooth as possible.
  - 40 Hz EQ is adjustable between 0dB and +6dB.  
Measure the subwoofer frequency response and adjust EQ to get the smoothest frequency response.  
Avoid excess EQ boost because this will make the subwoofer sound "muddy" and cause the amplifier have clip distortion prematurely.

### AUTOMATIC POWER TURN ON/OFF

1. The best way to automatically turn the amplifier power on and off is to use the REM wire from your source radio connected to the REM amplifier terminal.
2. If your original equipment stereo or source radio has a BTL amplifier then the RCA inputs have an auto turn on sensing circuit. When you connect the high level BTL speaker wires to the RCA input the REM wire is not necessary.

## **RCA INPUT, BOTH LOW LEVEL AND HIGH LEVEL.**

The amplifier **LEVEL** control has sufficient adjustment range for both low level and high level input into the RCA jacks. A factory source radio that does not have RCA output, using the wires that are connected to the speakers, can be directly connected to the RCA jacks when the amplifier **LEVEL** control is adjusted to 8V.

## **SETTING LEVEL**

- Set the amplifier **LEVEL** control to minimum before you turn on the amplifier for the first time.
- For lowest distortion and lowest noise the amplifier **LEVEL** should be set at the lowest setting that yields sufficient loudness without distortion. For lowest noise your source radio volume control should be near maximum that does not cause distortion.
- To find the best amplifier **LEVEL** setting:  
With the amplifier **LEVEL** at minimum, slowly increase the source radio volume to around 3/4 without distortion. Then, slowly turn up the amplifier **LEVEL** control to the maximum desired loudness. Listen very carefully and turn down the amplifier **LEVEL** control if you hear any distortion.

## **SETTING SUBWOOFER HIGH PASS SUBSONIC FILTER:**

- A subwoofer should have a high pass filter often called a subsonic filter. The purpose of a subsonic filter is to limit very low frequencies that your subwoofer can not play loud enough without damage. Removing subsonic frequencies can allow your subwoofer to play louder.
- For a sealed box the high pass is typically set between 10 Hz and 30 Hz to increase power handling capacity.
- For a vented box the high pass filter must be set 5 Hz lower than the port tune frequency to prevent woofer damage.

# ONE AMPLIFIER IN HP, LP OR BP MODE:

## A1

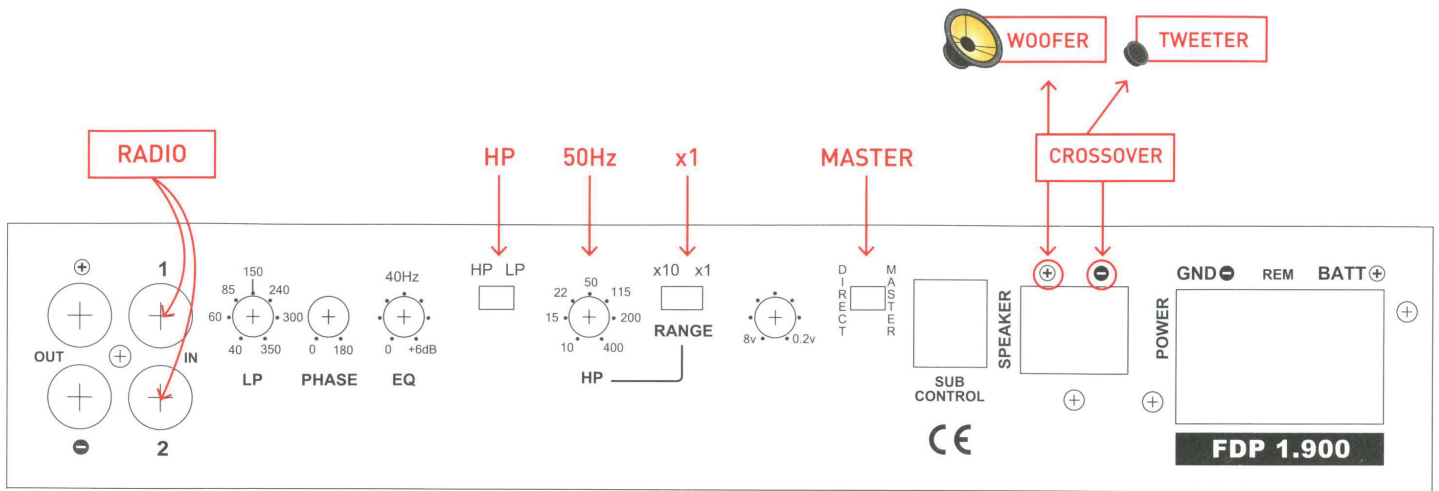

## A2

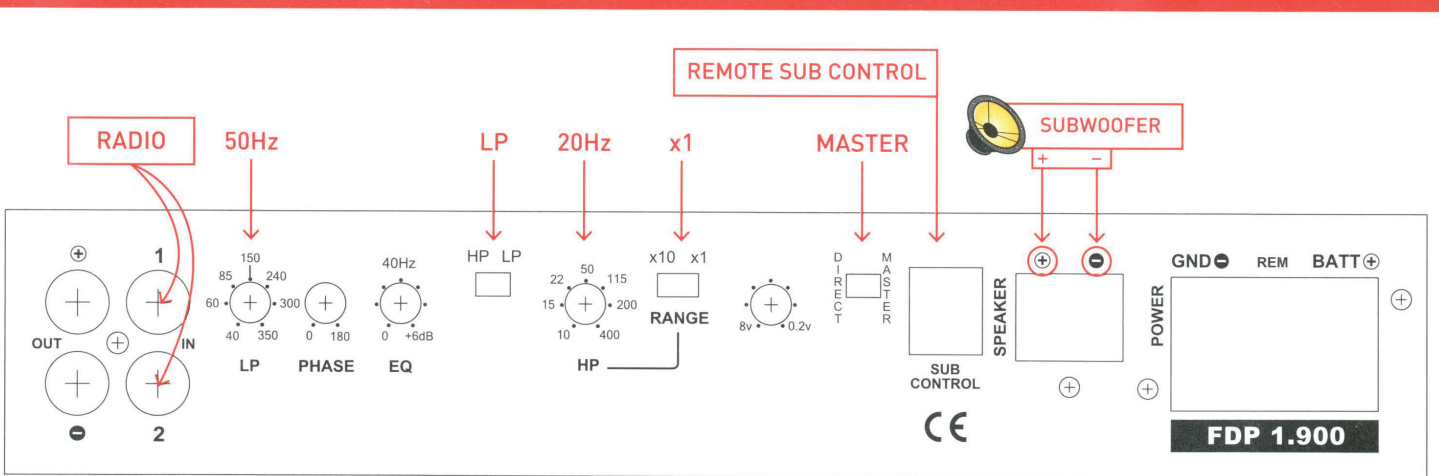



## MULTIPLE AMPLIFIERS IN PARALLEL CASCADE MODE:

TWO or more FPD 900.1 amplifiers are required.

- Use this mode when you have several speakers that will use the same crossover and loudness setting and will have one amplifier on each speaker.
- One example is a dual voice coil subwoofer and you use one amplifier on each voice coil.
- A second example is you have several subwoofers and will use one amplifier on each subwoofer.

Amplifier #1 will have “**MASTER**” switch selected.

Amplifier #2,3,4.... will have “**DIRECT**” switch selected.

Crossover and level controls will only function on amplifier #1.

By selecting “**DIRECT**” on amplifier #2,3,4.... all crossover and level controls are bypassed and the LEFT input channel must be used.

Master Amplifier #1 will receive the source signal on left and right channel.

Master Amplifier #1 RCA “out +” will connect to direct amplifier #2,3,4.... RCA “L IN”.

The LEFT input channel must be used.

One speaker + & - will connect to one Amplifier’s + & -.

### A4 (2 AMPS PARALLEL)

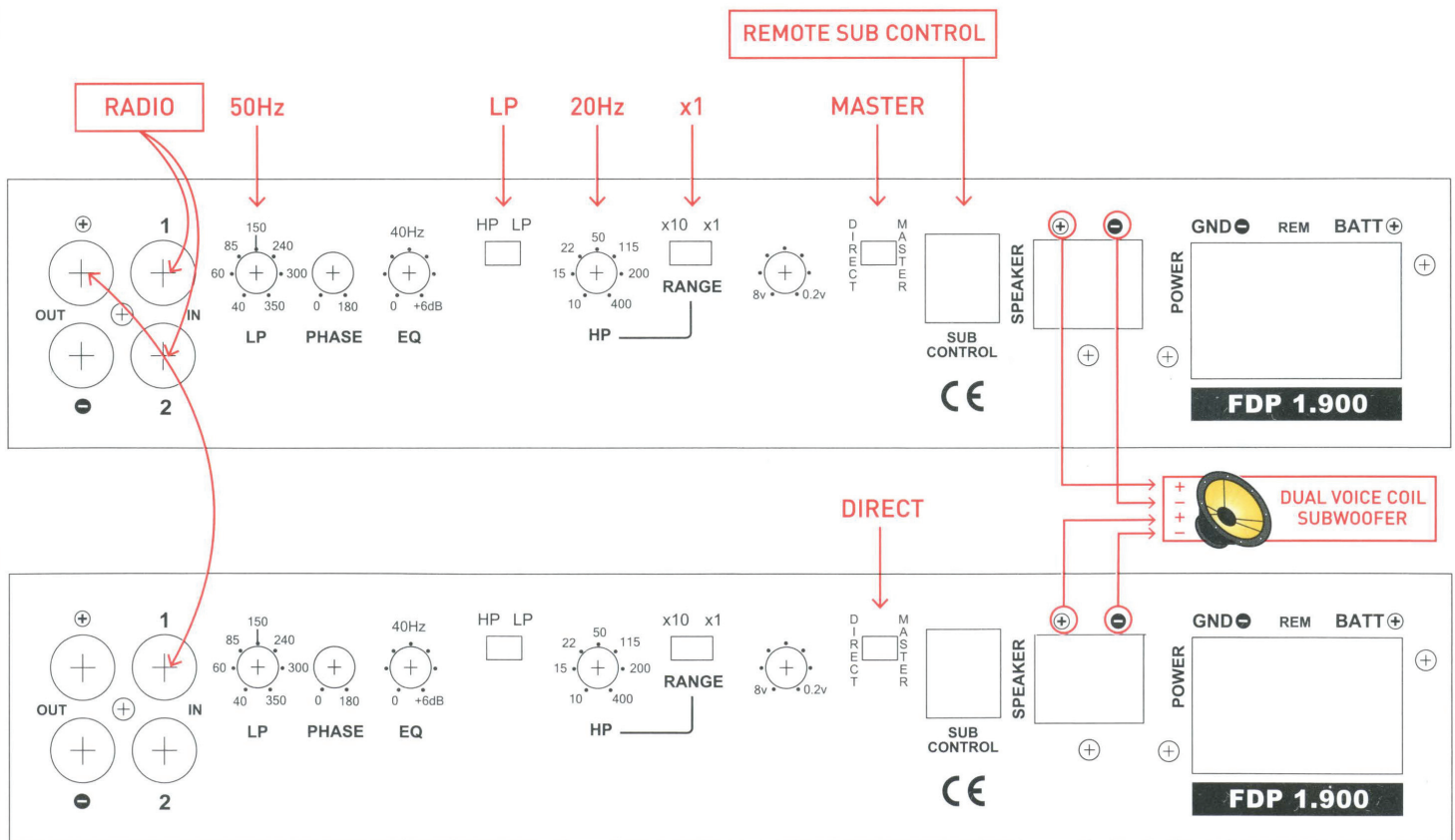

# POWER FUSES & BALANCED/UNBALANCED SWITCH:

## 1.900 POWER FUSES

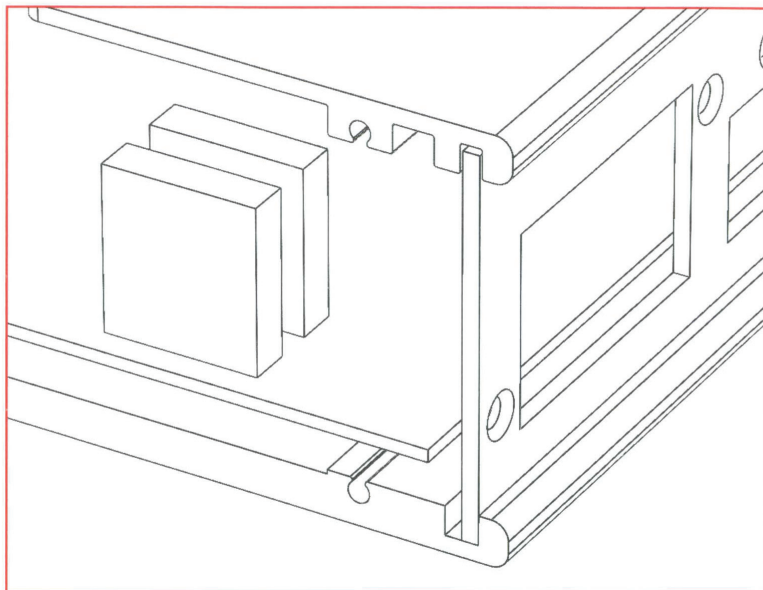
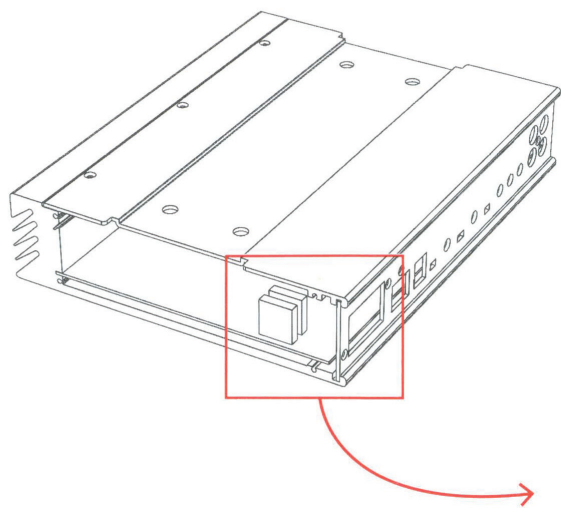

→ **TO USE:** Remove the end panel by the power terminals  
2 x 25 amp ATC fuse

## 1.900 BALANCED/UNBALANCED SWITCH

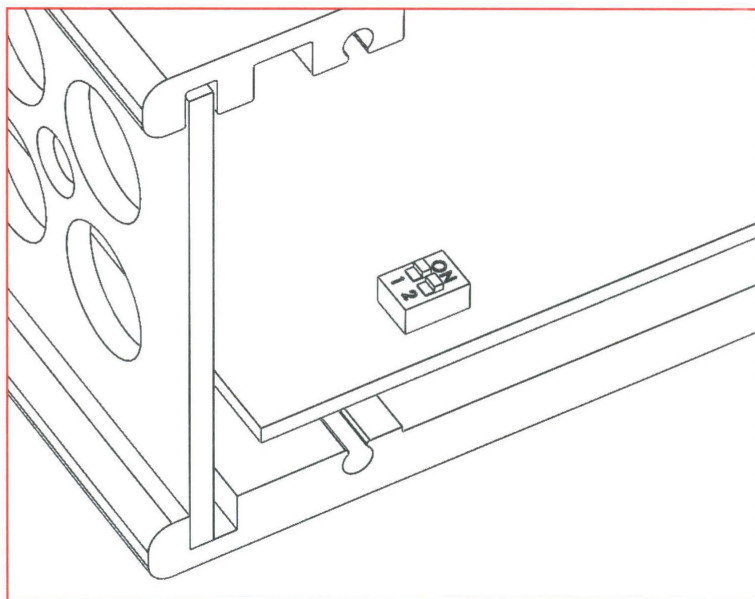
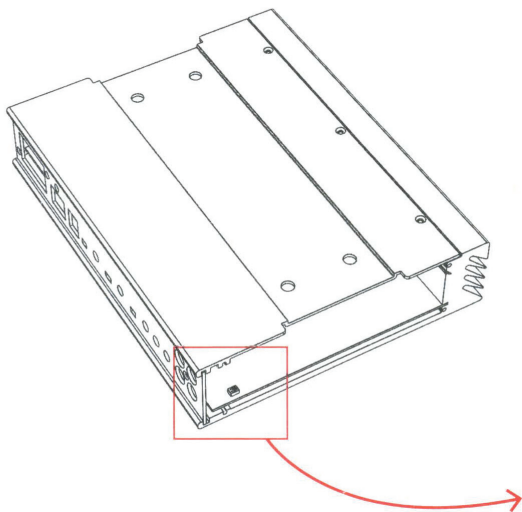

→ **TO USE:** Remove the end panel by the RCA jacks.  
The standard switch position is input ground "ON".  
Flip the switch "OFF" changes the input to "balanced input floating ground".  
To flip the switch, use a small pick or jewelers screw driver.

# **TROUBLESHOOTING:**

## **→ FOCAL SIGN DOES NOT LIGHT**

1. Measure the voltage at the amplifier power terminal.  
It should be between 12 and 15 volts.
2. Measure the voltage at the amplifier REM terminal.  
It should be between 12 and 15 volts.
3. If you are using BTL high level for automatic turn on, try connecting a REM wire.
4. Check your power and ground connections to be correct polarity + and - and they are tight.
5. Check battery connections.
6. Check the fuse in the REM wire.
7. Check fuse at battery.
8. Check fuse inside amplifier.  
The fuse is inside the right end cap beside the power terminals.  
The recommended ATC fuse size is two 25 amp.

## **→ FOCAL SIGN IS FLASHING**

1. Is the amp very hot?  
Wait a few minutes for it to cool down.  
You need to get more fresh cool air to the amplifier.  
Do not cover the amplifier or mount it flush into a hole.
2. If the amp is cold and the Focal sign is flashing, there is an internal fault. The amplifier must then be returned for service.

## **→ NO SOUND**

1. Is the Focal sign light off or flashing?
2. Is the source radio on and is there a sound signal coming from the source radio?
3. Use an ohm meter and measure the speaker wires for short circuit.
4. Check connections for small "wire whisker" that may be shorting between amplifier terminals or speaker terminals.
5. Use an ohm meter and measure the speaker for short circuit.
6. Double check your connections to the source radio.
7. Are you using the correct source radio wires and are they plugged into the correct amplifier RCA?
8. Double check your connections to the speakers and speaker crossovers.
9. Check that all amplifier switches are in the correct positions for your speaker set up.

## **→ AMPLIFIER BLOWS FUSE WHEN YOU TURN IT ON.**

1. Power and ground may be reversed.  
Check + and - polarity at amplifier and at battery.

## **→ SUBWOOFER REMOTE VOLUME CONTROL DOES NOT FUNCTION.**

1. Check that Remote Volume Control wire is plugged into the amplifier securely.
2. The Remote Volume Control will not function if the amp switch is "DIRECT". The switch must be in "MASTER".

## → SUBWOOFER REMOTE VOLUME CONTROL LED LIGHT.

1. While playing music the LED light should be Green.  
Occasional red LED light flash indicates that the amplifier has reached maximum loudness.
2. If the red LED light flashes with the beat of the music,  
TURN DOWN THE VOLUME before you damage your speaker.
3. If the red LED light is on continuous,  
TURN DOWN THE VOLUME before you damage your speaker.

## WARRANTY INFORMATION:

Focal America / Orca Design & Manufacturing supports their products and guarantees them to be free of manufacturing defects for a period of **1 year (non-transferrable) from the date of purchase, if purchased from and authorized retailer.** This time period is extended to **3 years (non-transferrable) from the date of purchase, if the amplifier is purchased from and installed by an authorized retailer, and no alterations** are made to the installation or setup of the amplifier outside of the authorized retailer.

This manufacturing **warranty does not extend to situations involving physical or installation damage, misuse, abuse, or modification.** If an amplifier malfunctions, please return it to the authorized retailer from which the amplifier was purchased to have the amplifier and/or installation inspected and to have the warranty period verified from date of purchase.

The authorized dealer will then work with Focal America / Orca Design & Manufacturing to obtain service, if necessary. If found to be a defect due to manufacturing, the item will be repaired or replaced with a refurbished amplifier. The amplifier will be returned to the authorized retailer when repairs are complete, so that the dealer can return the amplifier to you, or reinstall the amplifier to maintain the above mentioned warranty timeline.

## TECHNICAL SPECIFICATIONS:

<p>One X 500 watts at less than 1% THD into 4 ohms One X 850 watts at less than 1% THD into 2 ohms Two amps can be bridged, one X 1700 watts at less than 1% THD into 4 ohms Frequency Response 5 Hz to 25 kHz. S/N ratio 90 dB RCA input can use a BTL source or common ground source. RCA switch select balanced floating ground or grounded to minimize noise. Input sensitivity 200mV to 10 volts Slew Rate 13 V / <math>\mu</math>S</p>	<p>Variable high pass crossover 10 Hz to 4000 Hz, 24 dB Linkwitz-Riley Variable low pass crossover 40 Hz to 350 Hz, 24 dB Linkwitz-Riley Variable band pass crossover 10 Hz to 350 Hz, 24 dB Linkwitz-Riley Variable bass boost, 0 to +6dB at 40 Hz. Continuous phase adjustment from 0 to 180 degree. Subwoofer remote volume control includes a clipping indicator light. Recommended DC voltage operating range 11.5 to 14.4 volts. Minimum DC voltage operating range 8 to 16 volts. Length 7.71 inches Width 10 inches Height 1.97 inches Weight 6 pounds</p>
--	--