

English

### IMPORTANT SAFETY INSTRUCTIONS

**CAUTION** To avoid the risk of human injury or property damage, be sure to read and observe the following safety cautions.

**Have a specialist install and connect the speaker.** — Incorrect installation may lead to vehicle accident or malfunction.

**Avoid unstable installation.** — Make sure that the speaker will not rattle or displace. Otherwise, a displaced speaker may cause injury.

**Do not modify the speaker.** — Otherwise, smoke or fire may result.

**Do not touch the speaker.** — The speaker

becomes hot after extended operation. Touching it in such a condition may cause burns.

**Control listening volume at an optimum level.** — If the sound outside the vehicle is inaudible, a traffic accident may result.

**In case of abnormality, stop the use and disconnect the speaker.** — If operation is continued, smoke or fire may result. Disconnect the speaker and ask servicing.

**NOTE:**

**Connect to an amplifier with an RMS power equal to or lower than that of the speaker.**

— If the RMS power of the amplifier is higher than that of the speaker, increase the speakers and connect them in series or reduce the speaker input power.

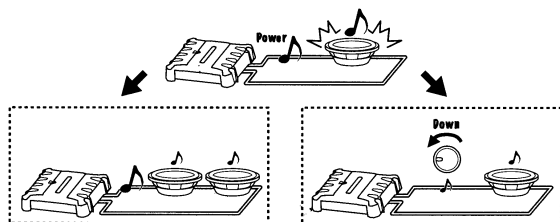

**Do not exceed the impedance value with which the amplifier operation is guaranteed.** — When using multiple speakers, calculate their total impedance and use an impedance value within the range in which the operation of the amplifier is guaranteed.

<Example>

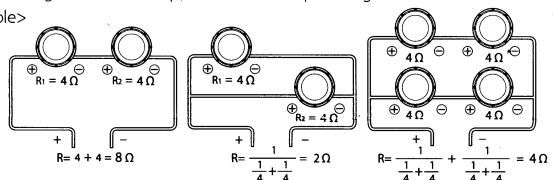

Español

### INSTRUCCIONES DE SEGURIDAD IMPORTANTES

**PRECAUCIÓN** Para evitar el riesgo de que se lesionen personas o se dañen propiedades, asegúrese de leer y tomar las precauciones de seguridad siguientes.

**Solicite a un especialista que instale y conecte el altavoz.** — La instalación incorrecta puede ser la causa de que produzca un accidente del vehículo o un fallo de funcionamiento.

**Evite una instalación inestable.** — Asegúrese de que el altavoz no vibre ni se desplace. De lo contrario, un altavoz que se desplace podrá causar lesiones.

**No modifique el altavoz.** — De lo contrario podrá salir humo o producirse un incendio.

**No toque el altavoz.** — El altavoz se calienta después de funcionar durante mucho tiempo

seguido. Tocar lo bajo tales condiciones puede causar quemaduras.

**Controle el volumen de audición en un nivel óptimo.** — Si el sonido del exterior del vehículo no se puede oír, puede que se produzca un accidente de tráfico.

**En el caso de producirse alguna anomalía, deje de utilizar el altavoz y desconéctelo.** — Si se continúa utilizando el altavoz bajo estas condiciones, puede que salga humo o se produzca un incendio. Desconecte el altavoz y solicite reparaciones.

**NOTA:**

**Conecte a un amplificador con una potencia RMS igual o inferior a la del altavoz.** — Si la potencia RMS del amplificador es superior a la del altavoz, aumente el número de altavoces y conéctelos en serie, o reduzca la potencia de entrada del altavoz.

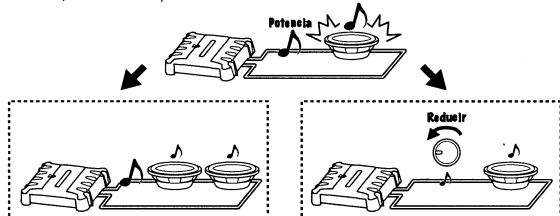

**No sobrepase el valor de impedancia con el que el funcionamiento del amplificador está garantizado.** — Cuando utilice múltiples altavoces, calcule el valor total de sus impedancias y utilice un valor de impedancia que se encuentre dentro del margen en el que el funcionamiento del amplificador está garantizado.

<Ejemplo>

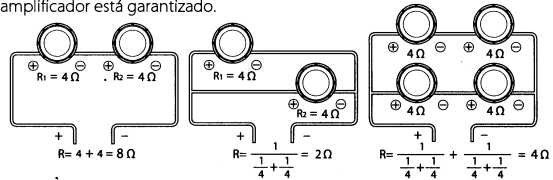

Français

### CONSIGNES DE SÉCURITÉ IMPORTANTES

**ATTENTION** Pour éviter les risques de blessures ou de dommages matériels, prière de lire les consignes de sécurité suivantes et d'en tenir compte.

**Le haut-parleur doit être installé et raccordé par un spécialiste.** — Un accident de la route ou un dysfonctionnement peut être causé par une mauvaise installation.

**L'installation doit être stable.** — S'assurer que le haut-parleur ne vibre pas et ne bouge pas. Un haut-parleur mal fixé peut causer des blessures.

**Ne pas modifier le haut-parleur.** — Sinon de la fumée ou un incendie pourrait se produire.

**Ne pas toucher le haut-parleur.** — Le haut-parleur est chaud après une longue période de fonctionnement. Il peut alors causer de brûlures.

**Régler le volume à un niveau optimal.** — Un accident de la route peut se produire si les sons extérieurs au véhicule ne sont pas audibles.

**En cas d'anomalie, cesser d'utiliser le haut-parleur et le débrancher.** — Sinon de la fumée ou un incendie peut se produire. Débrancher le haut-parleur et le faire réparer.

**REMARQUE:**

**Raccorder à un amplificateur dont la puissance nominale (RMS) est égale ou inférieure à celle du haut-parleur.** — Si la puissance nominale (RMS) de l'amplificateur est supérieure à celle du haut-parleur, augmenter le nombre de haut-parleurs et les raccorder en série, ou réduire la puissance d'entrée du haut-parleur.

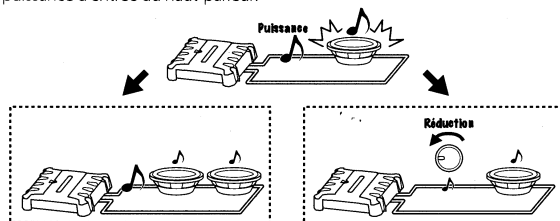

**Ne pas excéder l'impédance à laquelle le fonctionnement de l'amplificateur est garanti.** — Si plusieurs haut-parleurs sont utilisés, calculer leur impédance totale, sachant que celle-ci doit être dans la plage garantissant le fonctionnement de l'amplificateur.

<Exemple>

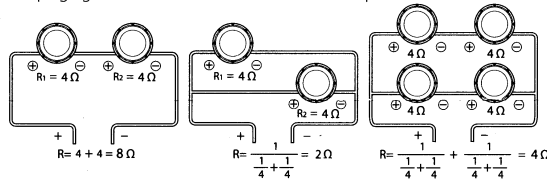

Português

### INSTRUÇÕES DE SEGURANÇA IMPORTANTE

**PRECAUÇÃO** Para evitar o risco de lesões ou danos materiais, certifique-se de que lê e respeita as seguintes precauções de segurança.

**Recorra a um técnico especializado para a instalação do altifalante.** — Uma instalação incorreta pode provocar um acidente ou avaria do veículo.

**Evite uma instalação instável.** — Certifique-se de que o altifalante não faz pequenos ruídos nem se desloca. Caso contrário, a deslocação de um altifalante pode provocar lesões.

**Não modifique o altifalante.** — Caso contrário, pode ocorrer fumo ou um incêndio.

**Não toque no altifalante.** — O altifalante

fica quente após um longo período de funcionamento. Tocar-lhe nessa altura pode provocar queimaduras.

**Ajuste o volume de escuta para o nível ideal.** — Se não conseguir escutar o som proveniente do exterior do veículo, pode ocorrer um acidente rodoviário.

**Em caso de anomalia, pare de utilizar o altifalante e desligue-o.** — Se continuar em funcionamento, pode ocorrer fumo ou um incêndio. Desligue o altifalante e solicite assistência técnica.

**NOTA:**

**Ligue a um amplificador com uma potência RMS igual ou inferior à do altifalante.** — Se a potência RMS do amplificador for superior à do altifalante, aumente os altifalantes e ligue-os em série ou reduza a potência de entrada do altifalante.

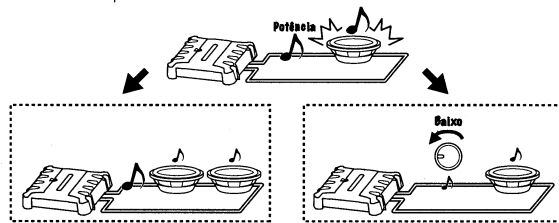

**Não exceda o valor de impedância que garanta o funcionamento do amplificador.** — Quando utilizar vários altifalantes, calcule a sua impedância total e use um valor de impedância dentro do intervalo que garanta o funcionamento do amplificador.

<Exemplo>

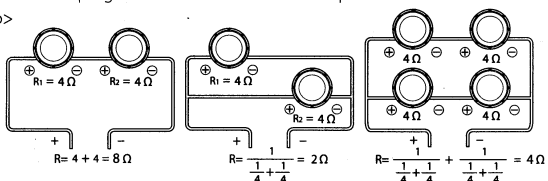

## Technical specifications

	SYMBOL	UNIT	VALUE
Nominal Impedance	Z	$\Omega$	4
DC Resistance	Revc	$\Omega$	3.2
Voice Coil Inductance	Levc	mH	2.03
Piston Area	Sd	sq.m	0.042
Force Factor	BL	T-m	10.8
Volume Acoustic Compliance	Vas	liter	32.9
		cft	1.162
Moving Mass	Mms	g	148.0
Resonance Frequency	Fs	Hz	36
Mechanical Q Factor	Qms		5.747
Electrical Q Factor	Qes		0.907
Total Q Factor	Qts		0.783
Peak Excursion	Xmax	mm	7.5
Displacement		liter	0.803
		cft	0.028
Mounting Depth		mm (inch)	80 (3-1/8)
Voice Coil Diameter		mm (inch)	50 (1-15/16)
Weight of Magnet		g (oz)	1080 (38.0)
Net Weight		kg (lb)	4.4 (9.7)
Sensitivity		dB/W at 1m	83.5
Frequency Response		Hz	41 ~ 200

## Recommended Enclosures

### ■ SEALED

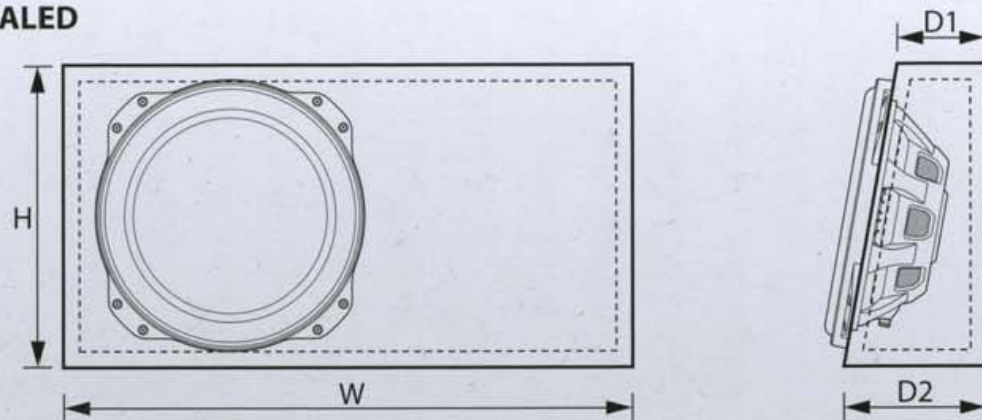

\* W, H, D : External Dimensions

Type	Inner Volume	W	H	D1	D2	Mounting Hole	Displacement
SEALED	0.6 cft (17.0 Liter)	717 mm (28-1/4")	324 mm (12-3/4")	96 mm (3-3/4")	158 mm (6-1/4")	235 mm (9-1/4")	0.028 cft (0.803 Liter)

Use 19 mm (3/4 inch) thick Medium Density Fiberboard (MDF) or High Density Particleboard.

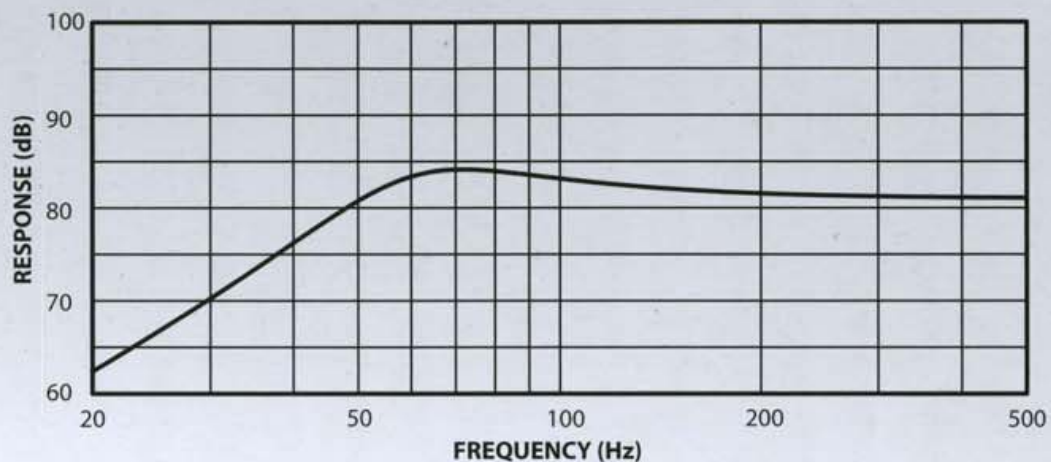

# XR-W10F

TEMPLATE

GABARIT

PLANTILLA

GABARITO



1

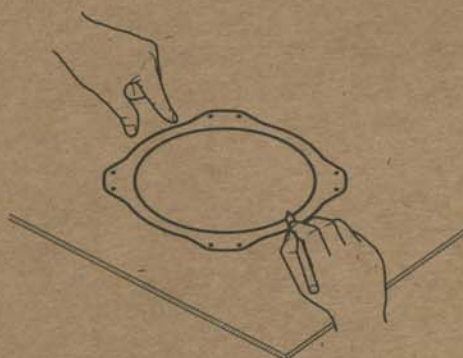

2

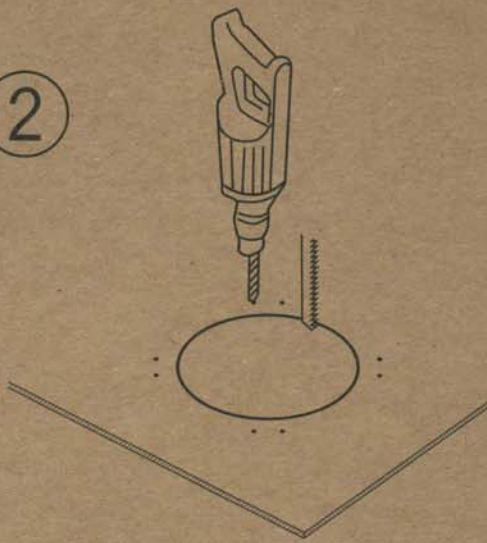

3

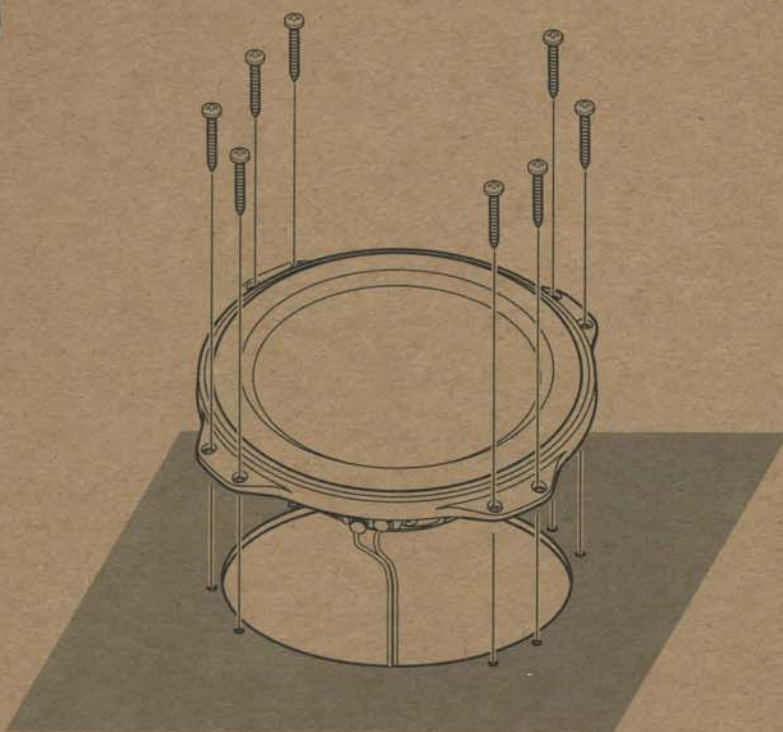

ø235mm  
(9-1/4)

37mm  
(1-7/16)

8-ø2.5mm  
(1/8)

R146.5mm  
(5-3/4)

ø315mm  
(12-3/8)



Corrugated  
Recycles  
Matériaux  
Recyclables

H41-0181

Andorra

Estimado Usuario de los productos Kenwood.
Gracias por haber elegido este Producto Kenwood.
Si resulta defectuoso bajo condiciones normales de funcionamiento...

Iceland

Kæri notandi Kenwood tækja.
Til hamingju með nýja Kenwood tækib þitt.
Ei einhverji framleiðslugættari koma í ljós við vengjuna...

Malta

Chaziz Klient tal-Prodotti Kenwood.
Grazzi talli ghazit dan il-prodott "KENWOOD".
Jekk qatq inqalaxi xi difett waqt l-uzzu normal...

Kenwood Marant Gard

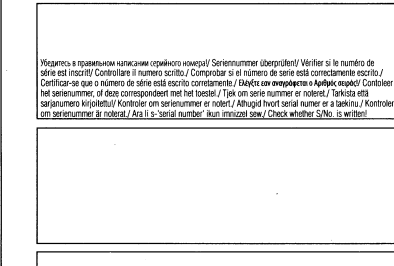

Уважаю в правлении членина грешков имен! Серииummer überprüfert! Verifier si le numero de serie est inscrit!
Certifico-se que o numero de serie está escrito corretamente! Dáttekna og vengjuna Afþykkt ekkert!
Certifico che il numero di serie corrisponde a quello dichiarato! Tiltal um serie númer og votttal.

Наименование модели и серийный номер/ Identification du produit/ Geräte-Typ und Seriennummer/ Modelo y Número de serie/ Produkt navn og serie nummer/
Modèle y Numéro de série/ Malli ja sarjannúmer/
Modell og Seriennummer/ Modelo e numero de série/
Apparat typ & serienummer/ Identificative van het produkt/
Módel heiti og raðnúmer/ Il-Modul u-Serial number/
Model number & serial number

Norge

Kjære kunde,
Takk for at De valgte dette Kenwood-produktet.
Hvis det oppstår feil under normal bruk, vennligst ta kontakt med en av de autoriserte forhandlerne...

Schweiz

Sehr geehrter Benutzer von KENWOOD Produkten.
Herzlichen Dank, dass Sie sich für dieses Kenwood-Produkt entschieden haben.
Falls ein Defekt unter normalen Betriebsbedingungen eintritt...

Swizzera

Gentile cliente, la ringraziamo per aver acquistato questo prodotto KENWOOD.
Se, in normali condizioni di funzionamento, questo dovesse risultare difettoso, la preghiamo di contattare il nostro distributore ufficiale al seguente indirizzo.
Tale nostro distributore sarà a sua disposizione per qualunque informazione.

Suisse

Chez utilisateur de KENWOOD.
Merci d'avoir choisi ce produit de KENWOOD.
En cas de panne sous conditions d'opérations normales, veuillez s.v.p. contacter votre distributeur officiel mentionné ci-dessous.

Sverige

Bästa Kenwood kund!
Tack för att Ni valt denna Kenwood-produkt.
För Kenwood-produkt som sålda i Sverige gäller Komvarettens RFR 1. Om EUI för Kenwood-produkt inte fungerar korrekt eller är felaktigt, under normalt handhavande...

Dear Customer,

Thank you for purchasing this kenwood product. As mentioned in the pages of this booklet, our warranty is only valid in the countries listed. If your country is not listed please contact your retailer for information on warranty procedure, or write to:
KENWOOD Corporation Customer Information Center
1-162-0, Hakusan, Midori-ku, Yokohama-shi, Kanagawa, 226-8525 Japan

Suomi

KENWOOD ELECTRONICS EUROPE B.V.

Kenwood-tuotteen käyttäjälle:
Kiitos siitä, että päätit ostaa tämän Kenwood-tuotteen (jäljempänä "tuote"). Josiote osto on valittu normaaleissa käyttöolosuhteissa, se korjataan tai vaihdetaan ilmaiseksi tämän tuotteen valmistajan mukaisesti.
Jos tuote on ostettu Suomessa EU:n jäsenmaassa siihen liittävällä kalliulla, edellyttämällä Kenwood-tuotteen virallisen maahantuojan, tuotteen jälleenviehyksen, huoltoajan tuotteen kanssa EU:n alueella toimivan, Kenwood-tuotteen myyjän välittämällä puolesta.
Etsiä samalla otettiin huomioon, että tuote on tarkoitettu sellä tavalla, josta käy ilmi ostajalleen. Jos tuote on ostettu EU:n ulkopuolella, se täytyy toimittaa takaisin tuotteen myyjälle välittämällä puolesta.

Belgique et Grand-duché de Luxembourg

Chez Utilisateur de Produits Kenwood.
Nous vous remercions d'avoir choisi ce produit Kenwood ("le Produit"). Si celui-ci, dans des conditions d'utilisation normales, de panne sous conditions d'opérations normales, veuillez s.v.p. contacter votre distributeur officiel mentionné ci-dessous.

KENWOOD ELECTRONICS BELGIUM N.V.

(a) Vous identifiez et adressez complètement.
(b) Le certificat d'achat ou tout autre document établissant la date d'acquisition du Produit assure d'un document établi dans la CEE.
(c) Le dommage causé au Produit résultant d'une négligence, d'un accident, de modifications, d'une installation ou d'un montage effectués, d'une utilisation incorrecte de l'utilisation de pièces de rechange appropriées.
(d) Le dommage causé au Produit par une sur-impulsion dans tout autre mode, lors d'une utilisation normale, et d'usage inadéquat, un cas de force majeure, une utilisation pour quelque cause que ce soit, ou avec une tension électrique adéquate inconnue ou toute autre cause hors du produit au condition de la présente Garantie.

Danmark

ELEKTRONIK-SERVICE

Til brugeren af Kenwood's produkter:
Hvis der opstår fejl under normal anvendelse, vil produktet blive repareret eller udskiftet uden beregning i overensstemmelse med betingelserne i dette garantibevis.
Hvis produktet er købt i EU-land og der er tale om et defekt under normale anvendelse, vil produktet blive repareret eller udskiftet uden beregning i overensstemmelse med betingelserne i dette garantibevis.

Belgie & Groothertogdom Luxemburg

Graetzte gebuerker van Kenwood produkten.
Wij danken U voor het kiezen van dit Kenwood product (het "Product"). Indien het Product bij normaal gebruik, gebreken zou vertonen, zal het gratis worden hersteld of vervangen overeenkomstig de bepalingen van deze Garantiekaart.

KENWOOD ELECTRONICS BELGIUM N.V.

van aankoop bij een detailhandelaar gevestigd in Europa vermeld is:
(a) De volledige naam en het adres van de detailhandelaar bij wie het Product is aangekocht.
(b) Het serienummer en de datum van aankoop van het Product.
(c) Het serienummer en de datum van aankoop van het Product.
(d) Het serienummer en de datum van aankoop van het Product.
(e) Het serienummer en de datum van aankoop van het Product.

Deutschland

KENWOOD ELECTRONICS DEUTSCHLAND GMBH

Sehr geehrter Kunde,
Wir danken Ihnen für den Kauf dieses Kenwood-Produkts.
Sollte dieses Produkt unter normalen Betriebsbedingungen fehlerhaft werden, wird es Ihnen kostenlos repariert oder ausgetauscht.
(a) Vollständiger Name und Adresse des Einzelhändlers, bei dem das Produkt gekauft wurde.
(b) Seriennummer und die Modellbezeichnung des Produkts.
(c) Seriennummer und die Modellbezeichnung des Produkts.

KENWOOD ELECTRONICS BELGIUM N.V.

Leuvensteenvoeg 248 J, 1800 Vijvoorde, Belgium. Tel. 32(0)757-9060 www.kenwood.be

KENWOOD ELECTRONICS EUROPE B.V.

Rembrücker-Str. 15 D-63150 Heusenstamm. Tel. 0049-6104-6901-0 www.kenwood.de

KENWOOD ELECTRONICS DEUTSCHLAND GMBH

Rembrücker-Str. 15 D-63150 Heusenstamm. Tel. 0049-6104-6901-0 www.kenwood.de

Nederland

Gauche gebruiker van Kenwood producten. Wij danken U voor het kiezen van de Kenwood product (het "Product").

- (c) De volledige naam en het adres van de detailhandelaar bij wie het Product wordt aangekocht.
(d) Het serienummer en de naam van het model van het Product.

- (a) garantieaanspraken voor zijn rekening uit te voeren;
(b) schade veroorzaakt door overbelasting, onregelmatig, onjuist gebruik, gebrekkige installatie of verpakking, wijzigingen of gebruik van ongeschikte wisselstukken;
(c) schade van andere aard voortvloeiende uit het gebruik van het Product onder normale gebruiksomstandigheden.

Kenwood Electronics Europe B.V.
Amsterdamseweg 37, 142Z AX Uithoorn
Tweede etage
Tel. 020-97319900
www.kenwood.nl

Indien het Product gebruikt in een Europees land waar het onderworpen is aan standaarden en voorschriften die verschillend zijn van degenen van toepassing in het land van de oorspronkelijke leverancier van het Product, wordt de garantie niet gegeven op de volgende voorwaarden:
(a) Het Product wordt gebruikt in een ander land dan dat van de oorspronkelijke leverancier van het Product.

Deze Garantie wordt gegeven aan alle personen die op rechtmatige wijze het Product verpakking hebben.

U dient deze Garantiekaart zorgvuldig bij te houden aangezien zij de enige bewijsstuk is om uw aanspraak op deze Garantie toe te doen.
De garantie voor het Product is geldig gedurende één jaar vanaf de datum van de oorspronkelijke aankoop bij een detailhandelaar van Kenwood product. De garantie faalt zowel op de volgende gebieden als op de volgende gebieden:
(a) Beschadiging van het Product door verkeerd gebruik.
(b) Beschadiging van het Product door gebruik van niet-originele onderdelen of onderdelen van andere merken.

- (e) Het serienummer en de naam van het model van het Product.
(f) Het serienummer en de naam van het model van het Product.
(g) Het serienummer en de naam van het model van het Product.

Deze Garantie wordt gegeven aan alle personen die op rechtmatige wijze het Product verpakking hebben.
Onder de hierboven vermelde voorwaarden zal het Product gratis worden gerepareerd of vervangen. Dit recht wordt op geen enkele wijze anderszins beperkt of beperkt door andere bepalingen van de oorspronkelijke leverancier van het Product.

Portugal

Caro utilizador dos produtos Kenwood. Obrigamo por ter escolhido este produto Kenwood (abaixo denominado designado por "Produto").

H. F. GONCALVES, Lda.

num revendedor estabelecido no seu pais.
(c) Nome completo e endereco do revendedor ou do Produto foi adquirido por meio de um contrato de compra e venda.

Osterreich

Sehr geehrte Kunden, wir danken Ihnen für den Kauf dieses Kenwood-Produkts.
(a) Der Seriennummer und die Modellbezeichnung des Produkts.
(b) Der Seriennummer und die Modellbezeichnung des Produkts.

H. F. GONCALVES, Lda.

Por favor, conserve este Cartão de Garantia para o caso de alguma reclamação a ser feita.
O Produto tem garantia de um ano a partir da data de sua aquisição original num revendedor autorizado de produtos Kenwood.
A garantia cobre peças e mão-de-obra, e a reparação será efectuada gratuitamente. Reservas em relação de substituição o Produto caso este não possa ser reparado de modo económico.

Esta garantia é válida para todos os países onde o Produto é comercializado.
(a) Nome completo e endereço do revendedor ou do Produto foi adquirido por meio de um contrato de compra e venda.

Bitte bewahren Sie diese Garantiekarte sorgfältig auf.
(a) Der Seriennummer und die Modellbezeichnung des Produkts.
(b) Der Seriennummer und die Modellbezeichnung des Produkts.

Ελλάδα

Για τους χρήστες των προϊόντων KENWOOD.
Εάν αγοράσετε το προϊόν της εταιρείας KENWOOD, θα έχετε αυτόματα έναν χρόνο εγγύηση από τον κατασκευαστή.
Η εγγύηση αφορά το προϊόν όπως αγοράστηκε, με την προϋπόθεση ότι το προϊόν έχει χρησιμοποιηθεί σύμφωνα με τις οδηγίες χρήσης που συνοδεύονται με το προϊόν.
Ο κατασκευαστής δε φέρει ευθύνη για ζημιές που προκύπτουν από τη χρήση του προϊόντος που δεν είναι κατάλληλο για χρήση σε αυτές τις συνθήκες.

Г.Ε.ΑΗΜΗΤΡΟΥ Α.Ε.Β.Ε.

Αυτό το προϊόν είναι κατασκευασμένο για να ανταποκρίνεται σε όλα τα εθνικά και τοπικά πρότυπα και να κινείται ασφαλώς στο εθνικό και τοπικό δίκτυο.
Αυτό το προϊόν είναι κατασκευασμένο για να ανταποκρίνεται σε όλα τα εθνικά και τοπικά πρότυπα και να κινείται ασφαλώς στο εθνικό και τοπικό δίκτυο.

France

Cher Utilisateur de Produits Kenwood,
Nous vous remercions d'avoir choisi ce produit Kenwood ("le Produit").
(a) Votre identité et l'adresse complète.
(b) Le numéro de série et le nom du modèle du produit.

España

Estimado usuario de los productos Kenwood. Gracias por haber elegido este producto Kenwood ("el Producto").
(a) Nombre completo, dirección y selo del distribuidor en el que efectuó la compra del producto.
(b) Nombre completo y dirección de la tienda de donde se adquirió el producto.

KENWOOD IBERICA S.A.

Este producto ha sido diseñado en un país europeo donde rigen otros estándares y requerimientos que aquellos aplicables en el país de la venta original por el fabricante en Europa.
(a) Nombre completo y dirección de la tienda de donde se adquirió el producto.

Italia

All'attenzione di prodotti Kenwood. La ringraziamo aver scelto questo prodotto Kenwood ("il Prodotto").
(a) Nome, cognome ed indirizzo del rivenditore da cui il Prodotto è stato acquistato.
(b) Nome, cognome ed indirizzo del rivenditore da cui il Prodotto è stato acquistato.

KENWOOD ELECTRONICS ITALIA S.p.A.

Questo documento è necessario per il recupero di un prodotto o di un ricambio.
(a) Nome, cognome ed indirizzo del rivenditore da cui il Prodotto è stato acquistato.

KENWOOD ELECTRONICS UK LTD.

The Serial Number and Model Name of the Product. If this information cannot be provided, or if the Product has been modified or altered in any way since the date of purchase, Kenwood Corporation reserves the right to refuse the Product under this Warranty.
(a) The name of the retailer from whom the Product was purchased.
(b) The name of the retailer from whom the Product was purchased.

KENWOOD ELECTRONICS UK LTD.

Please keep this Warranty Card as you will need it should a claim be necessary.
The Product is warranted for one year from the date of original purchase from a retailer of Kenwood products.
(a) The name of the retailer from whom the Product was purchased.

KENWOOD ELECTRONICS ITALIA S.p.A.

Questo documento è necessario per il recupero di un prodotto o di un ricambio.

KENWOOD ELECTRONICS ITALIA S.p.A.

Questo documento è necessario per il recupero di un prodotto o di un ricambio.

KENWOOD ELECTRONICS ITALIA S.p.A.

Questo documento è necessario per il recupero di un prodotto o di un ricambio.

**U.S.A. KENWOOD USA CORPORATION**

This warranty will be honored only in the U.S.A.

**KENWOOD LIMITED WARRANTY FOR CAR STEREO COMPONENTS**

**HOW LONG IS THE WARRANTY**

Kenwood U.S.A. Corporation ("Kenwood") warrants this product for a period of one (1) year from the date of original purchase.

**WHAT IS COVERED AND WHAT IS NOT COVERED**

Except as specified below, this warranty covers all defects in material and workmanship in Kenwood car stereo components. The following are not covered by the warranty:

- 1. Any product which is not distributed in the U.S.A. by Kenwood or which is not purchased in the U.S.A. from an authorized Kenwood car stereo dealer or an automobile dealer, unless the product is purchased through the U.S.A. Military Exchange Service.
2. Any product on which the serial number has been defaced, modified or removed.
3. Damage, deterioration or malfunction resulting from:
a. Any shipment of the product (claims must be presented to the carrier).
b. Installation or removal of the product.
c. Accident, acts of nature, misuse, abuse, neglect, unauthorized product modification or failure to follow instructions supplied with the product.
d. Repair or attempted repair by anyone not authorized by Kenwood.
e. Any other cause which does not relate to a product defect.

**WHO IS PROTECTED**

This warranty is enforceable only by the original purchaser.

**WHAT WE WILL PAY FOR**

We will pay for all labor and material expenses for covered items. Payment of shipping charges is discussed in the next section of this warranty.

**HOW TO OBTAIN WARRANTY SERVICE**

If your KENWOOD product ever needs service:

- 1. Take or ship it to any KENWOOD Authorized Service Center in the U.S.A. along with a complete description of the problem. (If you are uncertain as to whether a Service Center is authorized, please call 1-800-KENWOOD for the nearest Service Center. 1-800-536-9668).
2. Although you must pay any shipping charges if it is necessary to ship the product for warranty service, we will pay the return shipping charges if the repairs are covered by the warranty within the United States.
3. Whenever your units are taken or sent for warranty service, you must include a copy of the original dated sales receipt as proof of warranty coverage.

**LIMITATION OF IMPLIED WARRANTIES**

ALL IMPLIED WARRANTIES, INCLUDING WARRANTIES OF MERCHANTABILITY AND FITNESS FOR A PARTICULAR PURPOSE, ARE LIMITED IN DURATION TO THE LENGTH OF THIS WARRANTY.

**EXCLUSION OF DAMAGES**

KENWOOD'S LIABILITY FOR ANY DEFECTIVE PRODUCT IS LIMITED TO THE REPAIR OR REPLACEMENT OF THE PRODUCT AT OUR OPTION. KENWOOD SHALL NOT BE LIABLE FOR:

- 1. INSTALLATION OR REMOVAL CHARGES, DAMAGE TO OTHER PROPERTY CAUSED BY ANY DEFECTS IN KENWOOD CAR STEREO COMPONENTS, DAMAGES BASED UPON INCONVENIENCE, LOSS OF USE OF THE PRODUCT, OR
2. ANY OTHER DAMAGES, WHETHER INCIDENTAL, CONSEQUENTIAL OR OTHERWISE.
SOME STATES DO NOT ALLOW LIMITATIONS ON HOW LONG AN IMPLIED WARRANTY LASTS AND/OR DO NOT ALLOW THE EXCLUSION OR LIMITATION OF INCIDENTAL OR CONSEQUENTIAL DAMAGES, SO THE ABOVE LIMITATIONS AND EXCLUSIONS MAY NOT APPLY TO YOU.

This warranty gives you specific legal rights, and you may also have other rights which vary from state to state.

If a problem develops during or after the Limited Warranty Period, or if you have any questions regarding the operation of the product, you should contact your KENWOOD Authorized Dealer or Authorized Service Center. If the problem or your question is not handled to your satisfaction, please contact our Customer Relations Department at the address listed below:

KENWOOD USA CORPORATION
P.O. Box 22745, 2201 East Dominguez Street, Long Beach, CA 90801-5745
Tel: (310) 639-5300

**ATTENTION**

This card and receipt (or invoice) are necessary to purchase a new panel in case of theft or damage.

**MILITARY**

Units purchased through the U.S.A. military exchange service overseas may be serviced under warranty in the continental U.S.A., subject to the following conditions.

- 1) The original warranty is in effect.
2) Proof of purchase is provided to the servicer.

**WARRANTY FOR MILITARY MARKET**

Kenwood corporation is proud of the quality and workmanship of its audio equipment. This unit has been properly designed, tested and inspected before it was shipped to you. If properly installed and operated in accordance with instructions furnished, it should give you an optimum reliable performance.

**WARRANTY PERIOD**

This product is warranted for a period of (1) year from the date of the original purchase.

**SCOPE OF WARRANTY**

Except as specified below, this warranty covers all defects in materials and workmanship of the Kenwood brand products.

During the warranty period, any authorized Kenwood Service Center in the military market listed in the back of this warranty card will provide you free-of-charge both parts and labor required to correct any defect in materials or workmanship.

The following are not covered by this warranty:

- 1. Voltage conversions.
2. Periodic check-ups which do not disclose any defect covered by the warranty.
3. Cabinets, grilles, other exterior finishes, belts, tape heads, and other non-durable parts and accessories.
4. Units on which the serial number has been effaced, modified or removed.
5. Installation and/or removal charges.
6. Damaged magnetic tapes.
7. House call charges for any repairs.
8. Shipping or delivery charges to or from an authorized Kenwood Service Center.
9. This warranty will not cover any failure that is due to any of the following conditions in accordance with the visual inspection of the authorized Kenwood Service Center:
\* Improper maintenance or repair, including the installation of parts or accessories that do not conform to the quality and specifications of the original parts.
\* Misuse, abuse, neglect, unauthorized product modification or failure to follow instructions contained in the Owner's Manual.
\* Accidental or intentional damages.
\* Repairs or attempted repairs by an unauthorized agency. (All repairs must be performed at an authorized Kenwood Service Center.)
\* Damages or deteriorations caused during shipment (Claims must be presented to the carrier).
\* Damages or deteriorations resulting from removal and/or replacement.

**PURCHASER'S RESPONSIBILITIES**

As the purchaser of a new Kenwood brand product, you are requested to do the following in order to obtain Kenwood warranty service:

- 1. Retain your sales slip or other evidence of purchase for proving your eligibility for requesting Kenwood warranty service.
2. Make your unit available to an authorized Kenwood Service Center in the military market for inspection and approved warranty service, or ship your unit in its original carton box or equivalent, fully insured and shipping charges prepaid, to the authorized Kenwood Service Center.

**LIMITATION OF IMPLIED WARRANTIES**

Any and all implied warranties, including warranties of merchantability and fitness for a particular purpose, shall be limited in duration to the length of this warranty.

**EXCLUSION OF CERTAIN DAMAGES**

KENWOOD'S liability for any defective product is limited to the repair or replacement of said product at our option, and shall not include damages of any kind, whether incidental, consequential or otherwise, except to the extent prohibited by applicable law.

**ATTENTION**

This card and receipt (or invoice) are necessary to purchase a new panel in case of theft or damage.

**KENWOOD AUTHORIZED SERVICE CENTERS IN MILITARY MARKET**

**JAPAN:**

Yokota
Kenwood Rep.; c/o
Yokota BX, JAAX AAFES-PAC,
APO San Francisco 96328

**Zama**

Kenwood Rep.; c/o
Zama PX, JAAX AAFES-PAC,
APO San Francisco 96343

**Misawa**

Kenwood Rep.; c/o
Misawa BX, JAAX AAFES-PAC,
APO San Francisco 96519

**Yokosuka**

Kenwood Rep.; c/o
A-33, Yokosuka NEX No. 260-010
FPO Seattle 98760

**Atsugi**

Kenwood Rep.; c/o
Atsugi NEX No. 260-020 FPO Seattle 98767

**Iwakuni**

Kenwood Rep.; c/o
Marine Corps Exchange, Marine Corps Air Station,
FPO Seattle 98764

**Sasebo**

Sasebo NEX;
Navy Exchange 260-040
F.A. Box 115 FPO Seattle 98766

**Okinawa**

Kenwood Rep.; c/o
OWAX, AAFES-PAC, APO San Francisco 96230

**KOREA:**

Kenwood Rep.; c/o
KOAX Repair Shop, AAFES-PAC
DD-Camp Market, APO San Francisco 96488

**GUAM:**

Kenwood Rep.; c/o
Guam NEX No. 230-010,
FPO San Francisco 96630
Kenwood Rep.; c/o
GUAX, AAFES-PAC, APO San Francisco 96334

**U.S.A.:**

**Hawaii**

Kenwood Factory Service
99-394 Iwaeana St, Aiea, Hawaii 96701

**Alaska**

Vista Radio TV;
861 East Loop Road, Anchorage, Alaska 99501
Anchorage Commercial Electronics, Inc.;
1450 East 9th Ave., Anchorage, Alaska 99501

**In The Continental U.S.A.**

For Nearest Authorized Service Center;
Tel: 1-800-536-9663

**Kenwood Service U.S.A.**

Kenwood Factory Service;
P.O. Box 22745, 2201 East Dominguez Street,
Long Beach, California 90801-5745
Tel: (310) 639-5300

**EUROPE:**

Please inquire at the military resale outlets where you bought your Kenwood products, or KENWOOD ELECTRONICS DEUTSCHLAND GMBH; Rembrücker-Str. 15, 63150 Heusenstamm, Germany Tel: 49-06104-89010

**CANADA**

**KENWOOD ELECTRONICS CANADA INC.**

**KENWOOD WARRANTY**

KENWOOD ELECTRONICS CANADA INC. (hereinafter called "KENWOOD"), gives the following written warranty to the original customer of each new Kenwood product distributed in Canada by KENWOOD and purchased from a dealer authorized by KENWOOD.

KENWOOD warrants that each new Kenwood product, under normal use, is free from any defects, subject to the terms and conditions set forth below. If a defect should occur within the warranty period, repairs will be made free of charge for parts and labour when such defects are determined by KENWOOD or its' authorized service centres to be attributable to faulty materials or workmanship at time of manufacture. Please contact KENWOOD to confirm if a dealer or service centre is authorized by KENWOOD.

**WARRANTY PERIOD**

This Kenwood product is warranted for parts and labour for a period of one (1) year from the date of original purchase, lease or rental, except for products which are used in a professional or commercial application, which are warranted for a period of ninety (90) days for parts and labour and are subject to the terms and conditions of the warranty.

**WARRANTY EXCLUSIONS**

This warranty excludes:

- (a) Products purchased in a foreign country or purchased in Canada and taken to a foreign country.
(b) Products purchased from a dealer not authorized by KENWOOD.
(c) Products with the serial number defaced, altered or missing.
(d) Periodic check-ups which do not disclose any defects covered by this warranty.
(e) Defects resulting from disaster, accident, abuse, misuse, lightning, power surges, neglect or lack of periodic maintenance, unauthorized modification or failure to follow instructions in the owner's manual.
(f) Defects or damage as a result of repairs performed by a person or party not authorized by KENWOOD.
(g) Defects resulting from the use of parts or devices that do not conform to KENWOOD specifications.
(h) Damage or deterioration occurring to any exterior finishes, cosmetic parts, tape heads, adaptors, antennas, cables, tapes, discs or faults or damage caused by defective or leaking batteries.
(i) Defects or damage occurring during shipping (claims should be presented to the shipping company).
(j) Product voltage and /or line frequency conversions.
(k) Product installation or removal charges.

**TO OBTAIN WARRANTY SERVICE**

Should your Kenwood product require warranty service, deliver it to any authorized KENWOOD service centre and present the original copy of your bill of sale and this warranty card as proof of warranty, or send your product fully insured and freight prepaid to the nearest authorized KENWOOD service centre. To avoid possible shipping damage, make sure the product is properly packed. Include a copy of your original bill of sale and this warranty card as proof of warranty along with your name, home and /or work telephone numbers, a complete return address and a detailed description of the fault(s). Products repaired within warranty will be returned freight prepaid to destinations within Canada. The customer is responsible for all freight and related costs for the return of product(s) to destinations outside Canada.

**ENTIRE WARRANTY**

This warranty constitutes the entire written warranty given by KENWOOD. No person, party, dealer or service centre or their agents or employees are authorized to extend or enlarge this warranty on behalf of KENWOOD by any written or verbal statement or advertisement or promotion, including any extended warranty program or plan that may be offered by the dealer or service centre, unless approved in writing by KENWOOD.

**DISCLAIMER**

KENWOOD disclaims any responsibility for loss of time or use of the product or any other indirect, incidental or consequential damage to other products or goods, inconvenience or commercial loss.

**NOTICE TO CONSUMER**

The provisions contained in this written warranty are not intended to limit, modify, take away, disclaim or exclude any warranties or rights you may have which are set forth in any applicable provincial or federal laws or legislation.

**IMPORTANT**

This warranty card by itself is not considered by KENWOOD as a valid proof of purchase. When applying for warranty repairs, you must present the original copy of your bill of sale and this warranty card as proof of warranty, so we recommend that they be kept in a safe place, should they be required in the future.

KENWOOD ELECTRONICS CANADA INC.
6070 Kestrel Road, Mississauga, Ontario, Canada L5T 1S8
Tel.: (905) 670-7211
Fax: (905) 670-7248

**ATTENTION**

This card and receipt (or invoice) are necessary to purchase a new panel in case of theft or damage.

**GARANTIE KENWOOD**

KENWOOD ELECTRONICS CANADA INC. (ci-après appelée "KENWOOD"), donne par écrit la garantie suivante à l'acheteur original de chaque nouveau produit Kenwood distribué au Canada par KENWOOD et acheté à un concessionnaire autorisé par KENWOOD.

KENWOOD garantit, sous réserve des termes et des conditions énoncés ci-dessous, que chaque nouveau produit Kenwood, dans des conditions d'emploi normales, est exempt de tous défauts. Si l'un défaut se produit pendant la période de garantie, KENWOOD s'engage à assumer le coût des pièces défectueuses et de la main-d'oeuvre nécessaire pour effectuer les réparations pourvu que de tels défauts sont attribuables à des pièces défectueuses employées lors de la fabrication du produit Kenwood ou à la main-d'oeuvre tel qu'établi par KENWOOD ou par l'un de ses centres de service autorisés. Appelez KENWOOD pour vérifier si un concessionnaire ou un centre de service est autorisé par KENWOOD.

**PÉRIODE DE GARANTIE**

Les pièces et la main-d'oeuvre nécessaires pour la réparation des produits Kenwood sont garanties pendant la période d'un (1) an à compter de la date d'achat, de bail ou de location originale, sauf dans les cas où les produits Kenwood sont employés dans un but professionnel ou commercial, où la garantie des pièces et de la main-d'oeuvre demeure en vigueur pendant une période de quatre-vingt-dix (90) jours sous réserve des termes et des conditions de la garantie.

**EXCLUSIONS DE GARANTIE**

Cette garantie ne couvre pas:

- (a) les produits achetés à l'étranger ou achetés au Canada et transportés à l'étranger;
(b) les produits achetés à un concessionnaire non autorisé par KENWOOD;
(c) les produits dont le numéro de série manque, a été effacé ou modifié;
(d) les services d'entretien périodiques qui n'indiquent aucun défaut couvert par cette garantie;
(e) les défauts causés par les désastres, les accidents, les abus, les emplois incorrects, les éclairs, les surtensions de courant, les manques de soins ou d'entretiens périodiques, les modifications non autorisées ou les manques de respect du mode d'emploi;
(f) les défauts ou les dommages causés lors de réparations effectuées par une personne ou par une partie non autorisée par KENWOOD;
(g) les défauts causés par l'emploi de pièces ou de dispositifs qui ne se conforment pas aux exigences de KENWOOD;
(h) les finitions extérieures, les pièces cosmétiques, les têtes de bandes, les adaptateurs, les antennes, les câbles, les bandes, les disques endommagés ou dépolis, ni les défauts ou dommages causés par des pièces défectueuses ou qui fuient;
(i) les défauts ou dommages qui se produisent pendant l'expédition des produits Kenwood (On devrait déposer de telles réclamations auprès des compagnies de transport);
(j) les conversions de tension et/ou de fréquence du produit;
(k) les frais d'installation ou d'enlèvement du produit.

**COMMENT OBTENIR DU SERVICE SOUS GARANTIE**

Au cas où un service sous garantie de votre produit Kenwood s'avère nécessaire, veuillez livrer le produit à n'importe quel centre de service KENWOOD et présenter la copie originale du contrat de vente et cette carte de garantie en tant que preuve de garantie ou veuillez faire parvenir votre produit assuré et port payé au centre de service KENWOOD autorisé le plus proche. Pour éviter toutes possibilités de dommages pendant le transport, veuillez bien emballer le produit. Veuillez inclure une copie du contrat de vente original et cette carte de garantie en tant que preuve de garantie aussi bien que votre nom, numéros de téléphone au poste de travail et/ou à domicile, votre adresse et une description détaillée des défauts. Les produits sous garantie réparés seront retournés port payé aux destinations à l'intérieur du Canada. Le consommateur sera responsable de tous frais de transport et d'autres frais qui s'y rapportent pour faire expédier les produits à destinations à l'extérieur du Canada.

**L'ENTÈRE GARANTIE**

Cette garantie représente l'entière garantie donnée par écrit par KENWOOD. KENWOOD ne se tient aucunement responsable de toutes extensions ni de toutes augmentations de cette garantie faites ou entreprises par toutes personnes, parties, concessionnaires ou centres de service ou par leurs agents ou employés au nom de KENWOOD au moyen d'affirmations verbales ou écrites, d'annonces ou de promotions, y inclus tous programmes ou plans de garantie étendus que puissent offrir les concessionnaires ou les centres de service, à moins que KENWOOD n'y ait consenti par écrit d'avance.

**RENONCIATION**

KENWOOD renonce à toutes responsabilités de perte de temps, d'emploi du produit, de tous dommages indirects ou accessoires causés à d'autres produits ou biens, de tous inconvénients ou de toutes pertes commerciales.

**AVIS AUX CONSOMMATEURS**

Les stipulations contenues dans la présente garantie écrite n'ont pas pour but de limiter, de modifier, de diminuer, de rejeter ni d'exclure d'autres garanties ni droits énoncés dans n'importe quelles lois ou législations provinciales ou fédérales.

**IMPORTANT**

KENWOOD ne considère pas cette garantie toute seule comme étant une preuve d'achat valide. Lorsqu'on demande du service sous garantie, il faudra présenter la copie originale du contrat de vente aussi bien que cette carte de garantie en tant que preuve de garantie. On recommande de les conserver dans un lieu sûr au cas où elles s'avéreraient nécessaires à l'avenir.

KENWOOD ELECTRONICS CANADA INC.
6070 Kestrel Road, Mississauga, Ontario, Canada L5T 1S8
Téléphone: (905) 670-7211
Télexcopieur: (905) 670-7248

**ATTENTION**

La carte de garantie et la preuve d'achat (ou la facture) sont nécessaires à l'achat d'une nouvelle façade détachable en cas de dommages ou de vol.

The warranty will only be honoured in the country in which the unit was originally purchased.

## EXPRESS WARRANTY STATEMENT FOR CAR STEREO AND PERSONAL AUDIO COMPONENTS

KENWOOD ELECTRONICS AUSTRALIA PTY. LTD. is proud of the quality and workmanship of its audio equipment. This unit has been properly designed, tested and inspected before it was shipped to you. If properly installed and operated in accordance with instructions furnished, it should give optimum reliable performance.

### SCOPE OF EXPRESS WARRANTY

Each of the KENWOOD brand products is expressly warranted under normal installation and use against defects in material and workmanship. During the express warranty period, KENWOOD ELECTRONICS AUSTRALIA PTY. LTD. will provide to any KENWOOD Authorised Service Centre in Australia free of charge both parts and labour necessary to correct any defect in material or workmanship. However, the exclusions noted under the heading "CONDITIONS OF THE EXPRESS WARRANTY" are not covered by this express warranty.

### EXPRESS WARRANTY PERIOD

The KENWOOD brand car stereo and personal audio components are expressly warranted for a period of **ONE YEAR** from the date of the original purchase.

### CONDITIONS OF THE EXPRESS WARRANTY

When requesting service under KENWOOD express warranty record, together with a valid purchase docket must be presented to an authorised KENWOOD Service Centre with your equipment.

The following are not covered by this express warranty:

- Voltage conversions.
- Cabinets, grilles, other exterior finishes, belts, tape heads, and other non-durable parts and accessories.
- Any fault caused by faulty installation, water damage, the vehicle (including its electrical system) or connection to an incorrect power supply.
- Periodic check-ups which do not disclose any defects covered by the warranty.
- Units on which the serial number has been defaced, modified or removed.
- Damage or deterioration:
  - Resulting from installation and/or removal of the product.
  - Resulting from accident, misuse, abuse, neglect, unauthorised product modification or failure to follow instructions contained in the Owner's Manual.
  - Resulting from repair by anyone not authorised by KENWOOD.
  - Resulting from installation of parts or accessories that do not conform to the quality or specifications of the original parts or accessories.
  - Occurring during shipment (claims must be presented to shipper).
- Damaged magnetic tapes.
- Installation and removal charges are not covered.
- This express warranty excludes shipping or delivery charges to or from an authorised KENWOOD Service Centre.
- The benefits conferred by this express warranty are in addition to all other rights and remedies in respect of the product which the consumer has under the Trade Practices Act and/or other State or Territory Laws.

### EXCLUSION OF CERTAIN DAMAGES

KENWOOD's liability for any defective product is limited to the repair or replacement of said product at our option, and shall not include damages of any kind, whether incidental, consequential or otherwise.

### PROCEDURE WHEN REQUESTING SERVICE UNDER THE WARRANTY

- Make your equipment available, with this warranty record and purchase docket attached, to the dealer from whom you made the purchase, or the nearest authorised KENWOOD Service Centre, or ship your equipment in its original packaging, or equivalent, fully insured and shipping charges pre-paid, to the authorised KENWOOD Service Centre.
- Attach detailed description of the problem encountered, including details of any interconnections made to associated equipment.
- Make sure you recover this card, your purchase docket and repair docket when accepting the equipment back after repair.

### IMPORTANT NOTICE

- Proper maintenance and use are important to the performance level of all KENWOOD brand products. Therefore, you should read your instruction manual.
- Retain your purchase docket together with this warranty record in a safe place, and present them both to prove your eligibility for warranty work.
- We recommend that you keep all the original packaging as it provides the best protection you can have for transportation of your equipment in the future.
- Location of nearest KENWOOD Service Centre will be sent upon request.
- This warranty is in addition to and not in place of such rights at the owner may have at law.

KENWOOD ELECTRONICS AUSTRALIA PTY. LTD.  
16 GIFFNOCK AVENUE, CENTRECOURT ESTATE, NORTH RYDE,  
N.S.W. 2113, AUSTRALIA  
TEL. (02) 8879-2222  
FAX. (02) 8879-2233

### ATTENTION

This card and receipt (or invoice) are necessary to purchase a new panel in case of theft or damage.

The warranty will only be honoured in the country in which the unit was originally purchased.

## EXPRESS WARRANTY STATEMENT FOR CAR STEREO AND PERSONAL AUDIO COMPONENTS

KENWOOD ELECTRONICS (MALAYSIA) SDN. BHD. is proud of the quality and workmanship of its audio equipment. This unit has been properly designed, tested and inspected before it was shipped to you. If properly installed and operated in accordance with instructions furnished, it should give optimum reliable performance.

### SCOPE OF EXPRESS WARRANTY

Each of the KENWOOD brand products is expressly warranted under normal installation and use against defects in material and workmanship. During the express warranty period, KENWOOD ELECTRONICS (MALAYSIA) SDN. BHD. will provide to any KENWOOD Authorised Service Centre in Malaysia free of charge both parts and labour necessary to correct any defect in material or workmanship. However, the exclusions noted under the heading "CONDITIONS OF THE EXPRESS WARRANTY" are not covered by this express warranty.

### EXPRESS WARRANTY PERIOD

The KENWOOD brand car stereo and personal audio components are expressly warranted for a period of **ONE YEAR** from the date of the original purchase.

### CONDITIONS OF THE EXPRESS WARRANTY

When requesting service under KENWOOD express warranty record, together with a valid purchase docket must be presented to an authorised KENWOOD Service Centre with your equipment.

The following are not covered by this express warranty:

- Voltage conversions.
- Cabinets, grilles, other exterior finishes, belts, tape heads, and other non-durable parts and accessories.
- Any fault caused by faulty installation, water damage, the vehicle (including its electrical system) or connection to an incorrect power supply.
- Periodic check-ups which do not disclose any defects covered by the warranty.
- Units on which the serial number has been defaced, modified or removed.
- Damage or deterioration:
  - Resulting from installation and/or removal of the product.
  - Resulting from accident, misuse, abuse, neglect, unauthorised product modification or failure to follow instructions contained in the Owner's Manual.
  - Resulting from repair by anyone not authorised by KENWOOD.
  - Resulting from installation of parts or accessories that do not conform to the quality or specifications of the original parts or accessories.
  - Occurring during shipment (claims must be presented to shipper).
- Damaged magnetic tapes.
- Installation and removal charges are not covered.
- This express warranty excludes shipping or delivery charges to or from an authorised KENWOOD Service Centre.
- The benefits conferred by this express warranty are in addition to all other rights and remedies in respect of the product which the consumer has under Sales of Goods Act 1957 (Revised 1989).

### EXCLUSION OF CERTAIN DAMAGES

KENWOOD's liability for any defective product is limited to the repair or replacement of said product at our option, and shall not include damages of any kind, whether incidental, consequential or otherwise.

### PROCEDURE WHEN REQUESTING SERVICE UNDER THE WARRANTY

- Make your equipment available, with this warranty record and purchase docket attached, to the dealer from whom you made the purchase, or the nearest authorised KENWOOD Service Centre, or ship your equipment in its original packaging, or equivalent, fully insured and shipping charges pre-paid, to the authorised KENWOOD Service Centre.
- Attach detailed description of the problem encountered, including details of any interconnections made to associated equipment.
- Make sure you recover this card, your purchase docket and repair docket when accepting the equipment back after repair.

### IMPORTANT NOTICE

- Proper maintenance and use are important to the performance level of all KENWOOD brand products. Therefore, you should read your instruction manual.
- Retain your purchase docket together with this warranty record in a safe place, and present them both to prove your eligibility for warranty work.
- We recommend that you keep all the original packaging as it provides the best protection you can have for transportation of your equipment in the future.
- Location of nearest KENWOOD Service Centre will be sent upon request.
- This warranty is in addition to and not in place of such rights at the owner may have at law.

KENWOOD ELECTRONICS (MALAYSIA) SDN. BHD.  
#4.01 LEVEL 4, WISMA ACADEMY, LOT 4A JALAN19/1, 46300 PETALING JAYA,  
SELANGOR, MALAYSIA  
TEL. (03) 7954-8333  
FAX. (03) 7954-1233

### ATTENTION

This card and receipt (or invoice) are necessary to purchase a new panel in case of theft or damage.

O fabricante garante o produto identificado na Nota Fiscal de venda ao consumidor contra qualquer defeito de fabricação ou de matéria-prima durante o período de garantia. Esta garantia é válida no território brasileiro, condicionado ao uso correto do aparelho conforme o manual de instruções.

### PERÍODO DE GARANTIA

Este produto é garantido pelo prazo de 01 (um) ano, incluindo o período estabelecido por lei, a partir da data de aquisição, comprovada mediante a apresentação da respectiva Nota Fiscal de venda ao consumidor final.

Eventuais reparos realizados no período de garantia não implicam na dilatação do seu prazo.

### EXCLUSÃO DA GARANTIA

- Produtos com o número de série ou certificado de garantia rasurados, adulterados ou ilegíveis;
- Defeitos resultantes de acidentes (quedas, batidas e etc), uso em desacordo com o manual de instruções, má utilização, ligação à fonte de tensão diferente da especificada no Manual de Instruções, modificações não autorizadas;
- Danos causados por agentes da natureza (Ex: Chuvas, raios, maresias, enchentes e etc);
- Defeitos ou danos em decorrência de consertos realizados por pessoas não autorizadas;
- Defeitos ou danos resultantes do uso de peças ou dispositivos não conformes às especificações da Kenwood;
- Danos ou deteriorações aos acabamentos externos, partes cosméticas, cabos, adaptadores, antenas, fitas, cabeças gravadoras, CDs ou danos causados por pilhas defeituosas ou com vazamento;
- Defeitos ou danos devido ao transporte (reclamações devem ser feitas junto à empresa transportadora);
- Qualquer outra causa que não esteja relacionada a defeitos de matéria-prima e de fabricação;
- Danos causados por tentativa de roubo ou furto;
- Danos causados por uso de CDs de má qualidade.

### CONSERTO EM GARANTIA

É indispensável a apresentação deste Certificado de Garantia devidamente preenchido, acompanhado da respectiva Nota Fiscal de compra do produto.

### O QUE NÃO É COBERTO PELA GARANTIA

Instalação e remoção do produto, despesas de frete, seguro e embalagem são de responsabilidade do proprietário.

JVC KENWOOD DO BRASIL COMERCIO DE ELECTRONICOS LTDA.  
Tel: 0800-7717270  
www.kenwood.com.br

### ATENÇÃO

Em caso de dano ou perda do painel frontal, este Certificado de Garantia e a Nota Fiscal de compra serão requisitados para a aquisição de um novo painel.

### Уважаемый покупатель!

Благодарим Вас за покупку этого изделия марки Kenwood и надеемся, что оно Вам понравится. В случае, если Ваше изделие будет нуждаться в гарантийном обслуживании, пожалуйста, обращайтесь в Авторизованные Сервисные Центры Kenwood (далее АСЦ) или в магазин, где Вы приобрели изделие Kenwood. Список сервисных центров можно получить у продавца или на сайте: <http://www.kenwood-rus.ru/support/service/>

Данный гарантийный талон действителен только в той стране, где изначально был куплен аппарат. Настоящая гарантия будет предоставлена в дополнение к правам потребителя и не уменьшает никакие другие права, которые могут быть предоставлены потребителю законом о защите прав потребителей и другими соответствующими законами.

Без предъявления настоящего гарантийного талона мы не сможем обеспечить гарантийное обслуживание. Просим Вас сохранять Ваш сертификат вместе с чеком покупки на весь период гарантийного обслуживания.

На основании этой потребительской гарантии Kenwood гарантирует отсутствие в изделии дефектов в материалах и работе сроком на 1 (один) год, начиная с даты первоначальной покупки. Если в течение этого гарантийного срока в изделии обнаружатся дефекты в материалах или работе, АСЦ Kenwood бесплатно отремонтирует это изделие и заменит его дефектные части на приведенных ниже условиях. Также мы оставляем за собой право замены изделия, если его ремонт экономически нецелесообразен.

### Гарантийные условия

- Ремонт дефектного изделия осуществляется по предъявлению потребителем четко, правильно и полностью заполненного гарантийного талона, с внесенными в него следующими данными:
  - Фамилии и адреса покупателя;
  - Полного названия и адреса дилера у кого был приобретен аппарат;
  - Наименования модели и серийного номера аппарата;
  - А также кассового и товарного чека или любого другого документа, подтверждающего покупку изделия. Без предъявления данного талона, в случае отсутствия в нем полной информации или при наличии каких-либо изменений в талоне, претензии к качеству изделия не принимаются и гарантийный ремонт не производится.
- Фирма Kenwood уделяет большое внимание качеству выпускаемой продукции. При использовании ее для личных (бытовых) нужд с соблюдением правил эксплуатации срок ее службы может значительно превысить официальный срок службы, установленный в соответствии с действующим законодательством о правах потребителей. Адаптация и изменения с обчной сферы применения изделия, указанной в инструкции по эксплуатации настоящей гарантии не покрываются.
- Настоящая гарантия не распространяется на следующие:
  - ремонт предусмотрен Инструкцией по эксплуатации или является частью обычного технического обслуживания, включая периодические проверки, чистку аудио/видео головок;
  - ремонт, произведенный не уполномоченными на то сервисными центрами или другими лицами или организациями не имеющими юридических полномочий производить ремонт;
  - изделие вышло из строя в результате механического повреждения, воздействия на него домашних животных или насекомых, некачественной установки или неправильного использования;
  - повреждение изделия вызванное несчастным случаем, механическим повреждением, ударом молнии, затоплением, пожаром, неправильной вентиляции, колебаний напряжения и иных причин, находящихся вне контроля Kenwood;
  - громкоговорители поврежденные колебанием напряжения не соответствующим спецификации, и повреждения или потеря программного обеспечения или съемных носителей, не являющихся частью изделия Kenwood;
  - расходные материалы нуждающиеся в замене, такие как (но не ограничиваясь): аудио/видеоголовки, все виды батарей, шнуры, разъемов и прочих деталей, обладающих ограниченным сроком использования;
  - если серийный номер или номер модели на изделии изменен, удален, стерт или неразборчивый.

Настоящая гарантия распространяется только на официально поставляемые изделия.

Настоящая гарантия действительна только для изделий используемых для личных бытовых нужд, и не распространяется на изделия, которые используются для коммерческих, промышленных или профессиональных целей.

ООО «КЕНВУД ЭЛЕКТРОНИКС СНГ»  
www.kenwood-rus.ru

### ВНИМАНИЕ

Гарантийный талон и чек (товарный или кассовый) необходимы для приобретения новой панели в случае ее потери/кражи или повреждения.