

# **KICKER®**

**Owner's Manual**  
**Manual del Propietario**  
**Manuel d'utilisatio**  
**Benutzerhandbuch**

## CompVX-Series Subwoofers

*select language*

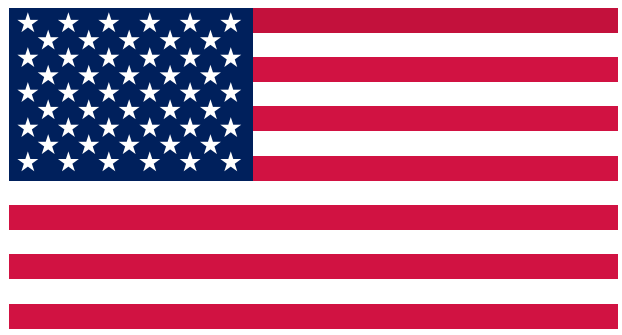

*seleccione  
el idioma*

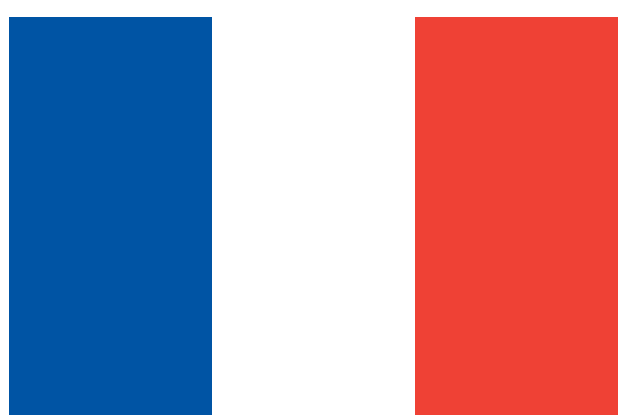

*choisir la  
langue*



*sprache  
auswählen*

# Contents

---

Overview .....	3
Specifications .....	4
Installation .....	5
Wiring Configuration.....	5
Box Building Notes .....	7
Sealed Enclosures.....	10
Vented Enclosures.....	12
Warranty .....	13
Garantía   Garantie.....	48

# Overview

---

## **IMPORTANT SAFETY WARNING**

PROLONGED CONTINUOUS OPERATION OF AN AMPLIFIER, SPEAKER, OR SUBWOOFER IN A DISTORTED, CLIPPED OR OVER-POWERED MANNER CAN CAUSE YOUR AUDIO SYSTEM TO OVERHEAT, POSSIBLY CATCHING FIRE AND RESULTING IN SERIOUS DAMAGE TO YOUR COMPONENTS AND/OR VEHICLE. AMPLIFIERS REQUIRE UP TO 4 INCHES (10CM) OPEN VENTILATION. SUBWOOFERS SHOULD BE MOUNTED WITH AT LEAST 1 INCH (2.5CM) CLEARANCE BETWEEN THE FRONT OF THE SPEAKER AND ANY SURFACE. KICKER PRODUCTS ARE CAPABLE OF PRODUCING SOUND LEVELS THAT CAN PERMANENTLY DAMAGE YOUR HEARING! TURNING UP A SYSTEM TO A LEVEL THAT HAS AUDIBLE DISTORTION IS MORE DAMAGING TO YOUR EARS THAN LISTENING TO AN UNDISTORTED SYSTEM AT THE SAME VOLUME LEVEL. THE THRESHOLD OF PAIN IS ALWAYS AN INDICATOR THAT THE SOUND LEVEL IS TOO LOUD AND MAY PERMANENTLY DAMAGE YOUR HEARING. PLEASE USE COMMON SENSE WHEN CONTROLLING VOLUME.

The CVX Subs are a case study in what makes KICKER subwoofers the absolute best in the business. They feature the highest-power handling possible and with dual-voice coils give you all the wiring options you could want. The aluminum basket reduces weight while achieving higher heat dissipation than steel. Perimeter-venting is present as usual, but KICKER-quality means we need our products to go above and beyond. KICKER has now introduced our latest innovation of Forced-Air Cooling, which uses the excursion of the woofer to force out hot air while drawing in cool air. This results in a 20% reduction in heat, increasing the already industry-leading reliability of our subs. Get ready for signature KICKER bass, and make sure you're using these subwoofers with KICKER accessories and amps to get the best results.

# Specifications

	<b>CVX10</b>	<b>CVX12</b>	<b>CVX15</b>
Woofer [in, mm]	10, 25	12, 30	15, 38
Recommended Amplifier Power [Watts RMS]	300–600	375–750	500–1000
Peak Power Handling [Watts]	1200	1500	2000
Sensitivity [1W, 1m]	85.7	87.1	91.6
Rated Impedance [ $\Omega$ ]	2 or 4	2 or 4	2 or 4
Fs [Hz]	35.4	28.5	23.7
Xmax (Linear Excursion) [mm]	16.25	16.25	19
Re [ $\Omega$ ]	3.4	3.7	4.2
Qts	.403	.381	.216
Qms	10.754	10.098	7.521
Qes	.419	.396	.222
Vas [ft <sup>3</sup> , L]	.811, 22.99	2.04, 57.82	5.5, 156.71
Outer Frame Dimension [in, cm]	10-11/16, 27.1	12-9/16, 31.8	15-7/16, 39.2
Mounting Cutout [in, cm]	9-3/16, 23.3	11-1/16, 28	13-13/16, 35
Mounting Depth [in, cm]	5-15/16, 15.1	6-11/16, 16.9	8-1/2, 21.5
Frequency Response [Hz]	24–500	20–500	18–500

**Note:** All specifications and performance figures are subject to change. Please visit **[www.kicker.com](http://www.kicker.com)** for the most current information. To get the best performance from your new KICKER speakers, we recommend using genuine KICKER accessories and wiring. Please allow two weeks of break-in time for the speakers to reach optimum performance.

**Pro Tip:** You're a KICKER amplifier and a few cables away from a full system upgrade that will dominate any factory system! KICKER line of amplifiers make it easy to upgrade to solid bass with your existing or stock source unit. Also, ask your dealer about KICKER Speaker upgrades.

# Installation

---

## Wiring Configuration

CompVX-Series subwoofers are made with dual  $2\Omega$  or  $4\Omega$  voice coils. Both coils must be connected to a source of amplification. The Dual  $2\Omega$  will provide a  $1\Omega$  load wired in parallel or  $4\Omega$  load wired in series. The Dual  $4\Omega$  will provide a  $2\Omega$  load wired in parallel or  $8\Omega$  load wired in series. **Make sure your source unit or amplifier is rated at the correct ohm load for operation.**

The speaker wire should be kept away from sharp edges and avoid the possibility of getting pinched by the trunk. If a factory hole and grommet do not exist or are inaccessible, you must drill a hole through which to run the wire. Be careful not to drill into other wiring or existing mechanisms. Any time a wire is run through a hole, it is necessary to insert a rubber or plastic grommet to protect the wire from damage.



## Series Wiring

Dual  $2\Omega$  Voice Coils =  $4\Omega$  Load

Dual  $4\Omega$  Voice Coils =  $8\Omega$  Load

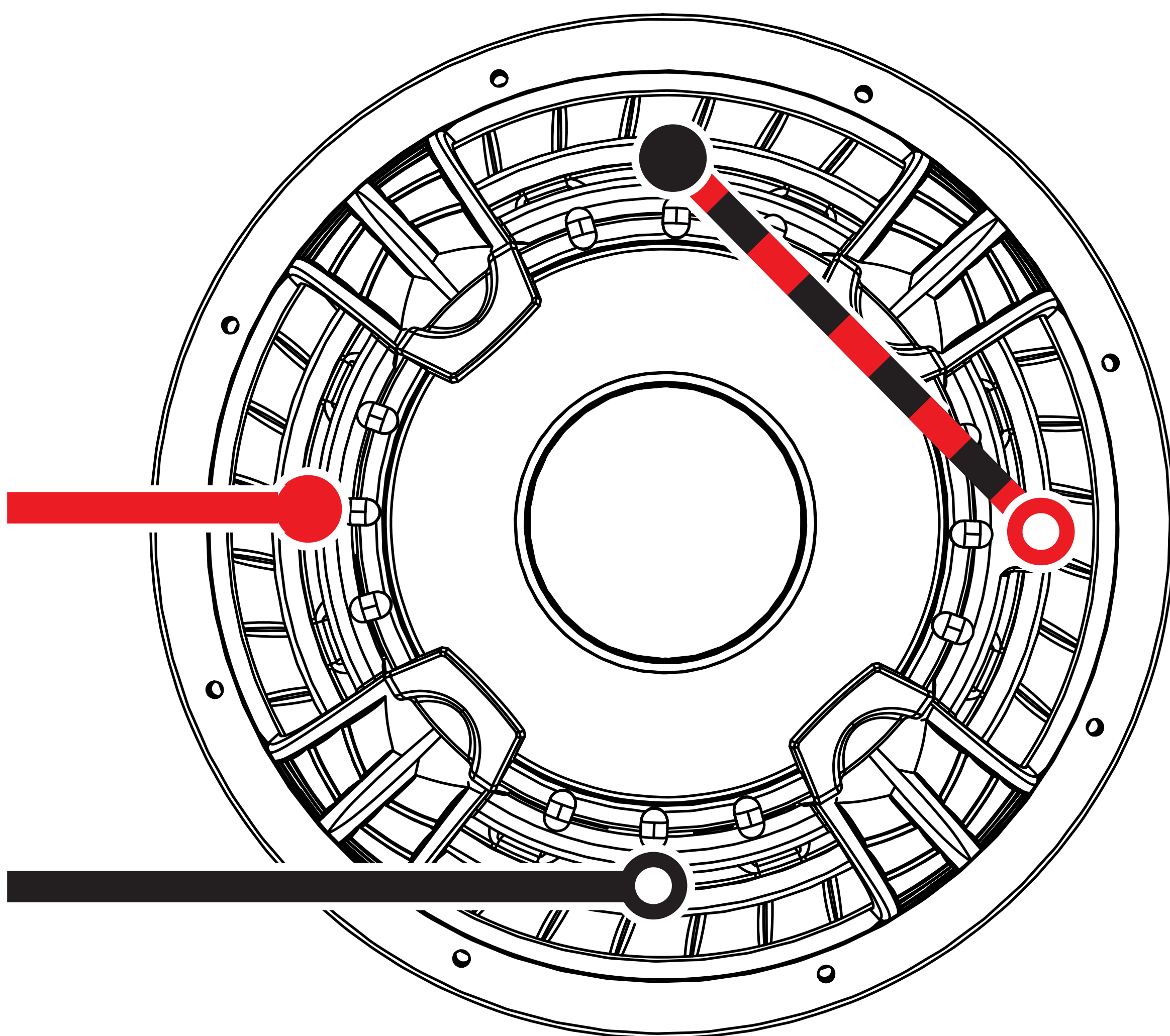

## Parallel Wiring

Dual  $2\Omega$  Voice Coils =  $1\Omega$  Load

Dual  $4\Omega$  Voice Coils =  $2\Omega$  Load

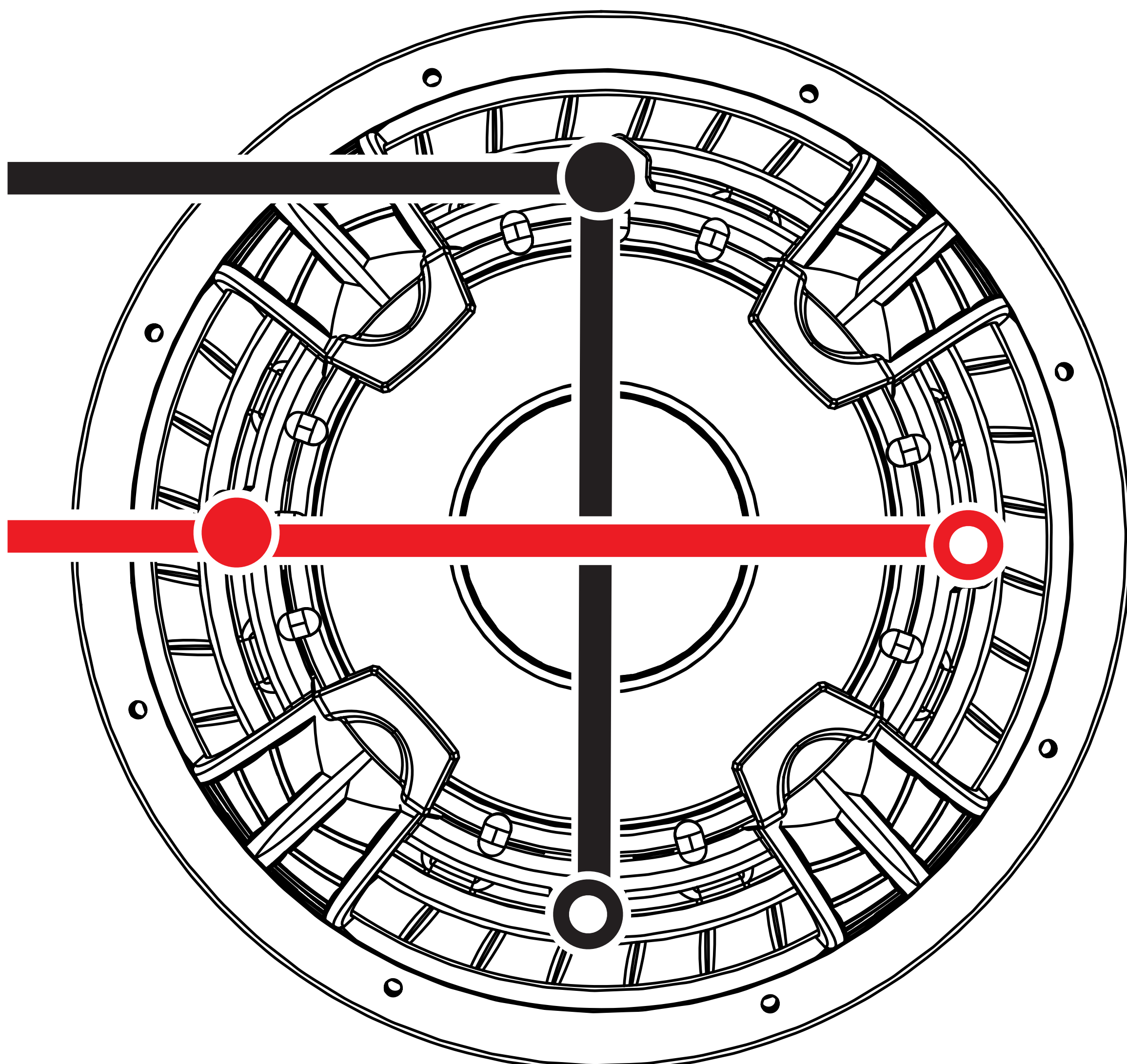

# Box Building Notes

Use 3/4" (1.9cm) or thicker MDF (medium density fiberboard) and seal the joints with silicone. Use the "template" inside your CompVX subwoofer's shipping carton to mark the mounting hole, then cut directly on the line. These designs need internal bracing. Add triangular bracing between each of the larger unsupported panels.

All the cubic feet (L) measurements in this manual include the displacement of the woofer. For the vented enclosures the displacement of the port must be calculated and added to the internal volume of the final design. Use the outer dimensions of the port and multiply "X x Y x Z", convert to cubic feet, for example the CompVX12 Vented Minimum design's external port dimensions are, using 3/4" (1.9cm) MDF:

$$(12.5" + 1.5" \text{ total MDF wall thickness}) \times (2.5" + 1.5" \text{ total MDF wall thickness}) \times (20") \times (1 \text{ ft}^3 / 1728 \text{ in}^3) = .65 \text{ ft}^3$$

Then, add this number to the internal volume of the enclosure.  $1.75 \text{ ft}^3 + .65 \text{ ft}^3 = 2.4 \text{ ft}^3$

Due to the necessary length of these ports, you may want to fold the port along the bottom and back walls. It will be impractical to use round ports for these designs.

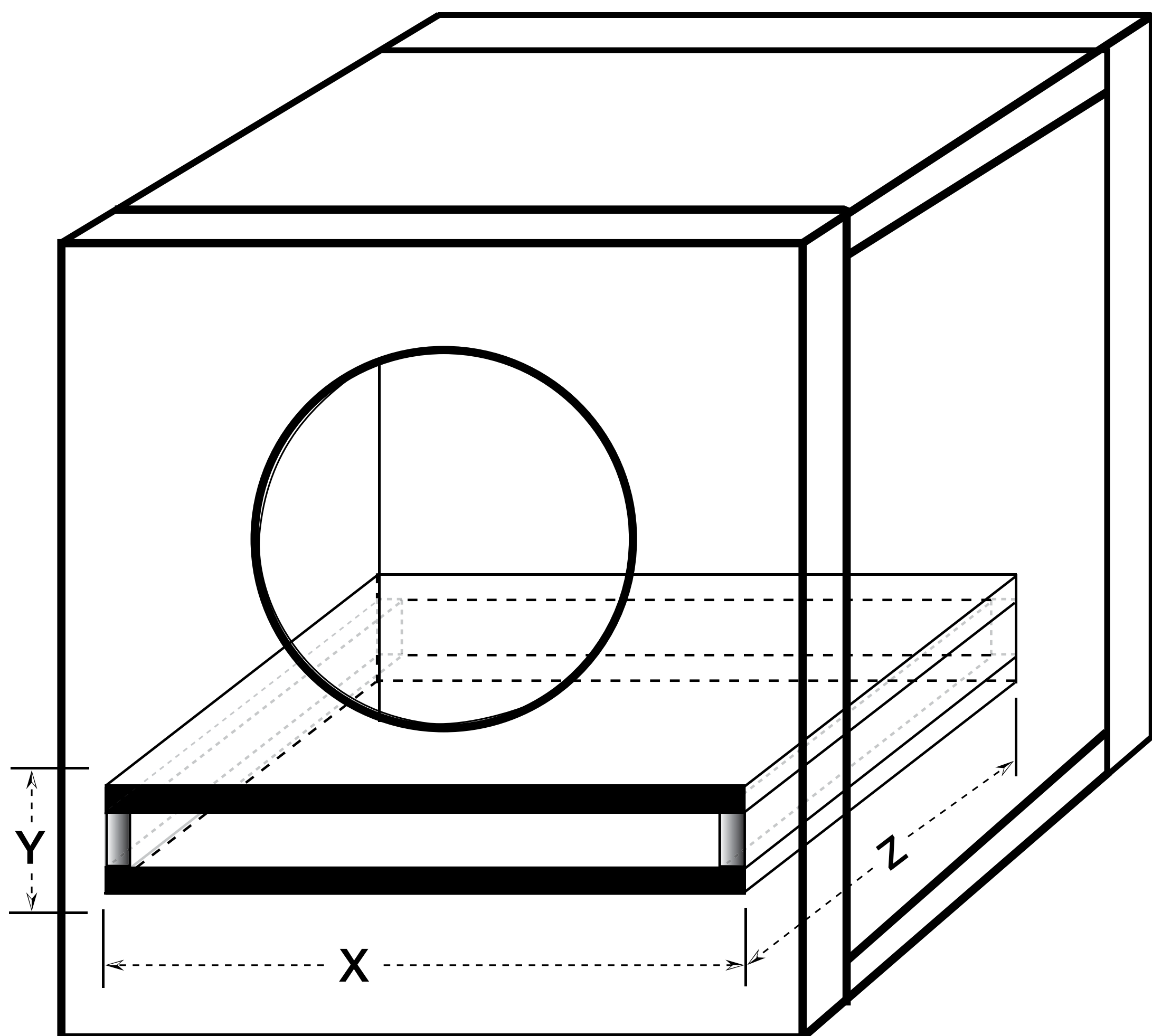

Do not install a port opening against a solid surface, such as an internal brace, back-panel or trunk wall, seat or interior panel of your vehicle. The port opening must remain unobstructed. Use the smallest dimension of the rectangular port as the minimum amount of space between the port opening and any solid surface to insure unrestricted airflow.

You can loosely fill your enclosure with poly-fil stuffing. Ported designs will require covering the end of the port (located inside the box) with grill cloth, chicken wire, or expanded metal to prevent the poly-fil from exiting the port. The use of poly-fil will slightly decrease efficiency, but will deepen and extend the low frequency output by making your subwoofer think it's in a bigger box.



Add triangular bracing between each of the larger unsupported panels.

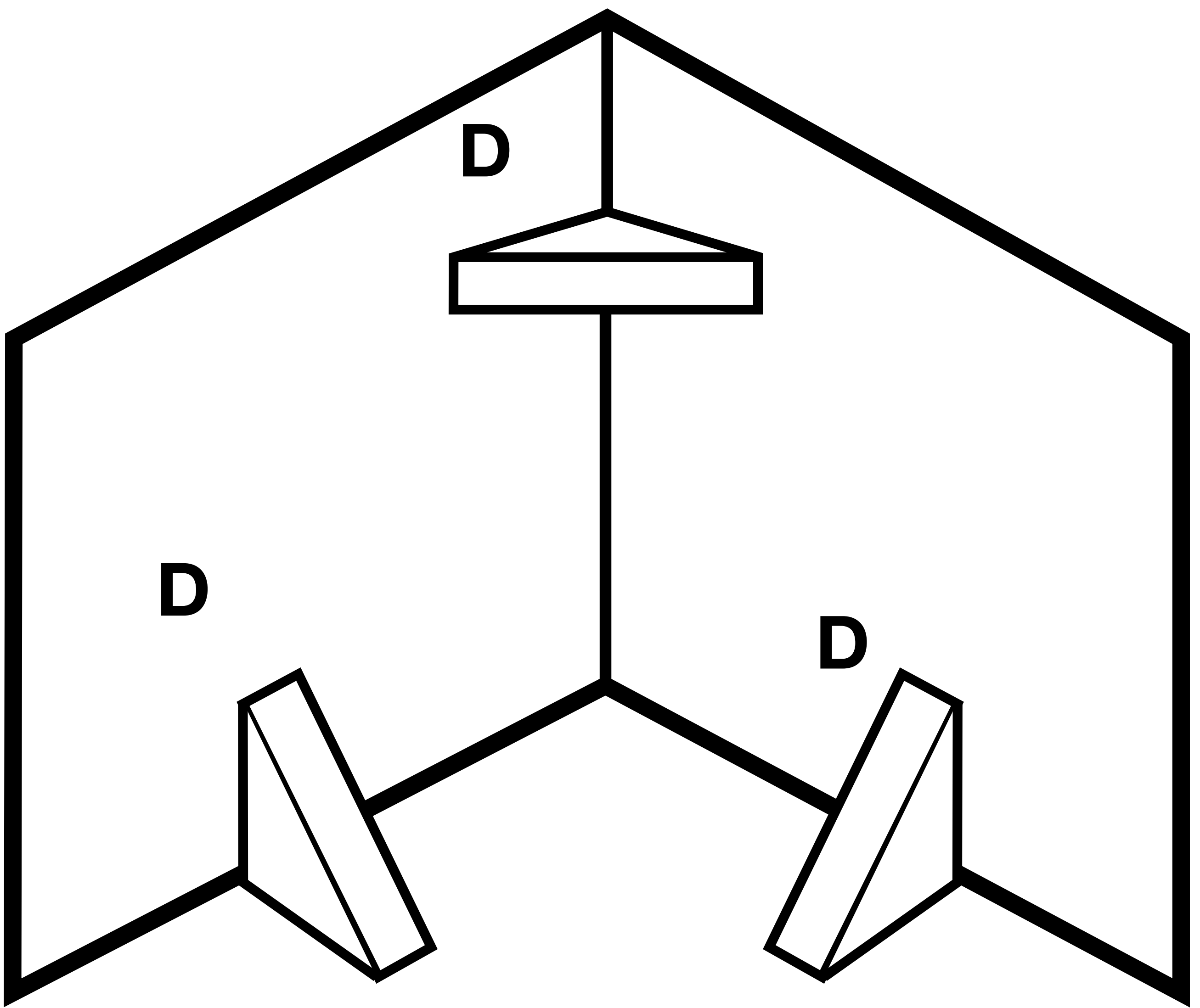

**CVX12, CVX15: D = 3" x 3" (8cm x 8cm)**

**CVX10: D = 2" x 2" (5cm x 5cm)**

For more advice on box building, refer to your Authorized Kicker Dealer, or click on the Support tab on the Kicker homepage, **[www.kicker.com](http://www.kicker.com)**. Please e-mail [support@kicker.com](mailto:support@kicker.com) or call Technical Support at (405) 624-8583 for specific or unanswered questions.

# Sealed Enclosures

These sealed enclosure designs give the smoothest response with increased energy at the lowest frequencies, 20 to 30Hz.

These designs deliver massive amounts of highly-accurate bass and can be driven with punishing levels of amplifier power.

The CompVX-Series high performance suspension system can operate in a larger sealed enclosure. This maximum enclosure volume application is ideal for SQ (ultra sound quality) installations. The Maximum enclosure generates a very flat response curve and extends the sub-bass response.

## Minimum Sealed

Model	Volume ft <sup>3</sup> (L)	Power Handling
<b>CVX10</b>	.8 (22.7)	600W RMS
<b>CVX12</b>	1 (28.3)	750W RMS
<b>CVX15</b>	1.8 (51)	1000W RMS

## Maximum Sealed

Model	Volume ft <sup>3</sup> (L)	Power Handling
<b>CVX10</b>	1.25 (35.4)	300W RMS
<b>CVX12</b>	2 (56.64)	300W RMS
<b>CVX15</b>	3 (85)	500W RMS

## Panel Dimensions for Minimum Sealed Enclosures using 3/4" (1.9cm) thick MDF:

	<b>CVX10</b>	<b>CVX12</b>	<b>CVX15</b>
Volume ft <sup>3</sup> [L]	.8 [22.7]	1 [28.3]	1.8 [51]
Panel A in. [cm]	13.5X13.5 [34.3X34.3]	14.5X14.5 [36.8X36.8]	17.25X17.25 [43.8X43.8]
Panel B in. [cm]	13.5X10.125 [34.3X25.7]	14.5X11 [36.8X27.9]	17.25X13.5 [43.8X34.3]
Panel C in. [cm]	12X10.125 [30.5X25.7]	13X11 [33X27.9]	15.75X13.5 [40X34.3]

CompVX-Series subwoofers perform well in any size sealed enclosure between the Minimum and Maximum volume recommendations. These systems will exhibit benefits of both designs. Overall, the system will sound more like the recommended enclosure design it is closest to in enclosure volume. These enclosure recommendations have been calculated with the airspace inside the enclosure and include the displacement of the woofer. All sealed-enclosure airspace should be filled to 50% loose poly-fil (polyester fiberfill) stuffing. Do not make the airspace greater than the SQ, maximum enclosure volume, recommendation.

# Vented Enclosures

These boxes are the enclosure of choice if space is not a problem and you want to get the most output and low frequency extension from your CompVX subwoofer. CompVX subwoofers will handle massive amounts of power in any of the recommended enclosures, minimum or maximum. The smaller enclosures are best for use in limited-space applications. The larger recommended enclosures will yield slightly more bass at the lowest frequencies.

<b>Vented Minimum</b>	<b>CVX10</b>	<b>CVX12</b>	<b>CVX15</b>
Box Volume, ft <sup>3</sup> [L]	1.25 [35.4]	1.75 [49.6]	3 [85]
Port Opening, in. x in. [cm x cm]	2X10.5 [5.1X26.7]	2.5X12.5 [6.4X31.8]	2.75X15.5 [7X39.4]
Port Length, in. [cm]	20 [50.8]	20 [50.8]	25.75 [65.4]
Power Handling, RMS	200	300	500
<b>Vented Maximum</b>	<b>CVX10</b>	<b>CVX12</b>	<b>CVX15</b>
Box Volume, ft <sup>3</sup> [L]	1.75 [49.6]	2.25 [63.7]	5 [142]
Port Opening, in. x in. [cm x cm]	2.5X10.5 [6.4X26.7]	3X12.5 [7.6X31.8]	3X15.5 [7.6X39.4]
Port Length, in. [cm]	20 [50.8]	20.5 [52.1]	22 [55.9]
Power Handling, RMS	500	700	900

The Vented Minimum design increases bass efficiency and fits in many space-limited applications. Although it is the smallest recommended ported enclosure, the output from 30 to 80 Hz will be considerably higher than that of any sealed box. The Vented Maximum design has even more output in this frequency band. The Maximum is the largest and most efficient enclosure design.



# Warranty

---

When purchased from an Authorized KICKER Dealer, KICKER warrants this product to be free from defects in material and workmanship under normal use for a period of ONE (1) YEARS from date of original purchase with receipt. If this product is identified as “Refurbished” or “B Goods”, the warranty is limited to a period of THREE (3) MONTHS from the date of original purchase. In all cases you must have the original receipt. Should service be necessary under this warranty for any reason due to manufacturing defect or malfunction during the warranty period, KICKER will repair or replace (at its discretion) the defective merchandise with equivalent merchandise. Warranty replacements may have cosmetic scratches and blemishes. Discontinued products may be replaced with more current equivalent products. This warranty is valid only for the original purchaser and is not extended to owners of the product subsequent to the original purchaser. Any applicable implied warranties are limited in duration to a period of the express warranty as provided herein beginning with the date of the original purchase at retail, and no warranties, whether express or implied, shall apply to this product thereafter. Some states do not allow limitations on implied warranties; therefore, these exclusions may not apply to you. This warranty gives you specific legal rights; however you may have other rights that vary from state to state.

## **WHAT TO DO IF YOU NEED WARRANTY OR SERVICE:**

Defective merchandise should be returned to your local Authorized Stillwater Designs (KICKER) Dealer for warranty service. Assistance in locating an Authorized Dealer can be found at [www.KICKER.com](http://www.KICKER.com) or by contacting Stillwater Designs directly. You can confirm that a dealer is authorized by asking to see a current authorized dealer window decal.

If it becomes necessary for you to return defective merchandise directly to Stillwater Designs (KICKER), call the KICKER Customer Service Department at (405) 624-8510 for a Return Merchandise Authorization (RMA) number. Package only the defective items in a package that will prevent shipping damage, and return to:

**Stillwater Designs**  
**3100 North Husband St**  
**Stillwater, OK 74075**

The RMA number must be clearly marked on the outside of the package. Please return only defective components. The return of functioning items increases your return freight charges. Non-defective items will be returned freight collect to you. For example, if a subwoofer is defective, only return the defective subwoofer, not the entire enclosure. Include a copy of the original receipt with the purchase date clearly visible, and a “proof-of-purchase” statement listing the Customer’s name, Dealer’s name and invoice number, and product purchased. Warranty expiration on items without proof-of-purchase will be determined from the type of sale and manufacturing date code. Freight must be prepaid; items sent freight-collect, or COD, will be refused.

## **WHAT IS NOT COVERED?**

This warranty is valid only if the product is used for the purpose for which it was designed. It does not cover:

- o Damage due to improper installation
- o Subsequent damage to other components
- o Damage caused by exposure to moisture, excessive heat, chemical cleaners, and/or UV radiation
- o Damage through negligence, misuse, accident or abuse. Repeated returns for the same damage may be considered abuse
- o Any cost or expense related to the removal or reinstallation of product
- o Speakers damaged due to amplifier clipping or distortion
- o Items previously repaired or modified by any unauthorized repair facility
- o Return shipping on non-defective items
- o Products with tampered or missing barcode labels
- o Products with tampered or missing serial numbers
- o Products returned without a Return Merchandise Authorization (RMA) number
- o Products purchased from an UNAUTHORIZED dealer
- o Freight Damage
- o The cost of shipping product to KICKER
- o Service performed by anyone other than KICKER

## **HOW LONG WILL IT TAKE?**

KICKER strives to maintain a goal of one-week service for all acoustics (subwoofers, midrange drivers, tweeters, crossovers, etc) returns. Delays may be incurred if lack of replacement inventory or parts is encountered. Failure to follow these steps may void your warranty. Any questions can be directed to the KICKER Customer Service Department at (405) 624-8510. Contact your International KICKER dealer or distributor concerning specific procedures for your country’s warranty policies.

# Garantía | Garantie

---

Contact your International KICKER dealer or distributor concerning specific procedures for your country's warranty policies.

Our goods come with guarantees that cannot be excluded under the **Australian Consumer Law**. You are entitled to a replacement or refund for a major failure and for compensation for any other reasonably foreseeable loss or damage. You are also entitled to have the goods repaired or replaced if the goods fail to be of acceptable quality and the failure does not amount to a major failure.

## **GARANTÍA INTERNACIONAL**      **Versión Español**

Comuníquese con su concesionario o distribuidor KICKER internacional para obtener información sobre procedimientos específicos relacionados con las normas de garantía de su país.

La frase “combustible para vivir la vida Livin’ Loud™ a todo volumen” se refiere al entusiasmo por la vida que la marca KICKER de estéreos de automóvil representa y a la recomendación a nuestros clientes de que vivan lo mejor posible (“a todo volumen”) en todo sentido. La línea de altavoces y amplificadores KICKER es la mejor del mercado de audio de automóviles y por lo tanto representa el “combustible” para vivir a todo volumen en el área de “estéreos de automóvil” de la vida de nuestros clientes. Recomendamos a todos nuestros clientes que obedezcan todas las reglas y reglamentos locales sobre ruido en cuanto a los niveles legales y apropiados de audición fuera del vehículo.

## **INTERNATIONALE GARANTIE**      **Deutsche Version**

Nehmen Sie mit Ihren internationalen KICKER-Fachhändler oder Vertrieb Kontakt auf, um Details über die Garantieleistungen in Ihrem Land zu erfahren.

Der Slogan “Treibstoff für Livin’ Loud” bezieht sich auf die mit den KICKER-Autostereosystemen assoziierte Lebensfreude und die Tatsache, dass wir unsere Kunden ermutigen, in allen Aspekten ihres Lebens nach dem Besten (“Livin’ Loud”) zu streben. Die Lautsprecher und Verstärker von KICKER sind auf dem Markt für Auto-Soundsysteme führend und stellen somit den “Treibstoff” für das Autostereoerlebnis unserer Kunden dar. Wir empfehlen allen unseren Kunden, sich bezüglich der zugelassenen und passenden Lautstärkepegel außerhalb des Autos an die örtlichen Lärmvorschriften zu halten.

## **GARANTIE INTERNATIONALE**      **Version Française**

Pour connaître les procédures propres à la politique de garantie de votre pays, contactez votre revendeur ou distributeur International KICKER.

L’expression “ carburant pour vivre plein pot “ fait référence au dynamisme de la marque KICKER d’équipements audio pour véhicules et a pour but d’encourager nos clients à faire le maximum (“ vivre plein pot “) dans tous les aspects de leur vie. Les haut-parleurs et amplificateurs KICKER sont les meilleurs dans le domaine des équipements audio et représentent donc pour nos client le “ carburant pour vivre plein pot “ dans l’aspect “ installation audio de véhicule “ de leur vie. Nous encourageons tous nos clients à respecter toutes les lois et réglementations locales relatives aux niveaux sonores acceptables à l’extérieur des véhicules.

P.O. Box 459

Stillwater, Oklahoma 74076

USA

(405) 624-8510

 **stillwaterdesigns**



# KICKER® CVX-Series Subwoofer

## Info Card | Tarjeta de Información | Carte Info | Infokarte



**IMPORTANT:** KICKER recommends a professional installation performed by authorized retailers. You are solely responsible for safely mounting and wiring your products.

**IMPORTANTE:** KICKER recomienda que se realice una instalación profesional con proveedores con licencia. Usted es el único responsable por la instalación segura y el cableado de sus productos.

**IMPORTANT :** KICKER recommande une installation professionnelle effectuée par des fournisseurs agréés. Vous êtes l'unique responsable du montage et du câblage de vos produits en toute sécurité.

**WICHTIG:** KICKER empfiehlt eine professionelle Montage durch lizenzierte Anbieter. Sie haben die alleinige Verantwortung für die sichere Montage und Verkabelung Ihrer Geräte.

If you have a problem  
with this product, prior to returning  
the product to the store,

Contact  
**KICKER Tech Support**

Call us at 800-256-KICK (5425),  
or contact us at [support@kicker.com](mailto:support@kicker.com)  
with any questions or problems.

Thank you for your  
KICKER purchase!  
U.S. Customers Only

Scan here for  
owner's manual

Escanee aquí para manual  
del Propietario



Scannen Sie hier nach  
benutzerhandbuch  
Scannez ici pour manuel  
d'utilisation

Thank you and congratulations on your purchase of the KICKER CVX-series Subwoofer! The CVX Subs are a case study in what makes KICKER subwoofers the absolute best in the business. They feature the highest-power handling possible and with dual-voice coils give you all the wiring options you could want. The aluminum basket reduces weight while achieving higher heat dissipation than steel. Perimeter-venting is present as usual, but KICKER-quality means we need our products to go above and beyond. KICKER has now introduced our latest innovation of Forced-Air Cooling, which uses the excursion of the woofer to force out hot air while drawing in cool air. This results in a 20% reduction in heat, increasing the already industry-leading reliability of our subs. Get ready for signature KICKER bass, and make sure you're using these subwoofers with KICKER accessories and amps to get the best results.

Sincerely  
Steve Irby  
President/CEO

Merci et félicitations pour votre achat du caisson de basses de la série KICKER CVX ! Les sous-marins CVX sont une étude de cas sur ce qui fait des subwoofers KICKER les meilleurs du marché. Ils offrent la gestion de puissance la plus élevée possible et avec des bobines à double voix, vous offrent toutes les options de câblage que vous pourriez souhaiter. Le panier en aluminium réduit le poids tout en assurant une plus grande dispersion de la chaleur que l'acier, en plus de la ventilation périmétrique, mais la qualité KICKER signifie que nous avons besoin de ces produits pour aller au-delà. KICKER a maintenant présenté sa dernière innovation de refroidissement à air forcé, qui utilise l'excursion du woofer pour expulser l'air chaud tout en aspirant de l'air frais. Cela se traduit par une réduction de 20 % de la chaleur, augmentant la fiabilité déjà à la pointe de l'industrie de nos sous-marins. Préparez-vous pour les basses signature KICKER, et assurez-vous d'utiliser ces subwoofers avec les accessoires et amplis KICKER pour obtenir les meilleurs résultats.

Cordialement,  
Steve Irby  
Président/PDG

¡Gracias y felicitaciones por su compra del subwoofer de la serie CVX de KICKER! Los CVX Subs son un caso de estudio de lo que hace que los subwoofers KICKER sean absolutamente los mejores en el negocio. Cuentan con el manejo de mayor potencia posible y con bobinas de voz duales que le brindan todas las opciones de cableado que pueda desear. La canasta de aluminio reduce el peso y logra una mayor dispersión del calor que el acero, además de la ventilación perimetral, pero la calidad KICKER significa que necesitamos que estos productos vayan más allá. KICKER ahora ha presentado nuestra última innovación de enfriamiento por aire forzado, que utiliza la excursión del woofer para forzar la salida del aire caliente mientras aspira aire frío. Esto da como resultado una reducción del 20 % en el calor, lo que aumenta la confiabilidad líder en la industria de nuestros subwoofers. Prepárese para los bajos característicos de KICKER y asegúrese de usar estos subwoofers con accesorios y amplificadores KICKER para obtener los mejores resultados.

Atentamente,  
Steve Irby  
Presidente/CEO

Vielen Dank und herzlichen Glückwunsch zum Kauf des KICKER Subwoofers der CVX-Serie! Die CVX Subs sind eine Fallstudie darüber, was KICKER-Subwoofer zu den absolut besten in der Branche macht. Sie verfügen über die höchstmögliche Belastbarkeit und bieten Ihnen mit Doppelschwingspulen alle Verkabelungsoptionen, die Sie sich wünschen können. Der Aluminiumkorb reduziert das Gewicht und erreicht gleichzeitig eine höhere Wärmeableitung als Stahl, zusätzlich zur Perimeterbelüftung, aber die KICKER-Qualität bedeutet, dass wir diese Produkte brauchen, um darüber hinauszugehen. KICKER hat jetzt unsere neueste Innovation der Zwangsluftkühlung vorgestellt, die die Auslenkung des Tieftöners nutzt, um heiße Luft herauszudrücken, während kühle Luft angesaugt wird. Dies führt zu einer Reduzierung der Wärme um 20 % und erhöht die bereits branchenführende Zuverlässigkeit unserer Subs. Machen Sie sich bereit für den charakteristischen KICKER-Bass und stellen Sie sicher, dass Sie diese Subwoofer mit KICKER-Zubehör und -Verstärkern verwenden, um die besten Ergebnisse zu erzielen.

Mit freundlichen Grüßen  
Steve Irby  
President/CEO

**IMPORTANT SAFETY WARNING!** PROLONGED CONTINUOUS OPERATION OF AN AMPLIFIER, SPEAKER, OR SUBWOOFER IN A DISTORTED, CLIPPED, OR OVER-POWERED MANNER CAN CAUSE YOUR AUDIO SYSTEM TO OVERHEAT, POSSIBLY CATCHING FIRE AND RESULTING IN SERIOUS DAMAGE TO YOUR COMPONENTS AND/OR VEHICLE. AMPLIFIERS REQUIRE UP TO 4 INCHES (10CM) OPEN VENTILATION. SUBWOOFERS SHOULD BE MOUNTED WITH AT LEAST 1 INCH (2.5CM) CLEARANCE BETWEEN THE FRONT OF THE SPEAKER AND ANY SURFACE. KICKER PRODUCTS ARE CAPABLE OF PRODUCING SOUND LEVELS THAT CAN PERMANENTLY DAMAGE YOUR HEARING! PLEASE USE COMMON SENSE WHEN CONTROLLING VOLUME.

**ADVERTENCIA IMPORTANTE DE SEGURIDAD:** LA OPERACIÓN PROLONGADA Y CONTINUA DE UN AMPLIFICADOR DE MANERA DISTORSIONADA O CORTADA PUEDE PROVOCAR QUE SU SISTEMA DE AUDIO SE SOBRECALIENTE CON LA POSIBILIDAD DE INCENDIARSE Y PROVOCAR DAÑOS GRAVES A SUS COMPONENTES O VEHÍCULO. LOS AMPLIFICADORES REQUIEREN UNA VENTILACIÓN ABIERTA DE HASTA 4 PULGADAS (10 CM). LOS SUBWOOFERS DEBEN MONTARSE CON UN ESPACIO DE AL MENOS 1 PULGADA (2.5 CM) ENTRE LA PARTE FRONTAL DEL ALTAVOZ Y CUALQUIER SUPERFICIE. LOS EXCITADORES KICKER SON CAPACES DE PRODUCIR NIVELES DE SONIDO QUE PUEDEN DAÑAR PERMANENTEMENTE EL OÍDO. SEA PRECAVIDO CUANDO CONTROLE EL VOLUMEN.

**AVERTISSEMENT DE SÉCURITÉ IMPORTANT :** UN FONCTIONNEMENT CONTINU ET PROLONGÉ D'UN AMPLIFICATEUR EN DISTORSION OU EN SATURATION PEUT PROVOQUER LA SURCHAUFFE DE VOTRE SYSTÈME AUDIO, UN POTENTIEL DÉPART D'INCENDIE ET SÉRIEUSEMENT ENDOMMAGER VOS COMPOSANTS ET/OU VOTRE VÉHICULE. LES AMPLIFICATEURS NÉCESSITENT UNE VENTILATION OUVERTE JUSQU'À 4 POUCES (10 CM). LES SUBWOOFERS DOIVENT ÊTRE MONTÉS AVEC UN ESPACE D'AU MOINS 1 POUCE (2.5 CM) ENTRE L'AVANT DE L'ENCEINTE ET TOUTE SURFACE. KICKER-TREIBER KÖNNEN EINEN SCHALLPEGEL ERZEUGEN, DER ZU PERMANENTEN GEHÖRSCHÄDEN FÜHREN KANN! SEIEN SIE BEI DER LAUTSTÄRKEEINSTELLUNG BITTE VERNÜFTIG.

**WICHTIGE SICHERHEITSWARNUNG:** DER ANHALTENDE, FORTLAUFENDE BETRIEB EINES VERSTÄRKERS IN ÜBERSTEUERTER ODER ABGEMACKTER WEISE KANN DAZU FÜHREN, DASS SICH DAS AUDIO-SYSTEM ÜBERHITZT UND IN BRAND GERÄT, WAS ZU EINER SCHWEREN BESCHÄDIGUNG DER KOMponentEN UND/ODER DES FAHRZEUGS FÜHREN KANN. VERSTÄRKER BENÖTIGEN EINE OFFENE BELÜFTUNG VON BIS ZU 10 CM. SUBWOOFER SOLLTEN MIT EINEM ABSTAND VON MINDESTENS 2,5 CM ZWISCHEN DER VORDERSEITE DES LAUTSPRECHERS UND JEDER OBERFLÄCHE MONTIERT WERDEN. LES HAUT-PARLEURS KICKER ONT LA CAPACITÉ DE PRODUIRE DES NIVEAUX SONORES POUVANT ENDOMMAGER L'OUÏE DE FAÇON IRRÉVERSIBLE ! RÉGLEZ LE VOLUME EN FAISANT PREVUE DE BON SENS.



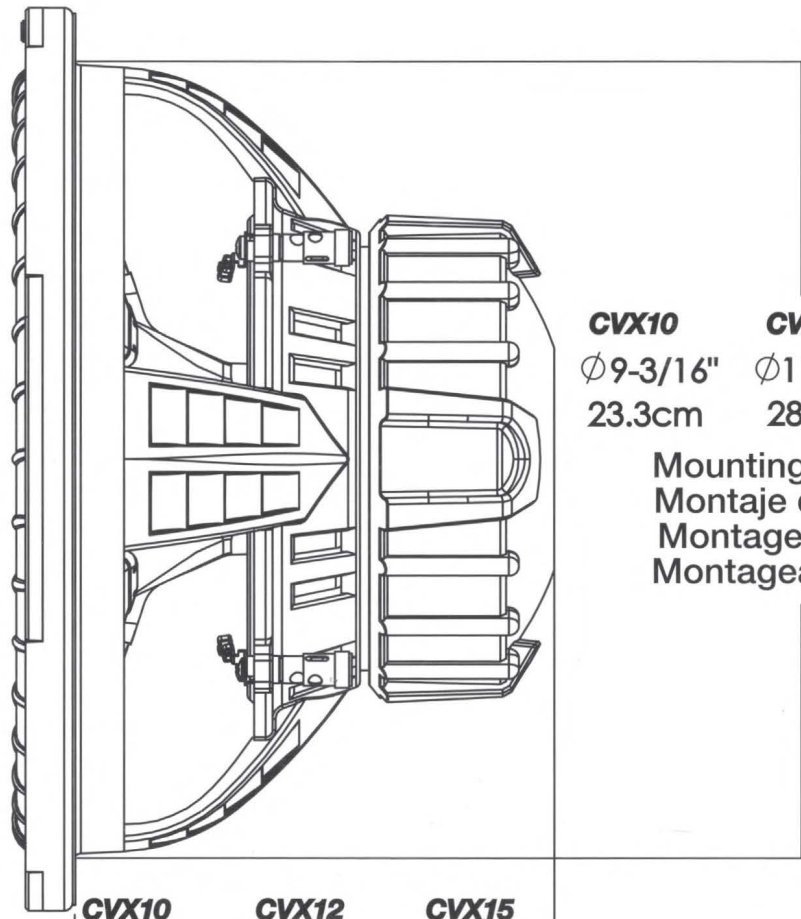

<b>CVX10</b>	<b>CVX12</b>	<b>CVX15</b>
$\phi 9-3/16"$	$\phi 11-1/16"$	$\phi 13-13/16"$
23.3cm	28.1cm	35.0cm

**Mounting Diameter**  
**Montaje de recorte**  
**Montage Découpe**  
**Montageausschnitt**

<b>CVX10</b>	<b>CVX12</b>	<b>CVX15</b>
$5-15/16"$	$6-11/16"$	$8-1/2"$
15.1cm	16.9cm	21.5cm

**Mounting Depth**  
**Montaje Profundidad**  
**Profondeur de montage**  
**Einbautiefe**

Coil 2 - Positive (Red)  
 Bobina de Voz 2 - Positiva (Roja)  
 Bobine vocale 2 - Positive (Rouge)  
 Schwingspule 2 - Positive (Rote)

Coil 2 - Negative (Black)  
 Bobina de Voz 2 - Negativa (Negra)  
 Bobine vocale 2 - Négative (Noir)  
 Schwingspule 2 - Negative (Schwarz)

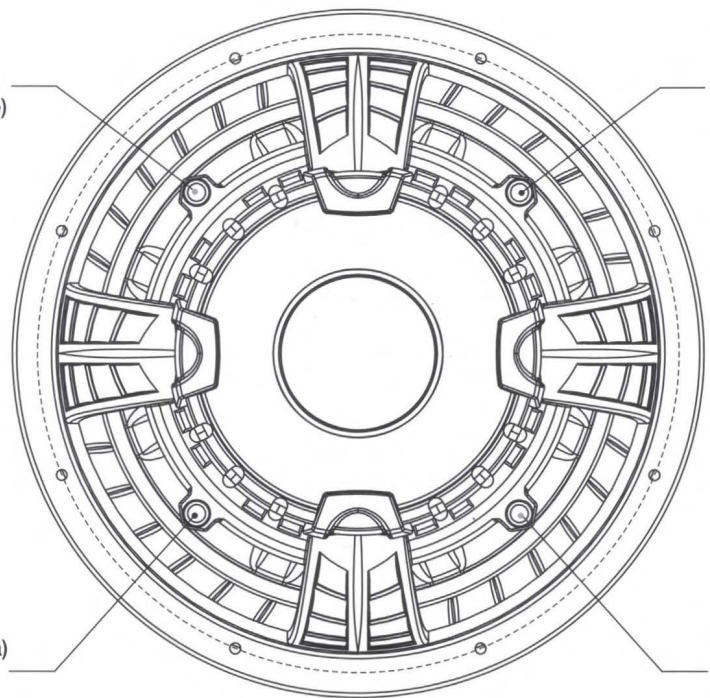

Coil 1 - Negative (Black)  
 Bobina de Voz 1 - Negativa (Negra)  
 Bobine vocale 1 - Négative (Noir)  
 Schwingspule 1 - Negative (Schwarz)

Coil 1 - Positive (Red)  
 Bobina de Voz 1 - Positiva (Roja)  
 Bobine vocale 1 - Positive (Rouge)  
 Schwingspule 1 - Positive (Rote)