



# VIV

## SIXFIVE SERIES



**VIV60C | COMPONENT SPEAKER SET**

MEMPHIS AUDIO | MEMPHIS, TN USA | EST. 1965

**Features**

- 2 Layer composite Fiber cone
- Aluminum housed Silk Dome Tweeter
- Bi-amp versatile Crossover
- Cast Aluminum Six Five Basket
- 2Ω Design

**Woofers Technical Information**

Nominal Diameter	6.49 in // 165mm
Driver mounting depth	2.91 in // 74mm
Speaker weight	1520 g
Basket Material	ALUMINUM
Magnet height	.71in // 18 mm
Magnet diameter	3.93 x 1.77 x .71in // 100 x 45 x 18 mm
Magnet weight	20 OZ

**Woofers Moving Object Technical Information**

Voice Coil Diameter	1.18 in // 30 mm
Voice Coil Former Material	KSV
Voice Coil Nominal Impedance	2 OHM
Cone Material	FIBER GLASS +FOAM COMPOSITE
Dust Cap Material	ALUMINUM BULLET
Surround Material	RUBBER

**Tweeters Technical Information**

Dome Material	SILK
Dome Diameter	1.45 in // 37 mm
Voice Coil Diameter	.98 in // 25 mm

**Crossover Technical Information**

Crossover Type	2WAY
Tweeter Crossover slope	+/- 3dB
Tweeter Crossover frequency	4800 Hz
Woofers Crossover Slope (Low Pass)	6DB/12 dB
Woofers Crossover Slope (High Pass)	12 dB
Woofers Crossover frequency (HP)	4800 Hz

### Installation

Prior to setting up your audio system, disconnecting the negative battery terminal from your vehicle is advised. Prior to cutting or drilling screws, please take time to check clearances on both sides of the mounting surface. Be mindful of any potential obstacles such as window tracks and motors. Some vehicles are not symmetrical making it imperative to double check both sides of the vehicle.

### Crossover Network

Always mount your crossovers in a location free from moisture and away from moving parts. Crossovers should not be mounted inside door compartments if possible as doors are not always watertight and moisture may damage your crossover. Your Crossover must be connected as shown in this manual, failure to follow these connections may void your warranty and potentially damage your system and vehicle. Failure to properly install the crossovers may void your warranty. If you are uncomfortable with any of the installation steps it is advised that you contact your local Memphis Audio dealer.

### Speaker Placement

A properly installed component system will yield the best sound for a vehicle. Failure to properly place your component system can severely hinder your systems performance. A Memphis Audio dealer should be consulted to properly position your vehicles components for the best possible performance. Ideally the tweeter and woofer should be installed free from obstacles impeding sound from freely traveling throughout the vehicle. Woofers should be mounted lower in the vehicle while tweeters typically perform better in a more elevated position. Prior to cutting any holes or making any alterations to your vehicle, test fit the woofers into the factory mounting locations to confirm that they clear any obstacles such as window tracks, wire harnesses etc. If you are mounting the woofers into a non factory location check both sides of the vehicle for obstacles prior to cutting or altering your vehicle in any way. A speaker cut out template is provided in the box along with this product, again do not rely solely on the template, be certain to test fit and measure both sides of the vehicle prior to altering your vehicle. To test the tweeters prior to committing to a mounting location you can simply install the rest of your system and position your tweeters in various locations using double sided tape until you find an ideal location.

### Tweeter Installation

Tweeters should be positioned high, preferably near ear level. Optimum performance will be obtained when tweeters are angled toward the listener.

The least conspicuous tweeter mounting option is a flush mount. The recessed design provides superior protection for the tweeter and it blends with the interior of your vehicle.

To mount the tweeter cut a hole in the desired panel. Slide the tweeter into place. Use the included screw and backer bracket to tighten the tweeter into place. The final installation should look like the above image.

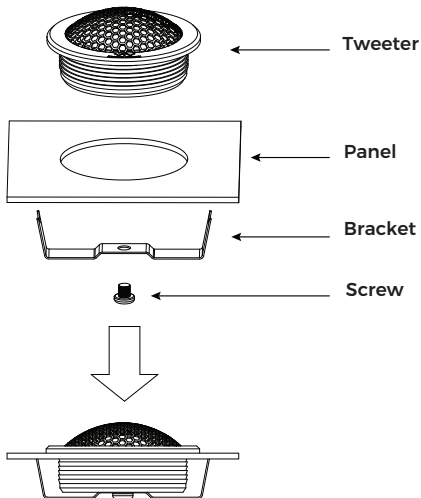

#### SIXFIVE SERIES WARRANTY

Memphis Car Audio offers a limited warranty on Memphis Car Audio products on the following terms:

##### Length of Warranty

SixFive Series Component Speakers - 2 Year  
Ask your installing dealer about warranty extensions that may be available.

##### What Is Covered

This warranty applies only to Memphis Car Audio products sold to consumers by Authorized Memphis Car Audio Dealers in the United States of America or its possessions.

##### Who Is Covered

This warranty covers only the original purchaser of Memphis Car Audio product purchased from an Authorized Memphis Car Audio Dealer in the United States. In order to receive service, the purchaser must provide Memphis Car Audio with a copy of the receipt stating the consumer name, dealer name, product purchased, and date of purchase. Products found to be defective during the warranty period will be repaired or replaced (with a product deemed to be equivalent) at Memphis Car Audio's discretion.

##### What Is Not Covered

1. Damage caused by accident, abuse, improper operation or installation, water, theft, shipping.
2. Any cost or expense related to the removal or re installation of product.
3. Service performed by anyone other than Memphis Car Audio.
4. Any product which has had the serial number defaced, altered, or removed.
5. Subsequent damage to other components.
6. Any product purchased outside the US.
7. Any product not purchased from an authorized Memphis Car Audio Dealer.

##### Limit on Implied Warranties

Any implied warranties including warranties of fitness for use and merchantability are limited in duration to the period of the express warranty set forth above. Some states do not allow limitations on the length of an implied warranty, so this limitation may not apply. No person is authorized to assume for Memphis Car Audio any other liability in connection with the sale of the product.

##### EU Warranty

This product meets the current EU warranty requirements. See your Authorized dealer for details.

##### How To Obtain Service

Contact the Authorized Memphis Car Audio Dealer you purchased this product from.  
If you need further assistance, call 1-800-489-2300 for Memphis Car Audio's Customer Service.

**YOU MUST OBTAIN A RETURN AUTHORIZATION (RA#) TO RETURN ANY PRODUCT TO MEMPHIS CAR AUDIO'S WARRANTY FACILITY. NO PRODUCT WILL BE ACCEPTED WITHOUT THIS RETURN AUTHORIZATION!**

You are responsible for shipment of product to Memphis Car Audio. Repaired and replaced product will be returned freight prepaid.

FOR MORE INFORMATION, PLEASE VISIT: [WWW.MEMPHISCARAUDIO.COM](http://WWW.MEMPHISCARAUDIO.COM)

**WIRING COMPONENTS - NON BI-AMPED SET UP**

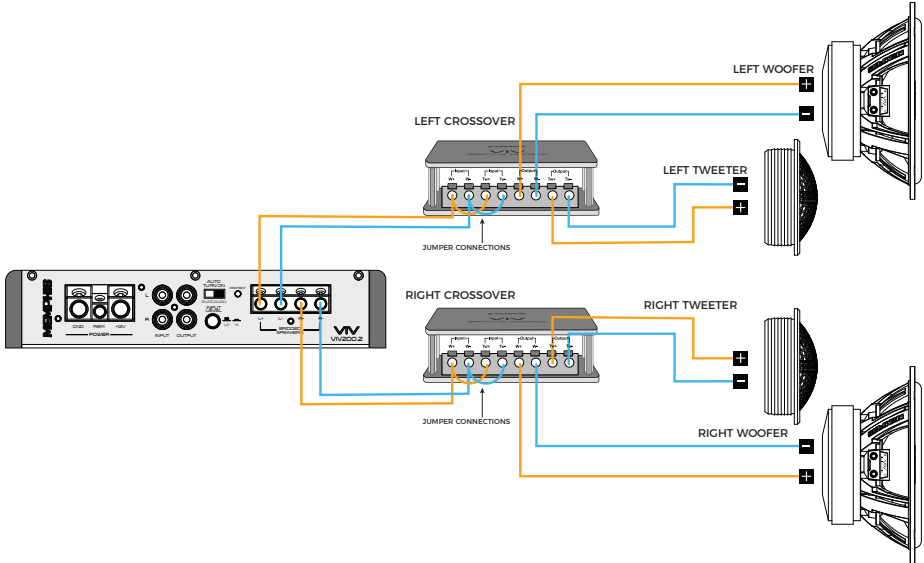

**WIRING COMPONENTS - BI-AMPED SET UP**

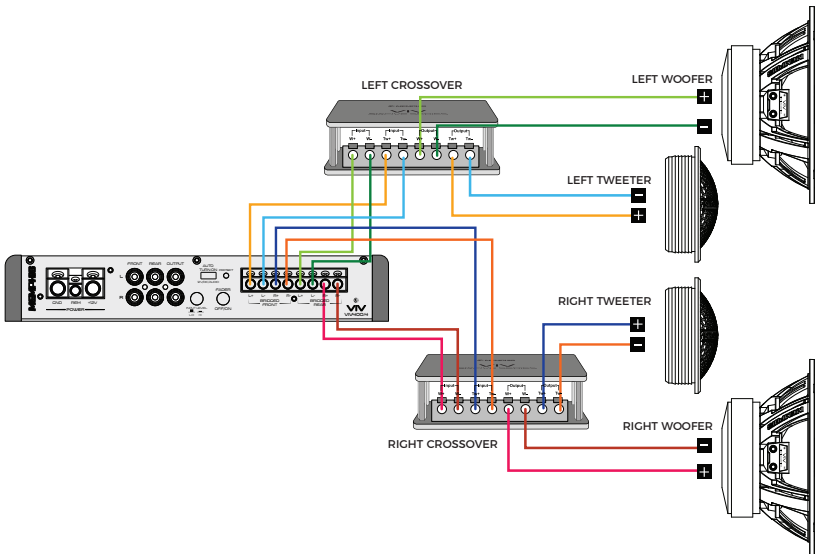

Crossover Adjustments

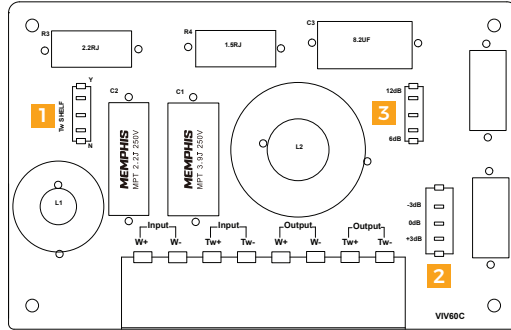

VIV60C Crossovers uses switches to adjust a variety of features allowing the user to dial in the perfect sound for their audio system.

**1** Tweeter Shelf: Boosts 9K and up

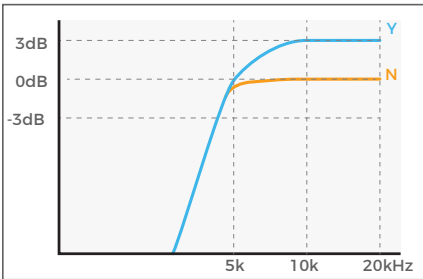

**2** Tweeter Adj. +/-3 dB Tweeter Adjustment

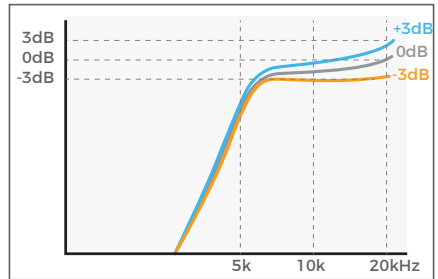

**3** Woofer Crossover Slope 6dB/12dB

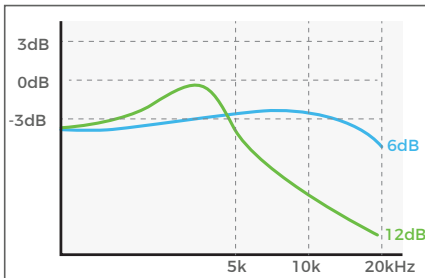

# VIV

## SIXFIVE SERIES

a half century in the making...



CONTACT INFO  
122 CAYOSO AVE. MEMPHIS, TN 38103

SHOW US YOUR INSTALL & FOLLOW US TODAY!



[WWW.MEMPHISCARAUDIO.COM](http://WWW.MEMPHISCARAUDIO.COM)



@MEMPHISCARAUDIO



@MEMPHISCARAUDIOUSA