

Pioneer

Owner's Manual
Mode d'emploi
Manual de instrucciones

MARINE MONO AMPLIFIER
AMPLIFICATEUR MONOBLOC MARIN
AMPLIFICATEUR MONOAURAL MARINO

GM-ME300X1C

English
Français
Español

Before you start

Thank you for purchasing this PIONEER product

To ensure proper use, please read through this manual before using this product. It is especially important that you read and observe **WARNINGS** and **CAUTIONS** in this manual. *Please keep the manual in a safe and accessible place for future reference.*

Information to User

Alteration or modifications carried out without appropriate authorization may invalidate the user's right to operate the equipment.

Note

This equipment has been tested and found to comply with the limits for a Class B digital device, pursuant to Part 15 of the FCC Rules. These limits are designed to provide reasonable protection against harmful interference in a residential installation. This equipment generates, uses and can radiate radio frequency energy and, if not installed and used in accordance with the instructions, may cause harmful interference to radio communications. However, there is no guarantee that interference will not occur in a particular installation. If this equipment does cause harmful interference to radio or television reception, which can be determined by turning the equipment off and on, the user is encouraged to try to correct the interference by one or more of the following measures:

- Reorient or relocate the receiving antenna.
- Increase the separation between the equipment and receiver.
- Connect the equipment into an outlet on a circuit different from that to which the receiver is connected.
- Consult the dealer or an experienced radio/TV technician for help.

FEDERAL COMMUNICATIONS
COMMISSION SUPPLIER'S DECLARATION
OF CONFORMITY

Product Name: Marine Mono Amplifier
Model Number: GM-ME300X1C
Responsible Party Name: PIONEER
ELECTRONICS (USA) INC.
SERVICE SUPPORT DIVISION
Address: 2050 W. 190TH STREET, SUITE 100,
TORRANCE, CA 90504, U.S.A.
Phone: 1-800-421-1404
URL: <https://www.pioneerelectronics.com>

After-sales service for Pioneer products

Please contact the authorized Pioneer dealer from which you purchased this unit or an authorized Pioneer service company for after-sales service or questions you may have about the product. You may contact Pioneer directly as follows:

Do not ship your unit in for repair without contacting Pioneer first. Units sent without a return authorization number will be refused.

USA & CANADA

Pioneer Electronics (USA) Inc.
CUSTOMER SUPPORT DIVISION
P.O. Box 1760
Long Beach, CA 90801-1760 U.S.A.
800-421-1404

For warranty information, please see the Limited Warranty sheet included with this unit.

Visit our website

U.S.:

<https://www.pioneerelectronics.com>

Canada:

<https://www.pioneerelectronics.ca>

- Learn about product updates (such as firmware updates) for your product.
- Register your product.
- Access owner's manuals, spare parts information, service information, and much more.

The Safety of Your Ears is in Your Hands

Get the most out of your equipment by playing it at a safe level—a level that lets the sound come through clearly without annoying blaring or distortion and, most importantly, without affecting your sensitive hearing. Sound can be deceiving. Over time, your hearing “comfort level” adapts to higher volumes of sound, so what sounds “normal” can actually be loud and harmful to your hearing. Guard against this by setting your equipment at a safe level BEFORE your hearing adapts.

ESTABLISH A SAFE LEVEL:

- Set your volume control at a low setting.
- Slowly increase the sound until you can hear it comfortably and clearly, without distortion.
- Once you have established a comfortable sound level, set the dial and leave it there.

BE SURE TO OBSERVE THE FOLLOWING GUIDELINES:

- Do not turn up the volume so high that you can't hear what's around you.
- Use caution or temporarily discontinue use in potentially hazardous situations.
- Do not use headphones while operating a boat; the use of headphones may create a traffic hazard and is illegal in many areas.

Before connecting/installing the amplifier



WARNING

- To prevent fire hazard, the heatsink should never be covered (such as by paper, material, etc.).
 - This unit is for boats with a 12 V battery and negative grounding. Before installing, check the battery voltage.
 - When installing this unit, make sure to connect the ground wire first. Ensure that the ground wire is properly connected to the negative ground circuit of the boat. Use adequate gauge, marine grade electrical wire that has been properly terminated for marine use to make a direct connection to the negative bus bar or negative ground distribution system.
- Do not attempt to ground the amplifier using the mounting screws.
 - Use fused marine grade battery wire (sold separately) of adequate gauge that has been properly terminated for marine use to make a direct connection to the positive bus bar or positive distribution system.
 - **If the screw for the ground wire loosens or falls out, it could result in fire, smoke or malfunction.**
 - Always use a fuse of the rating prescribed. The use of an improper fuse could result in overheating and smoke, damage to the product, and injury, including burns.
 - Check all electrical and signal connections (power, ground, amplifier, speaker, etc.) if amplifier fuse or battery wire fuse blows. Resolve any loose or short circuited connections, then replace the blown fuse with an identical value equivalent.
 - Always install the amplifier on an even surface. Do not install the amplifier on a surface that is uneven or has a protrusion. Doing so could result in malfunction.
 - When installing the amplifier, do not allow parts such as extra screws to get caught between the amplifier and the boat. Doing so could cause malfunction.
 - In the event of any abnormality, the power supply to the amplifier may cut off to prevent equipment malfunction. If this occurs, switch the system power off and check all electrical and signal connections (power, ground, amplifier, speaker, etc.) for loose or short circuited connections. If you are unable to determine the cause, please contact your dealer.
 - Always disconnect the negative \ominus terminal of the battery before making any electrical or signal connections to avoid the risk of electric shock or short circuit during installation.
 - Do not attempt to disassemble or modify this unit. Doing so may result in fire, electric shock or other malfunction. Damage or defects resulting from alterations or modifications not authorized in writing by Pioneer are excluded from limited warranty coverage.
 - Do not install the amplifier in a location exposed to direct sunlight or excessive heat, humidity or dust.

- While this amplifier is designed to be water-resistant, it should never be submerged under water or subjected to high-pressure water spray.
- Install the amplifier in a dry and well-ventilated environment, where other equipment will not interfere with it.
- When drilling holes in the chassis for installation, take precautions so as not to contact, damage or obstruct pipes, fuel lines, tanks or electrical wiring. Failure to take such precautions may result in fire.
- To ensure proper heat dissipation of the amplifier, ensure the following during installation:
 - Allow adequate space above the amplifier for proper ventilation.
 - Do not mount the amplifier in the engine compartment or in any areas of extreme heat.
 - Do not cover the amplifier.
- **Ask your dealer or installation professional to install/uninstall this product. Incorrect installation can create dangerous hazards or interfere with boat operation.**
- Keep small items such as bolts, screws and tools out of the reach of children. Swallowing can cause serious injury. If swallowed, consult a doctor immediately.

CAUTION

- Always keep the volume low enough to hear outside sounds.
- Extended use of the amplifier while the engine is at rest or idling may exhaust the battery.
- The graphical symbol  placed on the product means this is an electronic product requiring direct current electrical power.
- One or more subwoofers may be connected to this amplifier, but must meet one of the following configurations:
 - Combined or singular nominal input power handling of 300W or greater if the combined or singular nominal impedance is equal to or greater than 2Ω.

WARNING: If the nominal input and impedance are not within the above ranges, the subwoofer(s) may catch

fire, emit smoke or become damaged. DO NOT use the amplifier with subwoofer configurations with a combined or singular nominal impedance less than 2Ω.

About the protection function

This product has a protection function. If this product detects something abnormal, the Power/Protect indicator will turn red and the operation of amplifier will be stopped.

Possible causes include:

- When the temperature inside the product becomes high
- When speaker output detects an abnormality
- When the supply voltage is out of specification



Important (Serial number)

The serial number is located on the bottom of this unit. Be sure to record this number on the enclosed warranty card before installation.

Setting the unit

What's what

Top side

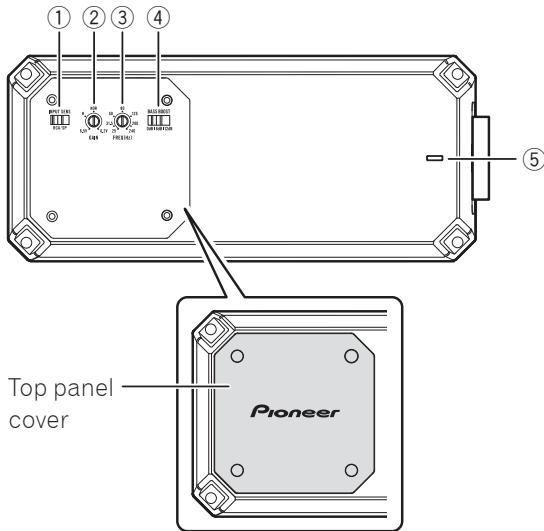

- Use the supplied wrench to remove the four screws and detach the top panel cover. Be sure not to lose the removed screws.

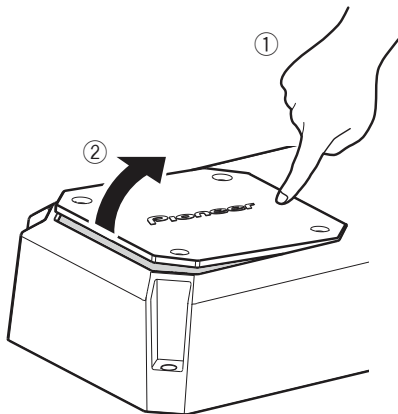

- Use a flathead screwdriver to adjust the switch if needed.

Right side

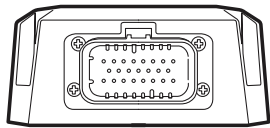

- ① **INPUT SENS switch**
Select **RCA** for RCA level input signals or **SP** for Speaker level input signals.
- ② **GAIN volume**
If the output remains low even when the headunit volume is turned up, turn the volume to a lower level (clockwise). If distortion occurs when the headunit volume is turned up, turn these volumes to a higher

level (counterclockwise).

- For use with an RCA equipped stereo (standard output of 500 mV), set to the **NOR** (normal) position. For use with an RCA equipped Pioneer headunit with maximum output of 4 V or more, adjust level to match that of the stereo output.
 - For use with an RCA equipped headunit with output of 4 V, set to the **H** (High) position.
 - If you hear too much noise when using the speaker input terminals, turn the gain control to higher level.
- ③ **FREQ (Hz) (cutoff frequency)**
You can select a cutoff frequency from 25 Hz to 240 Hz. For precise frequency information, refer to *Precise Frequency Selection Chart*.
 - ④ **BASS BOOST switch**
You can select a bass boost level of 0 dB, 6 dB, or 12 dB.
 - ⑤ **Power/Protect indicator**
The power indicator lights blue to indicate power ON.
 - The power indicator lights red to indicate protection mode has been engaged.

Setting gain properly

- A protective function is included to avoid malfunction of the unit and/or speakers due to excessive output, improper use or improper connection.
- When outputting high volume sound etc., this function may cut off the output for a few seconds as a normal function. Output will be restored when the volume of the headunit is turned down.
- A cut in sound output may indicate improper setting of the gain volume. To ensure continuous sound output with the headunit at a high volume, set the amplifier gain volume to a level appropriate for the preout maximum output level of the headunit, so that volume can remain unchanged and to avoid distortion caused by signal waveform clipping at the amplifier input.
- Even with correct volume and gain settings, the unit sound may cut out periodically. In such cases, please contact an authorized Pioneer Service Company.

Gain volume of this unit

0.5 V (Maximum preout level=2 V)

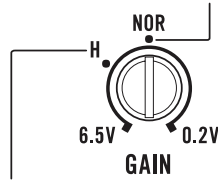

Maximum preout level=4V

Above illustration shows **NOR** (normal) gain setting.

Relationship between amplifier gain and headunit output power

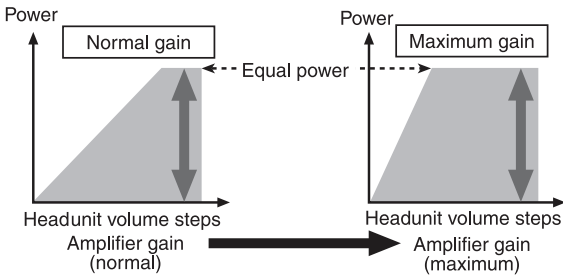

If amplifier gain is raised improperly, this will simply increase distortion, with little increase in power.

Signal waveform when outputting at high volume using amplifier gain volume

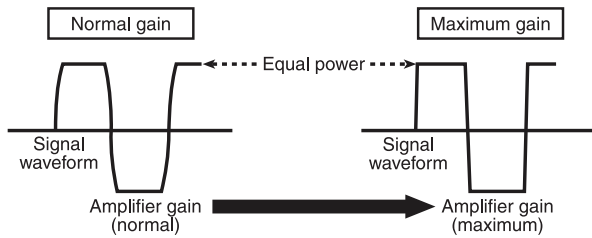

If the signal waveform is distorted due to high output, even if the amplifier gain is raised, the output power will change only slightly.

Precise Frequency Selection Chart

The numbers in the illustration correspond to the Step Number.

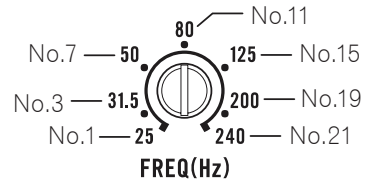

Step Number	Frequency (Hz)
1	25
2	28
3	31.5
4	36
5	40
6	45
7	50
8	56
9	63
10	71.5
11	80
12	90
13	100
14	113
15	125
16	143
17	160
18	180
19	200
20	225
21	240

Connecting the units

Connection diagram

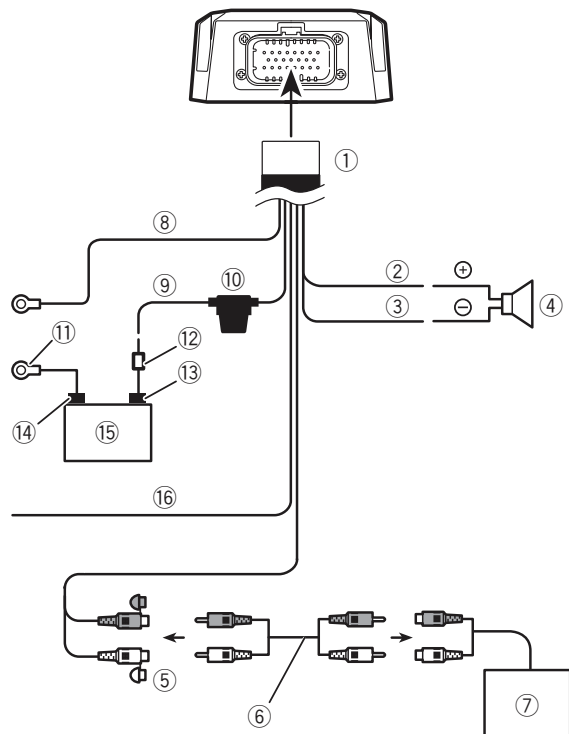

- ① To power cable input
- ② White: ⊕
- ③ White/black: ⊖
- ④ Speaker
- ⑤ RCA input
- ⑥ Connecting wire with RCA pin plugs (sold separately)
- ⑦ Headunit with RCA output jacks (sold separately)
- ⑧ Black (chassis ground)
Connect to a clean, paint-free metal location.
- ⑨ Red
- ⑩ Fuse (30 A)
- ⑪ Ground wire, Terminal (sold separately)
The ground wires must be the same size as the battery wire.
- ⑫ Battery wire with Fuse [more than 30A] (sold separately)
The maximum length of the wire between the fuse and the positive ⊕ terminal of the battery is 30 cm (12 in.).
- ⑬ Positive ⊕ terminal
- ⑭ Negative ⊖ terminal
- ⑮ Battery (sold separately)
- ⑯ System remote control wire

Before connecting the amplifier

⚠ WARNING

- Secure the wiring with cable clamps or adhesive tape. To protect the wiring, wrap sections in contact with metal parts in adhesive tape.
- Never cut the insulation of the power supply to feed power to other equipment. Current capacity of the wire is limited.

⚠ CAUTION

- If the system remote control wire of the amplifier is connected to the power terminal via the ignition switch (12 V DC), the amplifier will remain on with the ignition whether the headunit is on or off, which may exhaust battery if the engine is at rest or idling.
- Install and route the separately sold marine grade battery wire, marine grade ground wire, speaker wires and the amplifier as far away as possible from the radio antenna, antenna cable, tuner and any communications equipment and wiring.

The point of connector attachment/detachment

- Push in the connector until a clicking sound is heard, confirming a secure connection.
- How to remove the connector:
 - (1) Insert the supplied tool into the lock part of the connector.
 - (2) Gently raise the release locking tab to separate the connector.

Note: Attempting to remove the connector by force or pulling from the wire harness can cause damage. To avoid injury, use a work glove to help with gripping the tool.

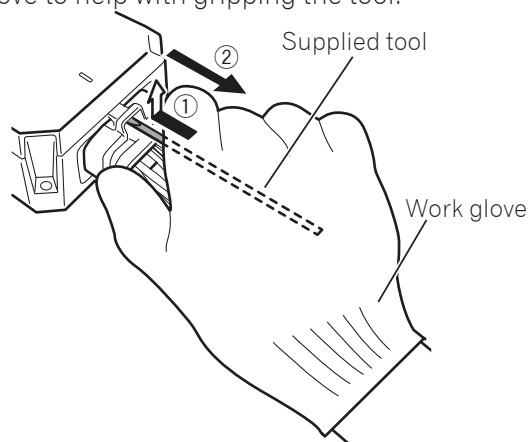

- Continue to page 7/9 -

If you lose the supplied tool, use a flat screwdriver with a tip width of 3 mm or less as a substitute.



Connections when using the speaker input wire

Connect the headunit speaker output wires to the amplifier using the supplied speaker input wire with RCA pin cord.

- Make sure to switch the **INPUT SENS** switch to **SP**.

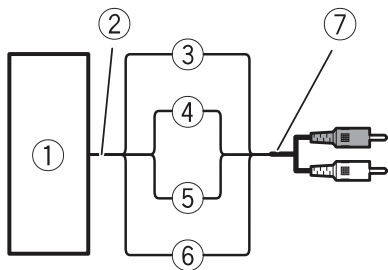

- ① Headunit
- ② Speaker output
- ③ Red: Right ⊕
- ④ Black: Right ⊖
- ⑤ Black: Left ⊖
- ⑥ White: Left ⊕
- ⑦ Speaker input wire with RCA pin cord to the RCA input jack of this unit

Note

- If speaker input wires from a headunit are connected to this amplifier, the amplifier will automatically turn on when the headunit is turned on. When the headunit is turned off, the amplifier turns off automatically. This function may not work with some headunits. In such cases, make sure that the L channel is connected correctly. If the function still does not work, please use a system remote control wire (sold separately). If multiple amplifiers are to be connected together synchronously, connect the headunit and all amplifiers via the system remote control wire.

Installation

Before installing the amplifier

⚠ WARNING

- To ensure proper installation, use the supplied parts in the manner specified. If any parts other than those supplied are used, they may damage internal parts of the amplifier or become loose, causing the amplifier to shut down.
- Do not install:
 - On surfaces that could become loose if the boat stops suddenly (chassis recommended).
 - In places where it may interfere with the boat's operation.
- Install tapping screws in such a way that the screw tip does not touch any wire. This is important to prevent wires from being cut by vibration of the boat, which can result in fire.
- Make sure that wires do not get caught in the sliding mechanism or touch the legs of a person in the boat as short-circuit may result.

⚠ CAUTION

- Place all cables away from hot places, such as near the heater outlet.
- The optimal installation location differs depending on the boat model. Secure the amplifier at a sufficiently rigid location.
- Check all connections and systems before final installation.

Example of installation on the chassis

1 Place the amplifier in the desired installation location.

Insert the supplied tapping screws (4 mm × 25 mm) into the screw holes and push on the screws with a screwdriver so they make an imprint where the installation holes are to be located.

2 Drill 2.5 mm (1/8 in.) diameter holes in the mounting surface.

3 Install the amplifier with the use of supplied tapping screws (4 mm × 25 mm).

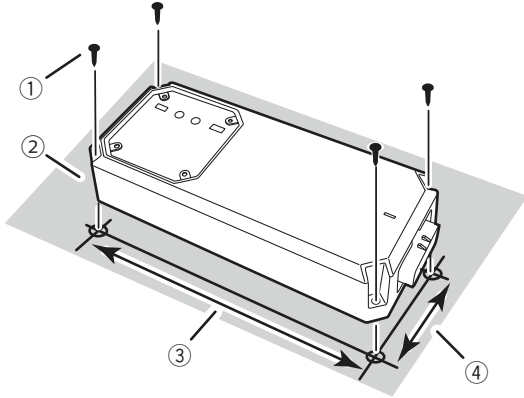

- ① Tapping-screws (4 mm × 25 mm) (5/32 in. × 1 in.)
- ② Installation surface
- ③ Hole-to-hole distance: 224.4 mm (8-27/32 in.)
- ④ Hole-to-hole distance: 86.4 mm (3-13/32 in.)

4 Attach the top panel cover.

Use the removed screws to attach the top panel cover (fastening torque 0.4 to 0.7 N·m).

Attach the top panel cover in the same orientation as the main unit installation orientation.

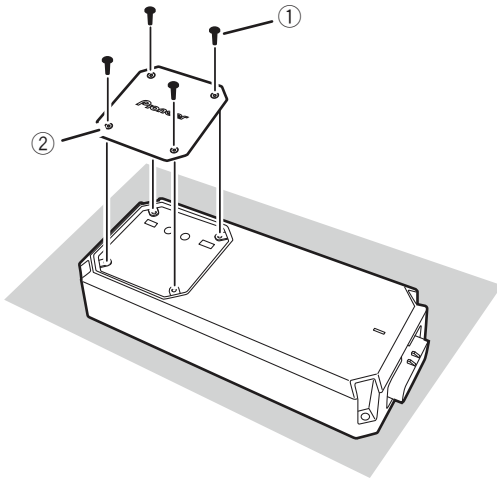

- ① Screws
- ② Top panel cover

Additional information

Specifications

Power source	14.4 V DC (10.8 V to 15.1 V allowable)
Grounding system	Negative type
Current consumption.....	25 A (at continuous power, 4 Ω)
Average current consumption	5.6 A (4 Ω for one channel) 6.3 A (2 Ω for one channel)
Fuse	30 A
Dimensions (W × H × D) ..	243 mm × 46.8 mm × 105 mm (9-5/8 in. × 1-7/8 in. × 4-1/8 in.)
Weight	1.3 kg (2.9 lbs) (Leads for wiring not included)
Continuous power output..	300 W × 1 (at 14.4 V, 4 Ω, 20 Hz to 240 Hz, ≤ 1 % THD) 300 W × 1 (at 14.4 V, 2 Ω, 100 Hz, ≤ 1 % THD)
Load impedance	4 Ω (2 Ω to 8 Ω allowable)
Frequency response.....	10 Hz to 240 Hz (+0 dB, -3 dB)
Signal-to-noise ratio.....	100 dB (IHF-A network)
Distortion	0.5 % (10 W)
Low pass filter:	
Cutoff frequency.....	20 Hz to 240 Hz
Cutoff slope.....	-12 dB/oct
Gain control:	
RCA.....	0.2 V to 6.5 V
Speaker.....	0.8 V to 16 V
Maximum input level / impedance:	
RCA.....	6.5 V / 25 kΩ
Speaker.....	16 V / 12 kΩ
Waterproof	JIS/IEC protection class 7 (IPX7) equivalent (self-certified)
Dustproof	JIS/IEC protection class 6 (IP6X) equivalent (self-certified)



CTA2006 Specifications



Power output.....	300 W RMS × 1 Channel (at 14.4 V, 4 Ω , 20 Hz to 240 Hz and \leq 1 % THD+N)
S/N ratio	75 dBA (reference: 1 W into 4 Ω)

Accessories

Power cable × 1
Speaker line input RCA cable × 1
Hexagonal wrench × 1
Mounting screw (4 × 25 mm) × 4
Supplied tool × 1

Notes

- Specifications and design are subject to modification without notice.
- The average current consumption is nearly the maximum current consumption by this unit when an audio signal is input. Use this value when working out total current consumption by multiple power amplifiers.

*Register your product at
Enregistrez votre produit au
Registre su producto en*

<https://www.pioneerelectronics.com>

*in Canada
au Canada
en Canadá*

<https://www.pioneerelectronics.ca>

PIONEER CORPORATION

28-8, Honkomagome 2-chome, Bunkyo-ku,
Tokyo 113-0021, JAPAN

PIONEER ELECTRONICS (USA) INC.

P.O. Box 1540, Long Beach, California 90801-1540, U.S.A.
TEL: (800) 421-1404

© 2020 PIONEER CORPORATION.



**PIONEER ELECTRONICS (USA) INC.
LIMITED WARRANTY**

WARRANTY VALID ONLY IN COUNTRY OF PRODUCT PURCHASE

WARRANTY

Pioneer Electronics (USA) Inc. (Pioneer) warrants that Pioneer® Car/Marine Electronics, Speaker, and Accessory Products distributed by Pioneer in the U.S.A. and Canada that fail to function properly under normal use due to a manufacturing defect when installed and operated according to the owner's manual enclosed with the unit will be repaired or replaced with a unit of comparable value, at Pioneer's option, without charge to you for parts or actual repair work. Replacement units and/or parts supplied under this warranty may be new or rebuilt at Pioneer's option.

This Limited Warranty applies to the original or any subsequent owner of this Pioneer product during the warranty period provided the product was purchased from an authorized Pioneer dealer in the U.S.A. or Canada. **You will be required to provide a sales receipt or other valid proof of purchase showing the date of original purchase. In the event service is required, the product must be delivered within the warranty period, transportation prepaid, only from within the country of purchase as explained in this document. You will be responsible for removal and installation of the product.** Pioneer will pay to return the repaired or replacement product to you within the country of purchase.

PRODUCT WARRANTY PERIOD (Runs from the date of first retail sale)	Parts	Labor
Car/Marine Electronics, Speakers, and Accessories (excluding Blind Spot Detection System).....	1 Year	1 Year
Blind Spot Detection System	3 Years	3 Years

WHAT IS NOT COVERED

This Limited Warranty applies to Pioneer products that are purchased from an authorized Pioneer dealer. **IF THIS PRODUCT WAS PURCHASED FROM ANY OTHER SOURCE, THERE ARE NO WARRANTIES, EXPRESS OR IMPLIED, INCLUDING THE IMPLIED WARRANTY OF MERCHANTABILITY AND THE IMPLIED WARRANTY OF FITNESS FOR A PARTICULAR PURPOSE AND THIS PRODUCT IS SOLD STRICTLY "AS IS" AND "WITH ALL FAULTS."** PIONEER SHALL NOT BE LIABLE FOR ANY CONSEQUENTIAL AND/OR INCIDENTAL DAMAGES. Some states and provinces do not allow the exclusion or limitation of incidental or consequential damages, so the above limitation or exclusion may not apply to you.

Pioneer does not warrant any product listed above when it is used in a trade or business or in any industrial or commercial application. This warranty does not apply if the product has been subjected to power in excess of its published power rating. This warranty does not cover cosmetic scratches or any other appearance item; damage or defects resulting from alterations or modifications not authorized in writing by Pioneer; accident, collisions, misuse or abuse; the use of unauthorized parts or labor; improper installation or maintenance; lightning or power surges; subsequent damage from leaking; damage from inoperative batteries; or the use of batteries not conforming to those specified in the owner's manual. This warranty does not cover the cost of parts or labor that would otherwise be provided without charge under this warranty obtained from any source other than Pioneer. Altered, defaced, or removed serial numbers void this warranty.

NO OTHER WARRANTIES

TO THE FULLEST EXTENT PERMITTED BYLAW, PIONEER MAKES NO REPRESENTATIONS OR WARRANTIES OR ACCEPTS ANY CONDITIONS WITH RESPECT TO THIS PRODUCT EXCEPT AS STATED IN THIS DOCUMENT. PIONEER LIMITS ITS OBLIGATIONS UNDER ANY IMPLIED WARRANTIES AND CONDITIONS INCLUDING, BUT NOT LIMITED TO, WARRANTIES AND CONDITIONS, WHETHER EXPRESS OR IMPLIED, OF MERCHANTABILITY AND FITNESS FOR A PARTICULAR PURPOSE, TO A PERIOD NOT TO EXCEED THE WARRANTY PERIOD. NO WARRANTIES OR CONDITIONS SHALL APPLY AFTER THE WARRANTY PERIOD. Some states and provinces do not allow limitations on how long an implied warranty lasts, so the above limitations or exclusions may not apply to you.

This warranty gives you specific legal rights, and you may also have other rights which vary from state to state or province to province. To the extent any provision of this limited warranty is deemed invalid or unenforceable under applicable law, such determination will have no effect on the remaining provisions, which will continue in full force and effect.

TO OBTAIN SERVICE

In the U.S.A. or Canada, to receive warranty service, you need to present your sales receipt showing place and date of original owner's transaction. **Please contact one of the following to obtain service:**

Your Authorized Pioneer Dealer - Your Pioneer Dealer may repair or replace your unit or refer you to an Authorized Pioneer Service Company. Your sales receipt should list the contact information (phone number, fax, email, etc.) for your Dealer.

Pioneer Customer Support - Can advise the optimal service option for your model and geographic location.

Please call us at **1-800-421-1404** or visit **www.pioneerelectronics.com** (for USA) or **http://www.pioneerelectronics.ca** (for Canada), click on **"Support,"** then select **"Contact Us."**

Your Authorized Pioneer Service Company - Can perform repairs for most Car/Marine Electronics, Speaker and Accessory products and advise other options as applicable. Please visit Pioneer's website, click on **"Support,"** and select **"Find a Service Center."**

Shipping Your Unit for Service – YOU MUST FIRST CONTACT PIONEER TO GET RETURN AUTHORIZATION. PLEASE DO NOT SEND IN YOUR PRODUCT WITHOUT CONTACTING CUSTOMER SUPPORT. If you have a return authorization number, please package the product carefully and send it transportation prepaid by a traceable, insured method to an Authorized Pioneer Service Company or Pioneer. Use adequate padding material to prevent damage in transit. Include your name, address and a telephone number where you can be reached during business hours.

For questions about your product, please contact Pioneer Customer Support as described above or write to us at:

**Customer Support, Pioneer Electronics (USA) Inc.
P.O. Box 1720
Long Beach, California 90801 U.S.A.**

DISPUTE RESOLUTION

Following our response to any initial request to Customer Support, should a dispute arise between you and Pioneer, Pioneer makes available its Complaint Resolution Program to resolve the dispute. The Complaint Resolution Program is available to you without charge. In the U.S.A., you are required to use the Complaint Resolution Program before you exercise any rights under, or seek any remedies, created by the Magnuson-Moss Warranty Act but may be entitled to file suit under state law without using the Complaint Resolution Program. To use the Complaint Resolution Program, call 1-800-421-1404 and explain to the customer service representative the problem you are experiencing, steps you have taken to have the product repaired during the warranty period, and the name of the authorized Pioneer Dealer from which the Pioneer product was purchased. After the complaint has been explained to the representative, a resolution number will be issued. Within forty (40) days of receiving your complaint, Pioneer will investigate the dispute and will either: (1) respond to your complaint in writing informing you what action Pioneer will take, and in what time period, to resolve the dispute; or (2) respond to your complaint in writing informing you why Pioneer will not take any action.

RECORD THE PLACE AND DATE OF PURCHASE. KEEP THIS INFORMATION AND YOUR SALES RECEIPT IN A SAFE PLACE

Model No. _____ Serial No. _____ Purchase Date _____

Purchased From _____



**PIONEER ELECTRONICS (USA) INC.
GARANTIE LIMITÉE**

GARANTIE VALIDE UNIQUEMENT DANS LE PAYS D'ACHAT DU PRODUIT

GARANTIE

Pioneer Electronics (USA) Inc. (ci-après « Pioneer ») garantit que les appareils électroniques, haut-parleurs et accessoires automobiles/marins Pioneer® distribués par Pioneer aux États-Unis et au Canada, s'ils sont installés et utilisés conformément au manuel de l'utilisateur qui accompagne l'appareil et ne fonctionnent pas correctement dans des conditions normales d'utilisation en raison d'un défaut de fabrication, seront réparés ou remplacés par un appareil de valeur comparable, à la discrétion de Pioneer, sans frais de pièces ou de réparation. Les appareils de remplacement et/ou pièces fournies en vertu de cette garantie peuvent être neufs ou remis à neuf, à la discrétion de Pioneer.

Cette garantie limitée s'applique au propriétaire initial ou à tout propriétaire ultérieur de ce produit Pioneer pendant la période de garantie, sous réserve que le produit ait été acheté d'un détaillant Pioneer autorisé aux États-Unis ou au Canada. **Vous devez fournir un reçu de caisse ou autre preuve d'achat valide indiquant la date de l'achat initial. Si une réparation s'avère nécessaire, le produit doit être expédié dans la période de garantie, frais de port prépayés, uniquement depuis le pays de l'achat, et tel qu'expliqué dans le présent document. Vous serez responsable du retrait et de l'installation du produit.** Pioneer paiera les frais de retour du produit réparé ou de remplacement, à l'intérieur du pays d'achat.

PÉRIODE DE GARANTIE DU PRODUIT (La garantie prend effet à compter de la première vente au détail)

	Pièces	Main d'oeuvre
Appareils électroniques, haut-parleurs et accessoires automobiles/marins	1 an	1 an
Systèmes de détection d'angles morts	3 ans	3 ans

ÉLÉMENTS NON COUVERTS PAR LA GARANTIE

Cette garantie limitée s'applique aux produits Pioneer achetés d'un détaillant Pioneer autorisé. **SI CE PRODUIT A ÉTÉ ACHÉTÉ DE TOUTE AUTRE SOURCE, IL N'Y A PAS DE GARANTIES, EXPLICITES OU IMPLICITES, Y COMPRIS LES GARANTIES IMPLICITES DE QUALITÉ MARCHANDE ET GARANTIES IMPLICITES D'ADAPTATION À UN USAGE PARTICULIER, ET CE PRODUIT EST VENDU « TEL QUEL » ET « AVEC TOUS SES DÉFAUTS ».** PIONEER NE SERA RESPONSABLE D'AUCUN DOMMAGE CONSÉCUTIF ET/OU ACCESSOIRE. Certains États et certaines provinces n'autorisent pas l'exclusion ou la limitation des dommages consécutifs ou indirects, par conséquent, la limitation ou l'exclusion indiquée plus haut peut ne pas s'appliquer à vous.

Pioneer ne garantit aucun des produits énumérés ci-dessus s'ils sont utilisés à des fins commerciales ou professionnelles, ou dans toute application industrielle ou commerciale. Cette garantie ne s'applique pas si le produit a été soumis à une puissance nominale excédant celle indiquée dans les documents s'y appliquant. Cette garantie ne couvre pas les rayures ou tout autre élément esthétique ; les dommages ou défauts résultant de retouches ou modifications non autorisées par écrit par Pioneer ; les accidents, collisions, usages inappropriés ou abusifs ; l'utilisation non autorisée de pièces ou de main-d'œuvre ; l'installation ou la maintenance inadéquate ; les dommages causés par la foudre ou la surtension ; les dommages découlant de fuites ; les dommages découlant de piles défectueuses ; ou l'utilisation de piles non conformes à celles spécifiées dans le manuel de l'utilisateur. Cette garantie ne couvre pas le coût des pièces ou de la main-d'œuvre qui seraient autrement offertes sans frais en vertu de la présente garantie, si elles sont obtenues auprès d'une source autre que Pioneer. Les numéros de série modifiés, oblitérés ou enlevés annulent cette garantie.

INVALIDITÉ DE TOUTES AUTRES GARANTIES

DANS TOUTE LA MESURE AUTORISÉE PAR LA LOI, SAUF DISPOSITION CONTRAIRE DANS LE PRÉSENT DOCUMENT, PIONEER NE FAIT AUCUNE REPRÉSENTATION ET N'OFFRE AUCUNE GARANTIE, NI N'ACCEPTÉ AUCUNE CONDITION CONCERNANT CE PRODUIT. PIONEER LIMITE SES OBLIGATIONS EN VERTU DE TOUTES GARANTIES ET CONDITIONS IMPLICITES, Y COMPRIS, MAIS SANS S'Y LIMITER, LES GARANTIES ET CONDITIONS, EXPRESSES OU IMPLICITES, DE COMMERCIALITÉ ET D'ADAPTATION À UN USAGE PARTICULIER, À UNE PÉRIODE N'EXCÉDANT PAS LA PÉRIODE DE GARANTIE. AUCUNE GARANTIE OU CONDITION NE S'APPLIQUERA APRÈS LA PÉRIODE DE GARANTIE. Certains états et certaines provinces n'autorisent pas les limitations sur la durée d'une garantie implicite. Par conséquent, il se pourrait que certaines des limitations ou exclusions précitées ne s'appliquent pas à vous. Cette garantie vous confère des droits spécifiques légaux, mais vous pouvez bénéficier d'autres droits qui peuvent varier selon les États ou les provinces. Dans la mesure où toute disposition de cette garantie limitée est considérée comme invalide ou inexécutable en vertu du droit applicable, elle sera sans effet sur les autres dispositions, qui resteront pleinement en vigueur.

DEMANDE DE SERVICE

Aux États-Unis et au Canada, pour recevoir un service de garantie vous devez présenter votre reçu de caisse indiquant le lieu et la date de la transaction d'origine.

Pour toute demande de service, veuillez contacter :

Votre détaillant Pioneer autorisé - Votre détaillant Pioneer peut réparer ou remplacer votre appareil ou vous mettre en contact avec une entreprise de services Pioneer autorisée. Vous devriez trouver les coordonnées (numéro de téléphone, numéro de télécopieur, adresse de courriel, etc.) de votre détaillant sur votre reçu de caisse.

Support à la clientèle Pioneer - peut vous conseiller sur le choix de l'option de service optimal pour votre modèle et votre région géographique. Appelez-nous au **1-800-421-1404** ou visitez notre site Web à **www.pioneerelectronics.com** (pour les États-Unis) ou **http://www.pioneerelectronics.ca** (pour le Canada), cliquez sur « **Soutien** », puis sélectionnez « **Contactez-nous** ».

Votre entreprise de services Pioneer autorisée - peut effectuer des réparations pour la plupart des produits électroniques automobiles/marins, des haut-parleurs et des accessoires et peut vous conseiller sur le choix d'autres options, selon le cas. Visitez le site Web de Pioneer, cliquez sur « **Soutien** », puis sélectionnez « **Trouver un Centre de service** ».

Expédition de votre appareil aux fins de service — VOUS DEVEZ D'ABORD CONTACTER PIONEER POUR OBTENIR UNE AUTORISATION DE RETOUR. VEUILLEZ NE PAS ENVOYER VOTRE PRODUIT SANS AVOIR D'ABORD CONTACTÉ LE SERVICE À LA CLIENTÈLE. Si vous avez un numéro d'autorisation de retour, veuillez emballer le produit soigneusement et l'envoyer, frais de port prépayés avec un service d'expédition traçable et assurable, à une société de services Pioneer autorisée ou à Pioneer. Utilisez des matériaux d'emballage coussinés adéquats pour éviter les dommages pendant le transport. Incluez votre nom, votre adresse et un numéro de téléphone où nous pouvons vous joindre pendant les heures de bureau.

Pour toute question concernant votre produit, veuillez contacter le soutien à la clientèle Pioneer comme décrit ci-dessus ou écrivez-nous à :

Customer Support, Pioneer Electronics (USA) Inc., P.O. Box 1720, Long Beach, California 90801 U.S.A.

RÈGLEMENT DES CONFLITS

Dans le cas d'un conflit entre vous et Pioneer après notre réponse à votre demande initiale adressée service à la clientèle (Customer Support), Pioneer met à votre disposition son Programme de résolution des plaintes pour résoudre le conflit. Le Programme de résolution des plaintes est disponible sans frais. Aux États-Unis, vous êtes tenu de recourir au Programme de règlement des plaintes avant d'exercer vos droits ou d'exiger réparation en vertu de la loi sur la garantie « Magnuson-Moss Warranty Act », mais vous êtes en droit d'engager une action en justice en vertu des lois de l'État sans passer par le Programme de résolution des plaintes. Pour avoir recours au Programme de résolution des plaintes, composez le 1-800-421-1404 et décrivez au représentant du service à la clientèle le problème que vous rencontrez et les démarches que vous avez entreprises pour faire réparer le produit pendant la période de garantie, et donnez-lui le nom du détaillant Pioneer autorisé auprès duquel vous vous êtes procuré le produit Pioneer. Une fois que votre plainte a été expliquée au représentant, un numéro de résolution vous sera communiqué. Pioneer étudiera le conflit et, dans un délai de quarante (40) jours après la réception de votre plainte, (1) répondra à votre plainte par écrit pour vous aviser des démarches qu'elle entreprendra pour résoudre le conflit, et indiquera combien de temps ces démarches prendront ; ou (2) répondra à votre plainte par écrit pour vous indiquer les raisons pour lesquelles Pioneer n'entreprendra aucune démarche.

ENREGISTREZ LE LIEU ET LA DATE D'ACHAT. CONSERVEZ CES INFORMATIONS ET VOTRE REÇU DE CAISSE DANS UN ENDROIT SÛR

No. de Modèle. _____ No. de série _____ Date d'achat _____

Acheté de _____