

Pioneer

DIGITAL MEDIA RECEIVER
RÉCEPTEUR NUMÉRIQUE MULTIMÉDIA
RECEPTOR DE MEDIOS DIGITALES

MVH-S320BT
MVH-S322BT

Operation Manual
Mode d'emploi
Manual de operación

pandora®



 **Bluetooth®**



Important (Serial number)

The serial number is located on the bottom of this unit. For your own security and convenience, be sure to record this number on the enclosed warranty card.



Important (Numéro de série)

Le numéro de série se trouve au bas de cet appareil. Pour votre sécurité et votre commodité, veuillez à noter ce numéro sur la carte de garantie fournie.



Importante (Número de serie)

El número de serie se encuentra en la parte inferior de esta unidad. Por su propia seguridad y comodidad, asegúrese de anotar este número en la tarjeta de garantía que se adjunta.

Table of Contents

Getting Started	3
Radio	7
USB/iPhone®/AUX.....	8
Bluetooth	10
Pandora®	14
Spotify®	15
Using Pioneer Smart Sync/APP.....	17
Audio Adjustments	20
Settings	21
FUNCTION settings	21
AUDIO settings	22
SYSTEM settings	25
ILLUMINATION settings.....	27
MIXTRAX settings.....	27
Additional Information	29

About this manual:

- In the following instructions, a USB memory or USB audio player are referred to as "USB device".

Getting Started

Basic operation

MVH-S322BT/S320BT

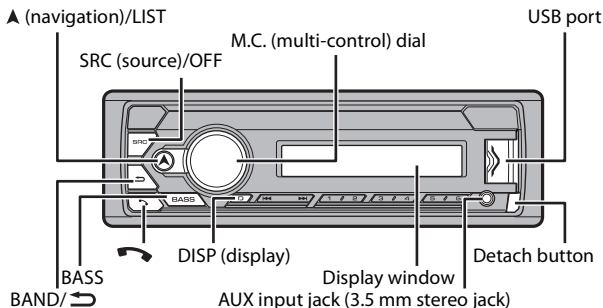

Optional remote control

The remote control CD-R510 is sold separately.





Frequently used operations

Purpose	Operation
Turn on the power*	Press SRC/OFF to turn on the power. Press and hold SRC/OFF to turn off the power.
Adjust the volume	Turn the M.C. dial.
Select a source	Press SRC/OFF repeatedly.
Change the display information	Press DISP repeatedly.
Return to the previous display/list	Press BAND/ ↶ .
Return to the normal display from the menu	Press and hold BAND/ ↶ .
Change the display brightness	Press and hold BAND/ ↶ .
Answering a call	Press any button.

Purpose	Operation
Ending a call	Press  .
Boost the bass level	Press BASS . • You can select the bass level ([HI] or [LOW]) in [D.BASS] (page 24).

* When this unit's blue/white lead is connected to the vehicle's auto-antenna relay control terminal, the vehicle's antenna extends when this unit's source is turned on. To retract the antenna, turn the source off.

Display indication

Indication	Description
	Appears when a lower tier of the menu or folder exists.
BASS	Appears when the BASS function is activated.
	Appears when random/shuffle play is set (except when BT AUDIO is selected as the source).
	Appears when repeat play is set (except when BT AUDIO is selected as the source).
	Appears when a Bluetooth connection is made (page 10).
APP	Appears when a Pioneer Smart Sync connection is made (page 17).

Detaching the front panel

Detach the front panel to prevent theft. Remove any cables and devices attached to the front panel and turn off the unit before detaching it.

Detach

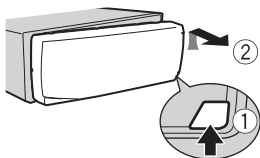

Attach

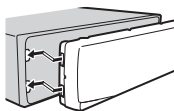

Important

- Avoid subjecting the front panel to excessive shock.
- Keep the front panel out of direct sunlight and high temperatures.
- Always store the detached front panel in a protective case or bag.

Resetting the microprocessor

The microprocessor must be reset in the following situations:

- Before using this unit for the first time after installation
- If the unit fails to operate properly
- When strange or incorrect messages appear on the display

- 1 Remove the front panel (page 4).
- 2 Press the **RESET** button with a pointed instrument longer than 8 mm.

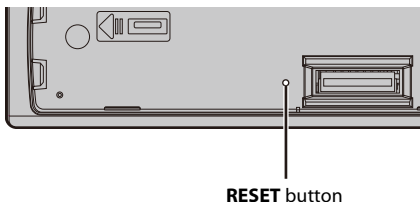

Setup menu

When you turn the ignition switch to ON after installation, the setup menu appears in the display.

- 1 Turn the **M.C.** dial to select the options, then press to confirm.
To proceed to the next menu option, you need to confirm your selection.

Menu Item	Description
LANGUAGE [ENG](English), [ESP](Spanish), [FRA] (Canadian French)	Select the language to display the text information from a compressed audio file.
CLOCK SET	Set the clock. 1 Turn the M.C. dial to adjust the hour, then press to confirm. The indicator moves to the minute setting automatically. 2 Turn the M.C. dial to adjust the minute, then press to confirm.

- 2 [QUIT :YES] appears.
To return to the first item of the setup menu, turn the **M.C.** dial to select [QUIT :NO], then press to confirm.

3 Press the M.C. dial to confirm the settings.

NOTE

These settings can be made at any time from the SYSTEM settings (page 25).

Canceling the demonstration display (DEMO OFF)

- 1 Press the M.C. dial to display the main menu.
- 2 Turn the M.C. dial to select [SYSTEM], then press to confirm.
- 3 Turn the M.C. dial to select [DEMO OFF], then press to confirm.
- 4 Turn the M.C. dial to select [YES], then press to confirm.

INITIAL settings



- 1 Press and hold SRC/OFF until the unit turns off.
- 2 Press the M.C. dial to display the main menu.
- 3 Turn the M.C. dial to select [INITIAL], then press to confirm.
- 4 Turn the M.C. dial to select an option, then press to confirm.

Menu Item	Description
SP-P/O MODE [REAR/SUB.W]	Select when there is a full-range speaker connected to the rear speaker output leads and there is a subwoofer connected to the RCA output.
[SUB.W/SUB.W]	Select when there is a passive subwoofer connected directly to the rear speaker output leads and there is a subwoofer connected to the RCA output.
[REAR/REAR]	Select when there are full-range speakers connected to the rear speaker output leads and RCA output. If there is a full-range speaker connected to the rear speaker output leads, and the RCA output is not used, you may select either [REAR/SUB.W] or [REAR/REAR].
SYSTEM UPDATE [SYSTEM INFO], [S/W UPDATE]	Select [SYSTEM INFO] to confirm the latest system information on the unit. Select [S/W UPDATE] to update the unit to the latest software and initialize the unit settings. For details on the latest software and updating, visit our website.
SYSTEM RESET [YES], [NO]	Select [YES] to initialize the unit settings. The unit will be restarted automatically.



Radio

The tuner frequencies on this unit are allocated for use in North America. Use in other areas may result in poor reception.



Receiving preset stations

- 1 Press **SRC/OFF** to select [RADIO].
- 2 Press **BAND/**  to select the band from [FM1], [FM2], [FM3] or [AM].
- 3 Press a number button (1/  to 6/ ).

TIP







The /  buttons can be also used to select a preset station when [SEEK] is set to [PCH] in the FUNCTION settings (page 22).

Best stations memory (BSM)

The six strongest stations are stored on the number buttons (1/  to 6/ .

- 1 After selecting the band, press the **M.C.** dial to display the main menu.
- 2 Turn the **M.C.** dial to select [FUNCTION], then press to confirm.
- 3 Turn the **M.C.** dial to select [BSM], then press to confirm.



To seek a station manually

- 1 After selecting the band, press /  to select a station.
Press and hold /  then release to seek an available station. Scanning stops when the unit receives a station. To cancel seek tuning, press / .

NOTE

[SEEK] needs to be set to [MAN] in the FUNCTION settings (page 22).

To store stations manually

- 1 While receiving the station you want to store, press and hold one of the number buttons (1/  to 6/ ) until it stops flashing.

USB/iPhone®/AUX

(iPhone source is not available when [USB MTP] is set to [ON] in the SYSTEM settings (page 26).)

Playing back

Disconnect headphones from the device before connecting it to the unit.

USB devices (including Android™)/iPhone

- 1 Open the USB port cover.
- 2 Plug in the USB device/iPhone using an appropriate cable.

NOTE

To automatically switch to USB source when a USB device/iPhone is connected to the unit, set [USB AUTO] to [ON] in the SYSTEM settings (page 26).

CAUTION

Use a USB cable (sold separately) to connect the USB device as any device connected directly to the unit will protrude out from the unit, which could be dangerous.

Before removing the device, stop playback.

AOA connections

A device running Android OS 4.1 or later installed and also supports AOA (Android Open Accessory) 2.0 can be connected to the unit via AOA, using the cable supplied with the device.

NOTE

If you use an AOA connection, [APP CONTROL] needs to be set to [WIRED] (page 26) and [USB MTP] needs to be set to [OFF] (page 26) in the SYSTEM settings.

MTP connection

A device installed with Android OS 4.0 or most of later versions can be connected to the unit via MTP, using the cable supplied with the device. However, depending on the connected device, OS version or the numbers of the files in the device, audio files/songs may not be able to be played back via MTP. Note that MTP connection is not compatible with WAV file formats and FLAC file formats, and cannot be used with the MIXTRAX function.

NOTE

If you use an MTP connection, [USB MTP] needs to be set to [ON] in the SYSTEM settings (page 26).

AUX

- 1 Insert the stereo mini plug into the AUX input jack.

2 Press **SRC/OFF** to select **[AUX IN]** as the source.

NOTE

If **[AUX]** is set to **[OFF]** in the **SYSTEM** settings, **[AUX IN]** cannot be selected as a source (page 25).

Operations

You can make various adjustments in the **FUNCTION** settings (page 21) (except for **AUX IN/USB** source).

Note that the following operations do not work for an **AUX** device. To operate an **AUX** device, use the device itself.

Purpose	Operation
Select a folder*1	Press 1/▲ or 2/▼ .
Select a track/song (chapter)	Press ◀◀ or ▶▶ .
Fast forward or reverse*2	Press and hold ◀◀ or ▶▶ .
Search for a file from a list (USB only)	<ol style="list-style-type: none"> 1 Press and hold ▲ to display the list. 2 Turn the M.C. dial to select the desired file (folder) name or category, then press to confirm. 3 Turn the M.C. dial to select the desired file, then press to confirm. Playback starts.
View a list of the files in the selected folder/category*1	Press the M.C. dial when a folder/category is selected.
Play a song in the selected folder/category*1	Press and hold the M.C. dial when a folder/category is selected.
Repeat play	Press 6/↶ .
Random/shuffle play	Press 5/↷ .
Pause/resume playback	Press 4/PAUSE .
Return to root folder (USB only)*1	Press and hold 1/▲ .

*1 Compressed audio files only

*2 When you use the fast forward or reverse function while playing a **VBR** file, the playback time may be not correct.

About MIXTRAX (USB/iPhone only)

The **MIXTRAX** function creates a non-stop mix of your music library. For details on **MIXTRAX** settings, see page 27.

NOTES

- iPhone needs to be connected with Pioneer Smart Sync via USB for using this function (page 17).

- Depending on the file/song, sound effects may not be available.

1 Press **3/MIX** to turn **MIXTRAX** on/off.

Bluetooth

Bluetooth connection

Important

If ten or more Bluetooth devices (e.g. a phone and separate audio player) are connected, they may not work properly.

TIP

The next connection to the unit is performed automatically if the Bluetooth device has been connected previously in the following steps.

1 Turn on the **Bluetooth** function of the device.

If you make a Bluetooth connection from the device, proceed to step 4.

2 Press  to display the **[ADD DEVICE]** setting.

The unit starts to search for available devices, then displays them in the device list.

- To cancel searching, press the **M.C.** dial.
- If the desired device is not in the list, select **[RE-SEARCH]**.
- If there is no device available, **[NOT FOUND]** appears in the display.
- If there is already a connected device, the phone menu appears by pressing .

3 Turn the **M.C.** dial to select a device from the device list, then press to confirm.

Press and hold the **M.C.** dial to switch the displayed device information between the Bluetooth device address and device name.

If you make a Bluetooth connection from the unit, proceed to step 5.

4 Select the unit name shown in the device display.

5 Make sure the same 6-digit number appears on this unit and the device, then select **[YES]** if the 6-digit numbers displayed on this unit and the device are the same.

Bluetooth telephone

First, make a Bluetooth connection with the Bluetooth telephone (page 10). Up to two Bluetooth telephones can be connected simultaneously.

Important

- Leaving the unit on standby to connect to your phone via Bluetooth while the engine is not running can drain the vehicle's battery.
- Be sure to park your vehicle in a safe place and apply the parking brake before operation.

To make a phone call

- 1 Press  to display the phone menu.

When two phones are connected, a phone name appears first then a phone menu will display. To switch to another phone, press  again.

- 2 Turn the **M.C. dial** to select [RECENTS] or [PHONE BOOK], then press to confirm. If you select [PHONE BOOK], proceed to step 4.
- 3 Turn the **M.C. dial** to select [MISSED], [DIALED] or [RECEIVED], then press to confirm.
- 4 Turn the **M.C. dial** to select a name or phone number, then press to confirm. The phone call starts.





To answer an incoming call

- 1 Press any button when a call is received.

TIP

When two phones are connected to the unit via Bluetooth and there is an incoming call while one phone is being used for a call, a message will appear in the display. To answer that incoming call, you need to end the existing call.

Basic operations

Purpose	Operation
End a call	Press  .
Reject an incoming call	Press and hold  when a call is received.
Switch between the current caller and a caller on hold	Press the M.C. dial .
Cancel a caller on hold	Press and hold  .
Adjust the volume of the caller's voice (When private mode is on, this function is not available.)	Turn the M.C. dial during the call.
Turn the private mode on or off	Press BAND/  during the call.

To preset phone numbers

- 1 Select a phone number from a phone book or call history.

2 Press and hold one of the number buttons (1/∧ to 6/↩).

The contact is stored in the selected preset number.

To make a call using a preset number, press one of the number buttons (1/∧ to 6/↩), then press the **M.C.** dial, while the phone menu is displayed.

Voice recognition

This function is only available when an iPhone/Android device equipped with voice recognition is connected to the unit via Bluetooth.

1 Press and hold and then talk into the microphone to input voice commands.

To exit the voice recognition mode, press **BAND/↶**.

NOTE

For details on the voice recognition features, refer to the manual supplied with your device.

TIP

When a Pioneer Smart Sync connection is made (page 17), you can also use the voice recognition function from Pioneer Smart Sync installed on your iPhone/Android device by pressing and holding . For details on the voice recognition features, see the application's help section.

Phone menu

1 Press to display the phone menu.

Menu Item	Description
RECENTS	Display the missed call history.
[MISSED]	
[DIALED]	Display the dialed call history.
[RECEIVED]	Display the received call history.
PHONE BOOK	Display the contacts in your phone.
PRESET 1-6	Recall the preset phone numbers. You can also recall the preset phone numbers by pressing one of the number buttons (1/∧ to 6/↩).
A.ANSR*	Select [ON] to answer an incoming call automatically.
[ON], [OFF]	
PB INVT	Invert the order of names in the phone book (name view).
DEVICELIST	Display the list of paired Bluetooth devices. "*" appears on the device name when the Bluetooth connection is established. When no device is selected in the device list, this function is not available.

Menu Item	Description
DEL DEVICE [DELETE YES], [DELETE NO]	Delete the device information.
ADD DEVICE	Register a new device.
DEV. INFO	Switch the device information on the display between the device name and Bluetooth device address.

* If two phones are connected, this function does not work on incoming calls that are received while one of the phones is being used for a call.

Bluetooth audio

Important

- Depending on the Bluetooth audio player connected to this unit, the available operations will be limited to the following two levels:
 - A2DP (Advanced Audio Distribution Profile) can only play back songs on your audio player.
 - AVRCP (Audio/Video Remote Control Profile) can perform functions such as playback, pause, select song, etc.
- The sound of the Bluetooth audio player will be muted when the phone is in use.
- When the Bluetooth audio player is in use, you cannot connect to a Bluetooth telephone automatically.
- Depending on the type of Bluetooth audio player you have connected to this unit, operation and information displayed may vary based on availability and functionality.

1 Make a Bluetooth connection with the Bluetooth audio player.

2 Press **SRC/OFF** to select [BT AUDIO] as the source.

3 Press **BAND/↶** to start playback.

NOTE

You must reconnect the Bluetooth connection when the source is switched or the unit is turned off.

TIP

When more than two and up to five devices are registered to the unit via Bluetooth, you can switch the Bluetooth device by playing back songs on the device. By doing so, playing back a song from the Bluetooth device of each passenger is easily available. However, depending on the usage conditions, multiple connections may not be available and the audio files/songs may not be able to be played back properly.

Basic operations

You can make various adjustments in the FUNCTION settings (page 21).

Purpose	Operation
Fast forward or reverse	Press and hold ⏮ or ⏭ .

Purpose	Operation
Select a track	Press ⏮ or ⏭ .
Repeat play*	Press 6 / ↺ .
Random play*	Press 5 / ↻ .
Pause/resume playback	Press 4 / PAUSE .
Search for a file from a list	<ol style="list-style-type: none"> 1 Press and hold ▲ to display a list. 2 Turn the M.C. dial to select the desired folder name, then press to confirm. 3 Turn the M.C. dial to select the desired file, then press to confirm. Playback starts.

* Depending on the connected device, these operations may not be available.

Pandora®

(Not available when [USB MTP] is set to [ON] in the SYSTEM settings (page 26).)

Pandora music is a music service not affiliated with Pioneer. More information is available at <http://www.pandora.com>.

The Pandora mobile application is available for iPhone and Android phones. Please visit www.pandora.com/everywhere/mobile for the latest compatibility information.

Listening to Pandora

Update the firmware of the Pandora application to the latest version before use.

- 1 **Connect this unit with the mobile device.**
 - iPhone via USB (page 8)
 - iPhone/Android device via Bluetooth (page 10)
- 2 Press **SRC/OFF** to select [PANDORA].
- 3 Press and hold **1**/**∧** to display [APP CONTROL].
- 4 Turn the **M.C.** dial to select one of the below.
 - Select [WIRED] for the USB connection.
 - Select [BLUETOOTH] for the Bluetooth connection.
- 5 Press **SRC/OFF** to select [PANDORA].
- 6 Launch the Pandora application on the mobile device and start playback.

NOTE

When you connect a mobile device other than an iPhone/Android device, it may not operate correctly depending on your mobile device.

Basic operations

You can make various adjustments in the FUNCTION settings (page 21).

Purpose	Operation
Skip a track	Press ▶▶ .
Switch between Shuffle and the station	Press and hold ▲ , then turn the M.C. dial to select the Shuffle or the desired station.
Change the sort order	Press and hold ▲ , then select one of the following. [ABC] : Sort the items in the list alphabetically. [DATE] : Sort the items in the list in order of the dates on which the items were created.
Play	When Shuffle or the station is selected, press the M.C. dial.
Delete a station	<ol style="list-style-type: none"> When the station is selected, press and hold the M.C. dial. [DELETE YES] appears. Press the M.C. dial. To cancel, press BAND/↶ in step 1.
Pause/resume playback	Press 4/PAUSE .
Thumbs Up	Press 1/▲ .
Thumbs Down	Press 2/▼ .
Create a new station based on the track currently being played	Press and hold 5/🔍 .
Create a new station based on the artist currently being played	Press and hold 6/🔍 .
Store the track information currently being played in your Pandora account.	<ol style="list-style-type: none"> Press and hold 3/MIX. [BOOKMARK] appears. Press the M.C. dial.

NOTE

Some functions of Pandora may not be operated from the unit.



(Not available when [USB MTP] is set to [ON] in the SYSTEM settings (page 26).)

Spotify is a music streaming distribution service not affiliated with Pioneer. More information is available at <http://www.spotify.com>.

The Spotify application is available for compatible smartphones, please visit <https://support.spotify.com/> for the latest compatibility information.

To enjoy Spotify as you drive, first download the Spotify app to your iPhone or Android device. You can download it on the iTunes® App Store® or Google Play™. Choose a free account or a paid Premium account, either in the app or at spotify.com. A Premium account gives you more features, like offline listening.

Important

- This product incorporates Spotify software which is subject to 3rd party licenses found here: www.spotify.com/connect/third-party-licenses.
- For information on the countries and regions where Spotify can be used, take a look at <https://spotify.com/us/select-your-country/>.

Listening to Spotify

Update the firmware of the Spotify application to the latest version before use.

- 1 Connect this unit with the mobile device.**
 - iPhone via USB (page 8)
 - iPhone/Android device via Bluetooth (page 10)
- 2 Press SRC/OFF to select [SPOTIFY].**
- 3 Press and hold 1/ ^ to display [APP CONTROL].**
- 4 Turn the M.C. dial to select one of the below.**
 - Select [WIRED] for the USB connection.
 - Select [BLUETOOTH] for the Bluetooth connection.
- 5 Press SRC/OFF to select [SPOTIFY].**
- 6 Launch the Spotify application on the mobile device and start playback.**

NOTE



When you connect a mobile device other than an iPhone/Android device, it may not operate correctly depending on your mobile device.

Basic operations

You can make various adjustments in the FUNCTION settings (page 21).

NOTE

The available operations may vary according to the type of contents (track/album/artist/playlist/radio) you want to play.

Purpose	Operation
Skip a track	Press  or  .

Purpose	Operation
Search for a track from a list	<ol style="list-style-type: none"> 1 Press and hold ▲ to display the list. 2 Turn the M.C. dial to select the desired category, then press to confirm. 3 Turn the M.C. dial to select the desired file, then press to confirm. Playback starts.
Pause/resume playback	Press 4/PAUSE .
Thumbs Up (Only for radio)	Press 1/▲ .
Thumbs Down (Only for radio)	Press 2/▼ .
Random play (Only for track/album/artist/playlist)	Press 5/🎲 .
Repeat play (Only for track/album/artist/playlist)	Press 6/🔄 .
Start a radio channel based on the song currently being played.	<ol style="list-style-type: none"> 1 Press and hold 5/🎲 to start a radio. 2 Press the M.C. dial. <ul style="list-style-type: none"> • This function may not be available depending on the selected song.

NOTE

Some functions of Spotify may not be operated from the unit.

Using Pioneer Smart Sync/APP

Pioneer Smart Sync is the application that intelligently brings your maps, messages, and music together in the vehicle.

You can operate the unit from Pioneer Smart Sync installed on an iPhone/Android device. In some cases, you can control aspects of the application, such as source selection, pause, etc., by using the unit.

For details on what operations are available on the application, see the application's help section.

NOTE

The APP source is not available when a Pioneer Smart Sync connection is not made or [USB MTP] is set to [ON] in the SYSTEM settings (page 26).

**WARNING**

Do not attempt to operate the application while driving. Make sure to pull off the road and park your vehicle in a safe location before attempting to use the controls on the application.

For iPhone users

This function is compatible with iOS 10.3 or later.

You can download Pioneer Smart Sync on iTunes App Store.



For Android device users

For Bluetooth connections, this function is compatible with devices that have Android OS 5.0 or later installed.

For USB connections, this function is compatible with a phone that runs Android 5.0 or later up to 7.1.2 and also supports AOA (Android Open Accessory) 2.0. However, the compatibility depends on the smartphone.

You can download Pioneer Smart Sync on Google Play.



NOTE

Some Android devices connected via AOA 2.0 may not work properly or emit sounds due to their own software design, regardless of the OS version.

What kind of function does the application have?

Promoting the use of the unit

The interface of the unit can be evolved by using your iPhone/Android device.

Image (example):

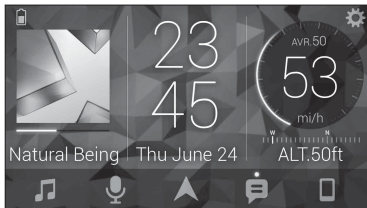

Examples:

- Selecting a source of the unit

- Listening to the music on your iPhone/Android device
- Controlling the sound field intuitively
- Controlling your connected Bluetooth device

Extending the functions of the unit by using the application

The following functions, which are unavailable on the unit alone, are available by making a Pioneer Smart Sync connection.

Menu Item (example)	Description
Using a navigation application	You can specify and start the navigation application installed on your device.
Message reading	You can read messages received from the apps installed on your device.
31 Band EQ setting	You can select an equalizer band from the 31-band graphic equalizer (13-band for not using the Pioneer Smart Sync connection).
Super "Todoroki" Sound	You can boost the bass level more dynamically than when not using the Pioneer Smart Sync connection.
Easy Sound Fit	You can perform the time alignment setting easily by selecting your vehicle type.

NOTES

- Some functions may be restricted depending on the connection conditions with the application.
- The 31 Band EQ setting is converted into 13 bands when a music source from this product is engaged.

TIP

It is recommended to enter the search term "Pioneer Smart Sync" in the search field to search for the application.

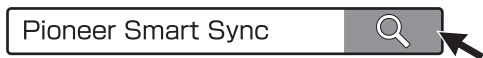

Making a connection with Pioneer Smart Sync

- 1 Press the M.C. dial to display the main menu.
- 2 Turn the M.C. dial to select [SYSTEM], then press to confirm.
- 3 Turn the M.C. dial to select [APP CONTROL], then press to confirm.
- 4 Turn the M.C. dial to select one of the below.
 - Select [WIRED] for the USB connection.
 - Select [BLUETOOTH] for the Bluetooth connection.

5 Turn the **M.C.** dial to select [AUTO APP CONN], then press to confirm.

6 Turn the **M.C.** dial to select [ON], then press to confirm.

7 Connect this unit with the mobile device.

- iPhone/Android device via USB (page 8)
 - iPhone/Android device via Bluetooth (page 10)
- Pioneer Smart Sync on the device starts automatically.

NOTE

Regardless of whether the [AUTO APP CONN] setting is set to [ON] or [OFF], you can also perform the following to start Pioneer Smart Sync.

- For devices other than the USB-connected Android device, press **SRC/OFF** to select any source and press and hold the **M.C.** dial.
- For iPhone, launch Pioneer Smart Sync on the mobile device.

NOTES

- When you connect a mobile device other than an iPhone/Android device, it may not operate correctly depending on your mobile device.
- If Pioneer Smart Sync has not been installed on your iPhone/Android device yet, a message that prompts you to install the application will appear on your iPhone/Android device (except for the Android device connected via Bluetooth). Select [OFF] in [AUTO APP CONN] to clear the message (page 26).

Listening to music on your device

1 Press **SRC/OFF** to select [APP].

Audio Adjustments

You can also make various adjustments in the AUDIO settings (page 22).

Adjusting the cut-off frequency value and the slope value

You can adjust the cut-off frequency value and the slope value of each speaker.

The following speakers can be adjusted.

[FRONT], [REAR], [SUBWOOFER]

NOTE

[SUBWOOFER] can only be selected when [ON] is selected in [SUBWOOFER] (page 23).

1 Press the **M.C.** dial to display the main menu.

- 2 Turn the **M.C.** dial to select [AUDIO], then press to confirm.
- 3 Turn the **M.C.** dial to select [CROSSOVER], then press to confirm.
- 4 Turn the **M.C.** dial to select the speaker unit (filter) to be adjusted, then press to confirm.
- 5 Turn the **M.C.** dial to select [HPF] or [LPF] according to the speaker unit (filter), then press to confirm.
- 6 Turn the **M.C.** dial to select an appropriate cut-off frequency for the speaker unit (filter) selected in step 4, then press to confirm.
[25HZ] to [250HZ]
- 7 Turn the **M.C.** dial to select an appropriate slope for the speaker unit (filter) selected in step 4.
[-6] to [-24] (if you choose [FRONT] or [REAR])
[-6] to [-36] (if you choose [SUBWOOFER])

Settings

You can adjust various settings in the main menu.

- 1 Press the **M.C.** dial to display the main menu.
- 2 Turn the **M.C.** dial to select one of the categories below, then press to confirm.
 - FUNCTION settings (page 21)
 - AUDIO settings (page 22)
 - SYSTEM settings (page 25)
 - ILLUMINATION settings (page 27)
 - MIXTRAX settings (page 27)
- 3 Turn the **M.C.** dial to select the options, then press to confirm.

FUNCTION settings

The menu items vary according to the source.

Menu Item	Description
BSM RADIO	Store the six strongest stations on the number buttons (1/▲ to 6/↶) automatically.

Menu Item	Description
LOCAL <input type="button" value="RADIO"/>	
FM: [OFF], [LV1], [LV2], [LV3], [LV4] AM: [OFF], [LV1], [LV2]	Restrict the tuning station according to the signal strength.
SEEK <input type="button" value="RADIO"/>	
[MAN], [PCH]	Assign ◀◀ or ▶▶ buttons to seek the stations one by one (manual tuning) or select a station from the preset channels.
SAVE <input type="button" value="SPOTIFY"/>	
	Store the information about the song currently being played to your music list on Spotify.
UNSAVE <input type="button" value="SPOTIFY"/>	
	Remove the song information stored in [SAVE].
SEL DEVICE <input type="button" value="iPhone"/> <input type="button" value="PANDORA"/> <input type="button" value="BT AUDIO"/> <input type="button" value="SPOTIFY"/>	
	Connect a Bluetooth device in the list.
BOOKMARK <input type="button" value="PANDORA"/>	
	Store the track information currently being played in your Pandora account.
NEW STATION <input type="button" value="PANDORA"/>	
[FROM TRACK], [FROM ARTIST]	Create a new station based on the track or artist currently being played.
PLAY <input type="button" value="BT AUDIO"/>	
	Start playback.
STOP <input type="button" value="BT AUDIO"/>	
	Stop playback.

AUDIO settings

NOTE

[CHK APP SETTG.] may be displayed when the setting is performed from Pioneer Smart Sync.

Menu Item	Description
EQ SETTING	
[SUPER BASS], [POWERFUL], [DYNAMIC], [NATURAL], [VOCAL], [VIVID], [SET BY APP]*, [CUSTOM1], [CUSTOM2], [FLAT] * [SET BY APP] is displayed when the preset equalizer curve that is not available in the unit has been set from Pioneer Smart Sync.	Select or customize the equalizer curve. • When you select a setting other than [CUSTOM1], [CUSTOM2] and [SET BY APP], you can also customize the equalizer curve by pressing and holding the M.C. dial, then store the customized equalizer curve in [CUSTOM1].
Select an equalizer band and level for further customizing. Equalizer band: [50HZ] to [12.5kHz] Equalizer level: [-6] to [+6]	
FADER*1	
	Adjust the front and rear speaker balance.
BALANCE	
	Adjust the left and right speaker balance.
SUBWOOFER*2	
[ON], [OFF]	Set to [ON] when using a subwoofer speaker.
SUBWOOFER	
[NOR], [REV]	Select the subwoofer phase.
SPEAKER LEVEL	
Types of speaker: [FRONT L], [FRONT R], [REAR L], [REAR R], [SUBWOOFER] Output level: [-24] to [10]	Select a speaker unit (filter) and adjust the output level. • Each value you have adjusted changes when you change the [POSITION] setting (page 23).
CROSSOVER	
	Select a speaker unit (filter) to adjust the HPF or LPF cut-off frequency and the slope for each speaker unit. For details on the [CROSSOVER] setting, see page 20.
POSITION	
[OFF], [FRONT LEFT] (front seat left), [FRONT RIGHT] (front seat right), [FRONT] (front seats), [ALL]	Select a listening position to adjust the speakers' output levels automatically and add a delay time that corresponds to the number and locations of occupied seats.

Menu Item	Description
TIME ALGNMNT	
[INITIAL], [OFF], [CUSTOM]	Select or customize the time alignment settings to reflect the distance between the listener's position and each speaker.
Select a type of speaker and adjust the speaker distance for further customizing in [CUSTOM].	<ul style="list-style-type: none"> • Select [INITIAL] to initialize the setting value. • Select [OFF] to reset all setting values to 0. • The [CUSTOM] setting is available when [FRONT LEFT] or [FRONT RIGHT] is selected in [POSITION] (page 23). • The [CUSTOM] setting is not available when [OFF] is selected in [SUBWOOFER] (page 23).
Types of speaker: [FRONT L], [FRONT R], [REAR L], [REAR R], [SUBWOOFER]	
Speaker distance (inch): [140] to [0]	
SAVE SETTINGS	
[YES], [NO]	Save to later recall the following sound settings at their current values: [CROSSOVER], [SPEAKER LEVEL], [EQ SETTING], [POSITION], [TIME ALGNMNT], [D.BASS], [SUBWOOFER].
	<ul style="list-style-type: none"> • The settings that can be saved differ when a Pioneer Smart Sync connection is made.
LOAD SETTINGS	
	Load the sound settings, when you have already performed [SAVE SETTINGS].
D.BASS	
[OFF], [LOW], [HI]	Boost the bass level dynamically to offer an effect as if a subwoofer was added to the system.
LOUDNESS	
[OFF], [LOW], [MID], [HI]	Compensate for clear sound at low volume.
SLA	
[+4] to [-4]	Adjust the volume level for each source except FM.
	Each of the below combinations are set to the same setting automatically.
	<ul style="list-style-type: none"> • When making a USB connection, set USB, iPhone, PANDORA, APP, and SPOTIFY. • When making a Bluetooth connection, set BT AUDIO, iPhone, PANDORA, APP, and SPOTIFY.

Menu Item	Description
S.RTRV	
[1] (effective for low compression rates), [2] (effective for high compression rates), [OFF]	Enhance compressed audio and restore rich sound.

*1 Not available when [SUB.W/SUB.W] is selected in [SP-P/O MODE] in the INITIAL settings (page 6).

*2 Not available when [REAR/REAR] is selected in [SP-P/O MODE] in the INITIAL settings (page 6).

SYSTEM settings

You can also access to these menus when the unit is turned off.

Menu Item	Description
LANGUAGE	
[ENG](English), [ESP](Spanish), [FRA] (Canadian French)	Select the language to display the text information from a compressed audio file.
CLOCK SET	
[12H], [24H]	Set the clock (page 5). • This setting is not available when a Pioneer Smart Sync connection is made.
SCROLL SET	
[ONCE], [LOOP], [OFF]	Select the way to scroll the text in the display window.
BEEP TONE	
[ON], [OFF]	A beep can be heard when any button is pushed. Select [OFF] to disable this function.
INFO DISPLAY	
[SOURCE/SPEANA], [CLOCK/SPEANA], [SRC/LIVE FX], [CLOCK/LIVE FX], [SOURCE], [SPEANA], [OFF]	Display the item on the sub information display. • When [SOURCE/SPEANA] or [CLOCK/SPEANA] is selected, display the antenna instead of the speana on the radio source.
AUX	
[ON], [OFF]	Set to [ON] when using an auxiliary device connected to the unit.
BT AUDIO	
[ON], [OFF]	Set the Bluetooth signal on/off.

Menu Item	Description
PANDORA [ON], [OFF]	Set to [ON] when using the Pandora function.
SPOTIFY [ON], [OFF]	Set to [ON] when using the Spotify function.
BT MEM CLEAR [YES], [NO]	Clear the Bluetooth device data (device list, PIN code, call history, phone book, preset phone numbers) stored in the unit. [CLEARED] appears when data is successfully deleted.
APP CONTROL [WIRED], [BLUETOOTH]	Select the appropriate connection method according to your device. See page 26 for details on the connections for each device.
USB MTP [ON], [OFF]	Set to [ON] when using the MTP connection. The following sources are not available when the setting is set to [ON]. • APP, PANDORA, SPOTIFY, iPhone, and USB (AOA)
AUTO APP CONN [ON], [OFF]	Select [ON] to automatically launch Pioneer Smart Sync when the iPhone/Android device is connected to the unit.
USB AUTO [ON], [OFF]	Select [ON] to automatically switch to USB source when a USB device/iPhone is connected to the unit. Select [OFF] when a USB device/iPhone is being connected to the unit just for charging.

Information on the connections for each device

The available sources differ depending on the setting value.
Please set [APP CONTROL] according to the table for the source you want to use.
For details on Pioneer Smart Sync connection, see page 17.

When Pioneer Smart Sync connection is NOT performed

Setting Value	Device	Available source(s)
[WIRED]	iPhone	iPhone, PANDORA, SPOTIFY
	Android	USB (AOA)
[BLUETOOTH]	iPhone	iPhone, PANDORA, SPOTIFY
	Android	PANDORA, SPOTIFY

When Pioneer Smart Sync connection is performed

Setting Value	Device	Available source(s)
[WIRED]	iPhone	APP, PANDORA, SPOTIFY
	Android	APP
[BLUETOOTH]	iPhone	APP, PANDORA, SPOTIFY
	Android	APP, PANDORA, SPOTIFY

ILLUMINATION settings

Menu Item	Description
DIM SETTING	
[SYNC CLOCK], [MANUAL]	Select the way to change the display brightness.
BRIGHTNESS	
[1] to [10]	Change the display brightness. The available setting ranges differ depending on [DIM SETTING].

MIXTRAX settings

Menu Item	Description
SHORT PLAYBACK	
[1.0 MIN], [1.5 MIN], [2.0 MIN], [2.5 MIN], [3.0 MIN], [OFF]	Select the length of the playback time.

Menu Item	Description
MIX PATTERN	
[SOUND LEVEL]	Change the MIXTRAX special effects according to the audio level. The mix pattern changes according to the sound level.
[LOW PASS]	The mix pattern changes according to the bass level.
[RANDOM]	The mix pattern changes randomly according to the sound level mode and low pass mode.
DISPLAY FX	
[ON], [OFF]	Set the MIXTRAX special effects on/off.
CUT IN FX	
[ON], [OFF]	Turn the MIXTRAX sound effects on/off while manually changing the tracks.

Additional Information

Troubleshooting

The display automatically returns to the normal display.

- No operations have been made for about 30 seconds.
 - Perform an operation.

The repeat play range changes unexpectedly.

- Depending on the repeat play range, the selected range may change when another folder or track is being selected or during fast forwarding/reversing.
 - Select the repeat play range again.

A subfolder is not played back.

- Subfolders cannot be played when [FLD] (folder repeat) is selected.
 - Select another repeat play range.

The sound is intermittent.

- You are using a device, such as a cellular phone, that may cause audible interference.
 - Move electrical devices that may be causing the interference away from the unit.

The sound from the Bluetooth audio source is not played back.

- There is a call in progress on a Bluetooth-connected cellular phone.
 - The sound will be played back when the call is terminated.
- A Bluetooth-connected cellular phone is currently being operated.
 - Stop using the cellular phone.
- The connection between the unit and the cellular phone is not established correctly after a call made by a Bluetooth-connected cellular phone.

- Make a Bluetooth connection between the unit and the cellular phone again.

Error messages

Common

AMP ERROR

- This unit fails to operate or the speaker connection is incorrect.
- The protective circuit is activated.
 - Check the speaker connection.
 - Turn the ignition switch OFF and back to ON again. If the message remains, contact your dealer or an authorized Pioneer Service Station for assistance.

NO XXXX (NO TITLE, for example)

- There is no embedded text information.
 - Switch the display or play another track/file.

USB device/iPhone

FORMAT READ

- Sometimes there is a delay between the start of playback and when you start to hear any sound.
 - Wait until the message disappears and you hear sound.

NO AUDIO

- There are no songs.
 - Transfer the audio files to the USB device and connect.
- The connected USB device has security enabled.
 - Follow the USB device instructions to disable the security.

SKIPPED

- The connected USB device contains DRM protected files.
 - The protected files are skipped.

PROTECT

- All the files on the connected USB device are embedded with DRM.
 - Replace the USB device.

N/A USB

- The connected USB device is not supported by this unit.
 - Disconnect your device and replace it with a compatible USB device.

HUB ERROR

- The USB device connected via a USB hub is not supported by this unit.
 - Connect the USB device directly to this unit using a USB cable.

CHECK USB

- The USB connector or USB cable has short-circuited.
 - Check that the USB connector or USB cable is not caught in something or damaged.
- The connected USB device consumes more than maximum allowable current.
 - Disconnect the USB device and do not use it. Turn the ignition switch OFF and back to ACC or ON. Connect only compliant USB devices.

ERROR-19

- Communication failed.
 - Perform one of the following operations, then return to the USB source.
 - Disconnect the USB device.
 - Change to a different source.
- iPhone failure.
 - Disconnect the cable from the iPhone. Once the iPhone's main menu is displayed, reconnect the iPhone and reset it.

ERROR-23

- USB device was not formatted properly.
 - Format the USB device with FAT12, FAT16 or FAT32.

ERROR-16

- The iPhone firmware version is old.
 - Update the iPhone version.
- iPhone failure.
 - Disconnect the cable from the iPhone. Once the iPhone's main menu is displayed, reconnect the iPhone and reset it.

STOP

- There are no songs in the current list.
 - Select a list that contains songs.

NO BT DEVICE GO TO BT MENU TO REGISTER

- No Bluetooth device found.
 - Connect the unit and iPhone via Bluetooth (page 10).

CONN. FAILED PRESS BAND KEY TO RETRY

- Bluetooth connection with iPhone failed.
 - Press **BAND/**  to make a connection again.

DISCONNECTED PRESS BAND KEY TO RETRY

- Bluetooth connection lost.
 - Press **BAND/**  to make a connection again.

Bluetooth device**ERROR-10**

- The power failed for the Bluetooth module of the unit.
 - Turn the ignition switch OFF and back to ACC or ON.

Pandora

ERROR-19

- Communication failed.
 - Disconnect the cable from the device. Once the device's main menu is displayed, reconnect the device and reset it.
-

NOT FOUND

- The Pandora application has not started running yet.
 - Start up the Pandora application.
-

RATING ERROR

- The thumb rating operation was disabled.
 - Run the same command for another track.
-

CAN'T SKIP

- The skip operation was disabled.
 - Run the same command for another track.
-

THUMB ERROR

- Unable to save thumb rating.
 - Try again later.
-

BOOKMARK ERR

- Unable to save BookMark.
 - Try again later.
-

INOPERABLE

- The operation to save BookMark or add station was disabled.
 - Run the same command for another track.
-

UNABLE TO ADD

- Unable to add station.
 - Try again later.
-

SKIP LIMIT

- Due to music licensing restrictions, Pandora limits the total number of skips per hour.
-

- Wait until Pandora allows you to skip again.
-

UPDATE APP

- This version of the Pandora application is not supported.
 - Connect a device that has a compatible version of the Pandora application installed.
-

LOG IN ERROR

- Your Pandora account is not logged in.
 - Disconnect the cable from the device, and log in to your Pandora account. Then reconnect the device.
-

ERROR

- Device error message displayed in the Pandora application.
 - Check the connected device.
 - Pandora system is undergoing maintenance.
 - Try again later.
-

NO STATIONS

- No station found.
 - Create a station in the Pandora application on your connected device.
-

NO BT DEVICE GO TO BT MENU TO REGISTER

- No Bluetooth device found.
 - Connect the unit and the device via Bluetooth (page 10).
-

CONN. FAILED PRESS BAND KEY TO RETRY

- Bluetooth connection failed.
 - Press **BAND/**  to make a connection again.
-

CHECK APP PRESS BAND KEY TO RETRY

- Connection to the Pandora application failed.
 - Press **BAND/**  to make a connection again.
-

DISCONNECTED PRESS BAND KEY TO RETRY

- Bluetooth connection lost.
 - Press **BAND/**  to make a connection again.

STATION LIMIT

- A new station cannot be added.
 - Delete an old station to open a spot for a new one.

CANNOT DELETE

- The station could not be deleted.
 - Run the same command for another station.

BAD NETWORK

- The connected device is out of area.
 - Connect the device to a network.

UNAVAILAVLE

- The connected device is out of area.
 - Connect the device to a network.
- The operation was disabled.
 - Run the same command for another station.

CHECK APP

- An unknown error (including communication error) has occurred.
 - Follow the instructions that appear on the screen.

APP

CONNECT APP

- Pioneer Smart Sync connection is not made.
 - Make a connection with Pioneer Smart Sync (page 17).

Spotify

NOT FOUND

- The Spotify application has not started running yet.
 - Start up the Spotify application.

NO BT DEVICE GO TO BT MENU TO REGISTER

- No Bluetooth device found.
 - Connect the unit and the device via Bluetooth (page 10).

CONN. FAILED PRESS BAND KEY TO RETRY

- Bluetooth connection failed.
 - Press **BAND/**  to make a connection again.

CHECK APP PRESS BAND KEY TO RETRY

- Connection to the Spotify application failed.
 - Press **BAND/**  to make a connection again.

DISCONNECTED PRESS BAND KEY TO RETRY

- Bluetooth connection lost.
 - Press **BAND/**  to make a connection again.

CHECK APP

- An unknown error (including communication error) has occurred.
 - Follow the instructions that appear on the screen.

Handling guidelines

USB storage device

- Connections via USB hubs are not supported.
- Firmly secure the USB storage device before driving. Do not let the USB storage device fall onto the floor, where it may become jammed under the brake or accelerator pedal.
- Depending on the USB storage device, the following problems may occur.
 - Operations may vary.
 - The storage device may not be recognized.

- Files may not be played back properly.
- The device may cause audible interference when you are listening to the radio.

iPhone

- Do not leave the iPhone in places with high temperatures.
- Firmly secure the iPhone when driving. Do not let the iPhone fall onto the floor, where it may become jammed under the brake or accelerator pedal.
- Incompatible text saved on the iPhone will not be displayed by the unit.

Compressed audio compatibility

- Only the first 32 characters can be displayed as a file name (including the file extension) or a folder name.
- The unit may not work properly depending on the application used to encode WMA files.
- There may be a slight delay at the start of the playback of audio files embedded with image data, or audio files stored on a USB device with numerous folder hierarchies.

CAUTION

- Pioneer cannot guarantee compatibility with all USB mass storage devices, and assumes no responsibility for any loss of data on media players, smartphones, or other devices while using this product.
- Do not leave a USB device in any place that is subject to high temperatures.

WMA files

File extension	.wma
Bit rate	48 kbps to 320 kbps (CBR), 48 kbps to 384 kbps (VBR)

Sampling frequency	32 kHz, 44.1 kHz, 48 kHz
Windows Media™ Audio Professional, Lossless, Voice/DRM Stream/Stream with video	Not compatible

MP3 files

File extension	.mp3
Bit rate	8 kbps to 320 kbps (CBR), VBR
Sampling frequency	8 kHz to 48 kHz (32 kHz, 44.1 kHz, 48 kHz for emphasis)
Compatible ID3 tag version	1.0, 1.1, 2.2, 2.3, 2.4 (ID3 tag Version 2.x is given priority over Version 1.x.)
M3u playlist	Not compatible
MP3i (MP3 interactive), mp3 PRO	Not compatible

WAV files

- WAV file formats cannot be connected via MTP.

File extension	.wav
Quantization bits	8 and 16 (LPCM)
Sampling frequency	16 kHz to 48 kHz (LPCM)

AAC files

Compatible format	AAC encoded by iTunes
File extension	.m4a
Sampling frequency	11.025 kHz to 48 kHz
Stereo Bit Rate	16 kbps to 320 kbps, VBR
Apple Lossless	Not compatible
AAC file bought from the iTunes Store (.m4p file extension)	Not compatible

FLAC files

- FLAC file formats cannot be connected via MTP.
- FLAC files may not be playable, depending on the encoder.

File extension	.flac, .fla
Sampling frequency	8/11.025/12/16/22.05/24/32/44.1/48/96 kHz
Quantization bit rate	8/16/24 bit
Channel mode	1/2 ch

USB device

- There may be a slight delay when starting playback of audio files on a USB storage device with numerous folder hierarchies.

Playable folder hierarchy	Up to eight tiers (A practical hierarchy is less than two tiers.)
Playable folders	Up to 1 500
Playable files	Up to 15 000
Playback of copyright-protected files	Not compatible
Partitioned USB device	Only the first partition can be played.

iPhone compatibility

This unit supports only the following iPhone models. Older versions may not be supported.

Made for

- iPhone XR
- iPhone XS Max
- iPhone XS
- iPhone X
- iPhone 8
- iPhone 8 Plus
- iPhone 7
- iPhone 7 Plus
- iPhone SE
- iPhone 6s
- iPhone 6s Plus
- iPhone 6
- iPhone 6 Plus

- iPhone 5s

- Operations may vary depending on the generation and/or software version of the iPhone.
- Users of iPhone with the Lightning® Connector should use the Lightning to USB Cable (supplied with iPhone).
- Refer to the iPhone manuals for information about the file/format compatibility.
- Audiobook, Podcast: Compatible

⚠ CAUTION

Pioneer accepts no responsibility for data lost on the iPhone, even if that data is lost while this unit is used.

Sequence of audio files

The user cannot assign folder numbers and specify playback sequences with this unit. Sequence of audio file depends on the connected device.

Note that the hidden files in a USB device cannot be played back.

Example of a hierarchy

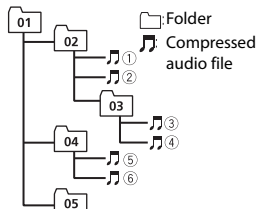

Level 1 Level 2 Level 3 Level 4

01 to 05: Folder number

① to ⑥: Playback sequence

Copyright and trademark

Bluetooth

The *Bluetooth*® word mark and logos are registered trademarks owned by Bluetooth SIG, Inc. and any use of such marks by PIONEER CORPORATION is under license. Other trademarks and trade names are those of their respective owners.

iTunes

Apple and iTunes are trademarks of Apple Inc., registered in the U.S. and other countries.

WMA

Windows Media is either a registered trademark or trademark of Microsoft Corporation in the United States and/or other countries.

This product includes technology owned by Microsoft Corporation and cannot be used or distributed without a license from Microsoft Licensing, Inc.

FLAC

Copyright © 2000-2009 Josh Coalson

Copyright © 2011-2014 Xiph.Org Foundation

Redistribution and use in source and binary forms, with or without modification, are permitted provided that the following conditions are met:

- Redistributions of source code must retain the above copyright notice, this list of conditions and the following disclaimer.
- Redistributions in binary form must reproduce the above copyright notice, this list of conditions and the following disclaimer in the documentation and/or other materials provided with the distribution.
- Neither the name of the Xiph.org Foundation nor the names of its contributors may be used to endorse or promote products derived from this

software without specific prior written permission.

THIS SOFTWARE IS PROVIDED BY THE COPYRIGHT HOLDERS AND CONTRIBUTORS "AS IS" AND ANY EXPRESS OR IMPLIED WARRANTIES, INCLUDING, BUT NOT LIMITED TO, THE IMPLIED WARRANTIES OF MERCHANTABILITY AND FITNESS FOR A PARTICULAR PURPOSE ARE DISCLAIMED. IN NO EVENT SHALL THE FOUNDATION OR CONTRIBUTORS BE LIABLE FOR ANY DIRECT, INDIRECT, INCIDENTAL, SPECIAL, EXEMPLARY, OR CONSEQUENTIAL DAMAGES (INCLUDING, BUT NOT LIMITED TO, PROCUREMENT OF SUBSTITUTE GOODS OR SERVICES; LOSS OF USE, DATA, OR PROFITS; OR BUSINESS INTERRUPTION) HOWEVER CAUSED AND ON ANY THEORY OF LIABILITY, WHETHER IN CONTRACT, STRICT LIABILITY, OR TORT (INCLUDING NEGLIGENCE OR OTHERWISE) ARISING IN ANY WAY OUT OF THE USE OF THIS SOFTWARE, EVEN IF ADVISED OF THE POSSIBILITY OF SUCH DAMAGE.

Pandora® Music

PANDORA, the PANDORA logo, and the Pandora trade dress are trademarks or registered trademarks of Pandora Media, LLC. Used with permission.

Pandora is only available in certain countries. Please visit <http://www.pandora.com/legal> for more information.

iPhone and Lightning

Use of the Made for Apple badge means that an accessory has been designed to connect specifically to the Apple product(s) identified in the badge, and has been certified by the developer to meet Apple performance standards. Apple is not responsible for the operation of this device or its compliance with safety and regulatory standards.

Please note that the use of this accessory with an Apple product may affect wireless performance.

iPhone and Lightning are trademarks of Apple Inc., registered in the U.S. and other countries.

Siri®

Works with Siri through the microphone.

Google™, Google Play, Android

Google, Google Play and Android are trademarks of Google LLC.

MIXTRAX

MIXTRAX is a trademark of the PIONEER CORPORATION.

Spotify®

SPOTIFY and the Spotify logo are among the registered trademarks of Spotify AB. Compatible mobile digital devices and premium subscription required, where available, see <https://www.spotify.com>.

T-Kernel 2.0

This product uses the source code of T-Kernel 2.0 under T-License 2.0 granted by T-Engine Forum (www.tron.org).

MP3

Copyright (C) 1998-2009 PacketVideo

Licensed under the Apache License, Version 2.0 (the "License"); you may not use this file except in compliance with the License.

You may obtain a copy of the License at

<http://www.apache.org/licenses/LICENSE-2.0>

Unless required by applicable law or agreed to in writing, software distributed under the License is distributed on an "AS IS" BASIS, WITHOUT WARRANTIES OR CONDITIONS OF ANY KIND, either express or implied.

See the License for the specific language governing permissions and limitations under the License.

Specifications

General

Power source: 14.4 V DC (10.8 V to 15.1 V allowable)

Grounding system: Negative type

Maximum current consumption: 10.0 A

Dimensions (W × H × D):

DIN

Chassis: 178 mm × 50 mm × 97 mm (7 in. × 2 in. × 3-7/8 in.)

Nose: 188 mm × 58 mm × 17 mm (7-3/8 in. × 2-1/4 in. × 5/8 in.)

D

Chassis: 178 mm × 50 mm × 97 mm (7 in. × 2 in. × 3-7/8 in.)

Nose: 170 mm × 46 mm × 17 mm (6-3/4 in. × 1-3/4 in. × 5/8 in.)

Weight: 0.5 kg (1.1 lbs)

Audio

Maximum power output:

- 50 W × 4 ch/4 Ω (for no subwoofer)
- 50 W × 2 ch/4 Ω + 70 W × 1 ch/2 Ω (for subwoofer)

Continuous power output:

22 W × 4 (50 Hz to 15 000 Hz, 5 % THD, 4 Ω load, both channels driven)

Load impedance: 4 Ω (4 Ω to 8 Ω (2 Ω for 1 ch) allowable)

Preout maximum output level: 2.0 V (MVH-S320BT), 4.0 V (MVH-S322BT)

Equalizer (13-Band Graphic Equalizer):

Frequency: 50 Hz/80 Hz/125 Hz/200 Hz/315 Hz/500 Hz/800 Hz/1.25 kHz/2 kHz/3.15 kHz/5 kHz/8 kHz/12.5 kHz
Gain: ±12 dB (2 dB step)

High pass filter:

Frequency: 25 Hz/31.5 Hz/40 Hz/50 Hz/63 Hz/80 Hz/100 Hz/125 Hz/160 Hz/200 Hz/250 Hz

Slope: -6 dB/oct, -12 dB/oct, -18 dB/oct, -24 dB/oct, OFF

Subwoofer/Low pass filter:

Frequency: 25 Hz/31.5 Hz/40 Hz/50 Hz/63 Hz/80 Hz/100 Hz/125 Hz/160 Hz/200 Hz/250 Hz

Slope: -6 dB/oct, -12 dB/oct, -18 dB/oct, -24 dB/oct, -30 dB/oct, -36 dB/oct, OFF

Phase: Normal/Reverse

Speaker level:

+10 dB to -24 dB (1 dB step)

Time alignment:

0 Inch to 140 Inch (1 inch/Step)

USB

USB standard specification: USB 2.0 full speed

Maximum current supply: 1.5 A

USB Protocol:

MSC (Mass Storage Class)

MTP (Media Transfer Protocol)

AOA (Android Open Accessory) 2.0

File system: FAT12, FAT16, FAT32

MP3 decoding format: MPEG-1 & 2 Audio Layer 3

WMA decoding format: Ver. 7, 8, 9, 9.1, 9.2 (2 ch audio)

AAC decoding format: MPEG-4 AAC (iTunes encoded only) (Ver. 10.6 and earlier)

FLAC decoding format: v1.2.1 (Free Lossless Audio Codec)

WAV signal format: Linear PCM (Non-compressed)

FM tuner

Frequency range: 87.9 MHz to 107.9 MHz

Usable sensitivity: 11 dBf (1.0 μ V/75 Ω , mono, S/N: 30 dB)

Signal-to-noise ratio: 65 dB (analog broadcasting) (IHF-A network)

AM tuner

Frequency range: 530 kHz to 1 710 kHz

Usable sensitivity: 25 μ V (S/N: 20 dB)

Signal-to-noise ratio: 60 dB (analog broadcasting) (IHF-A network)

Bluetooth

Version: Bluetooth 4.0 certified

Output power: +4 dBm Maximum (Power class 2)

BLE (Bluetooth Low Energy) Version: 4.0 certified

BLE (Bluetooth Low Energy) Output power: +3 dBm Maximum

Frequency band(s): 2 400 MHz to 2 483.5 MHz

Bluetooth profiles:

GAP (Generic Access Profile)

SDAP (Service Discovery Application Profile)

HFP (Hands Free Profile) 1.6

PBAP (Phone Book Access Profile)

A2DP (Advanced Audio Distribution Profile)

AVRCP (Audio/Video Remote Control Profile) 1.5

SPP (Serial Port Profile) 1.1

CTA2006 Specifications



Power output: 14 W RMS \times 4 Channels (4 Ω and \leq 1 % THD+N)

S/N ratio: 91 dBA (reference: 1 W into 4 Ω)

NOTE

Specifications and the design are subject to modifications without notice.

Visit our website / Visitez notre site Web / Visite nuestro sitio Web

Register your product at
Enregistrez votre produit au
Registre su producto en

<http://www.pioneerelectronics.com>

in Canada
au Canada <http://www.pioneerelectronics.ca>
en Canadá

-
- Learn about product updates (such as firmware updates) for your product.
 - Register your product to receive notices about product updates and to safeguard purchase details in our files in the event of loss or theft.
 - Access owner's manuals, spare parts information, service information, and much more.
-
- Informez-vous sur les mises à jour disponibles pour votre produit (telles que les mises à jour du firmware).
 - Enregistrez votre produit afin de recevoir des notifications concernant les mises à jour du produit, ainsi que pour sauvegarder les détails de votre achat dans nos fichiers en cas de perte ou de vol.
 - Accédez aux modes d'emploi, aux informations relatives aux pièces de rechange et à l'entretien, et à beaucoup d'autres informations.
-
- Infórmese de las últimas actualizaciones (por ejemplo, actualizaciones de firmware) para su producto.
 - Registre su producto para recibir información sobre actualizaciones del producto y para mantener la seguridad de los detalles de su compra en nuestros archivos en caso de pérdida o robo.
 - Acceso a manuales de instrucciones, información sobre piezas de recambio y mucho más.

PIONEER CORPORATION

28-8, Honkomagome 2-chome, Bunkyo-ku,
Tokyo 113-0021, Japan

PIONEER ELECTRONICS (USA) INC.

P.O. Box 1540, Long Beach, California 90801-1540, U.S.A.
TEL: (800) 421-1404

PIONEER EUROPE NV

Haven 1087, Keetberglaan 1, B-9120 Melsele, Belgium/Belgique
TEL: (0) 3/570.05.11

PIONEER ELECTRONICS ASIACENTRE PTE. LTD.

2 Jalan Kilang Barat, #07-01, Singapore 159346
TEL: 65-6378-7888

PIONEER ELECTRONICS AUSTRALIA PTY. LTD.

5 Arco Lane, Heatherton, Victoria, 3202 Australia
TEL: (03) 9586-6300

PIONEER ELECTRONICS DE MÉXICO S.A. DE C.V.

Bldv. Manuel Ávila Camacho 138, 10 piso
Col.Lomas de Chapultepec, México, D.F. 11000
Tel: 52-55-9178-4270, Fax: 52-55-5202-3714

先鋒股份有限公司

台北市內湖區瑞光路407號8樓
電話：886-(0) 2-2657-3588

先鋒電子(香港)有限公司

香港九龍長沙灣道909號5樓
電話：852-2848-6488

© 2019 PIONEER CORPORATION. All rights reserved.

© 2019 PIONEER CORPORATION. Tous droits de reproduction et de traduction réservés.

<OPM_MVHS320BTUC_3L_A> UC

Pioneer

DIGITAL MEDIA RECEIVER
RÉCEPTEUR NUMÉRIQUE MULTIMÉDIA
RECEPTOR DE MEDIOS DIGITALES

MVH-S322BT MVH-S320BT

Quick start guide Guide de démarrage rapide Guía de inicio rápido

Important (Serial number)

The serial number is located on the bottom of this unit. For your own security and convenience, be sure to record this number on the enclosed warranty card.

Important (Numéro de série)

Le numéro de série se trouve au bas de cet appareil. Pour votre sécurité et votre commodité, veuillez à noter ce numéro sur la carte de garantie fournie.

Importante (Número de serie)

El número de serie se encuentra en la parte inferior de esta unidad. Por su propia seguridad y comodidad, asegúrese de anotar este número en la tarjeta de garantía que se adjunta.

QRD3781-A

English

This guide is intended to guide you through the basic functions of this unit. For details, please refer to the Operation manual stored on the website.

<https://www.pioneerelectronics.com/PUSA/Support>

Before You Start

Thank you for purchasing this PIONEER product

To ensure proper use, please read through this guide before using this product. It is especially important that you read and observe **WARNINGS** and **CAUTIONS** in this guide. Please keep the guide in a safe and accessible place for future reference.

FCC ID: EW4C95

MODEL NO.: MVH-S322BT/MVH-S320BT

IC: 4250A-C95

This device contains licence-exempt transmitter(s)/receiver(s) that complies with Part 15 of FCC Rules and Innovation, Science, and Economic Development Canada licence-exempt RSS(s). Operation is subject to the following two conditions: (1) this device may not cause interference, and (2) this device must accept any interference, including interference that may cause undesired operation of this device.

This transmitter must not be co-located or operated in conjunction with any other antenna or transmitter.

The Bluetooth antenna cannot be removed (or replaced) by user.

This equipment complies with FCC/ISED radiation exposure limits set forth for an uncontrolled environment and meets the FCC radio frequency (RF) Exposure Guidelines and RSS-102 of the ISED radio frequency (RF) Exposure rules. This equipment has very low levels of RF energy that it deemed to comply without maximum permissive exposure evaluation (MPE). But it is desirable that it should be installed and operated keeping the radiator at least 20cm or more away from person's body (excluding extremities: hands, wrists, feet and ankles).

Alteration or modifications carried out without appropriate authorization may invalidate the user's right to operate the equipment.

Installation

Important

- Check all connections and systems before final installation.
- Do not use unauthorized parts as this may cause malfunctions.
- Consult your dealer if installation requires drilling of holes or other modifications to the vehicle.
- Do not install this unit where:
 - it may interfere with operation of the vehicle.
 - it may cause injury to a passenger as a result of a sudden stop.
- Install this unit away from hot places such as near the heater outlet.
- Optimum performance is obtained when the unit is installed at an angle of less than 60°.
- When installing, to ensure proper heat dispersal when using this unit, make sure you leave ample space behind the rear panel and wrap any loose cables so they are not blocking the vents.

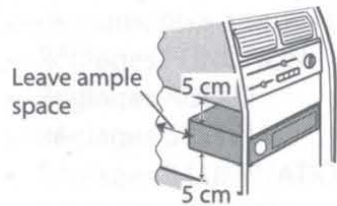
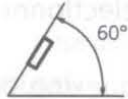

DIN mount installation

- 1 Insert the supplied mounting sleeve into the dashboard.
- 2 Secure the mounting sleeve by using a screwdriver to bend the metal tabs (90°) into place.

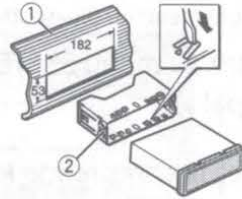

- ① Dashboard
- ② Mounting sleeve

- Make sure that the unit is installed securely in place. An unstable installation may cause skipping or other malfunctions.

When not using the supplied mounting sleeve

- 1 Line up the holes on the mounting bracket with the holes on the sides of the unit to attach the bracket.

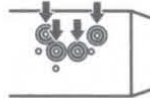

- 2 Screw in one screw on each side to hold the unit in place.

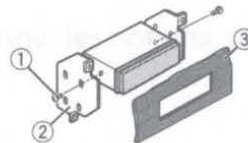

- ① Screw
- ② Mounting bracket
- ③ Dashboard or console

- Use either truss (5 mm × 9 mm) or flush surface (5 mm × 9 mm) screws, depending on the bracket screw holes.

Using the included bracket

Check to make sure that the included bracket matches your particular model of vehicle and then attach it to the unit as shown below.

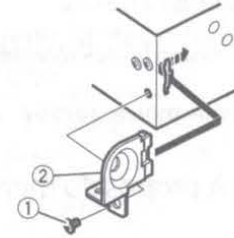
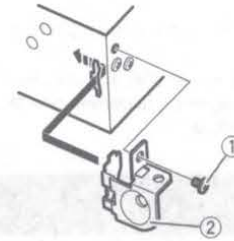

- ① Screw
- ② Bracket

Removing the unit (installed with the supplied mounting sleeve)

- 1 Remove the trim ring.

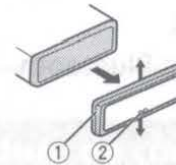

- ① Trim ring
- ② Notched tab

- Releasing the front panel allows easier access to the trim ring.
- When reattaching the trim ring, point the side with the notched tab down.

- 2 Insert the supplied extraction keys into both sides of the unit until they click into place.
- 3 Pull the unit out of the dashboard.

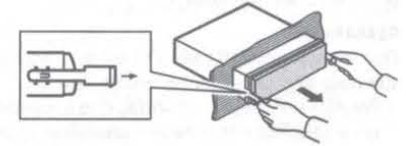

To secure the front panel

The front panel can be secured with the supplied screw.

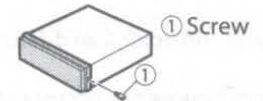

Basic operation

MVH-S322BT/S320BT

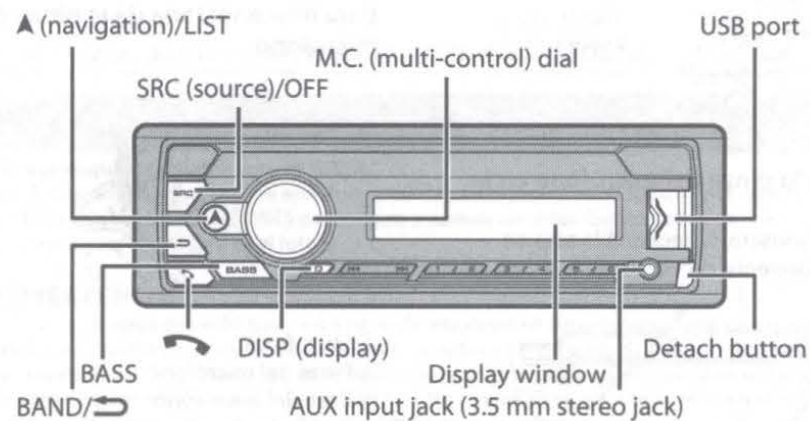

About the main menu

You can adjust various settings in the main menu.

- 1 Press the **M.C.** dial to display the main menu.
- 2 Turn the **M.C.** dial to select one of the categories below, then press to confirm.
 - FUNCTION settings
 - AUDIO settings
 - SYSTEM settings
 - ILLUMINATION settings
 - MIXTRAX settings
- 3 Turn the **M.C.** dial to select the options, then press to confirm.

Making a connection with Pioneer Smart Sync

Pioneer Smart Sync is the application that intelligently brings your maps, messages, and music together in the vehicle.



Download Now

Pioneer Smart Sync



⚠ WARNING

Do not attempt to operate the application while driving. Make sure to pull off the road and park your vehicle in a safe location before attempting to use the controls on the application.

- 1 Enter the SYSTEM menu (refer to “About the main menu”).
- 2 Turn the **M.C.** dial to select [APP CONTROL], then press to confirm.
- 3 Turn the **M.C.** dial to select one of the below.
 - Select [WIRED] for the USB connection.
 - Select [BLUETOOTH] for the Bluetooth connection.
- 4 Turn the **M.C.** dial to select [AUTO APP CONN], then press to confirm.
- 5 Turn the **M.C.** dial to select [ON], then press to confirm.
- 6 Connect this unit with the mobile device via USB or Bluetooth. Pioneer Smart Sync on the iPhone/Android device starts automatically.

NOTE

Regardless of whether the [AUTO APP CONN] setting is set to [ON] or [OFF], you can also perform the following to start Pioneer Smart Sync.

- For devices other than the USB-connected Android device, press **SRC/OFF** to select any source and press and hold the **M.C.** dial.
- For iPhone, launch Pioneer Smart Sync on the mobile device.

Listening to Pandora®

(Not available when [USB MTP] is set to [ON] in the SYSTEM settings.)

Update the firmware of the Pandora application to the latest version before use. Before you start, connect this unit with the mobile device via USB (iPhone only) or Bluetooth.

- 1 Enter the SYSTEM menu (refer to “About the main menu”).
- 2 Turn the **M.C.** dial to select [APP CONTROL], then press to confirm.
- 3 Turn the **M.C.** dial to select one of the below.
 - Select [WIRED] for the USB connection.
 - Select [BLUETOOTH] for the Bluetooth connection.
- 4 Press **SRC/OFF** to select [PANDORA].
- 5 Launch the Pandora application on the mobile device and start playback.

Funcionamiento de la configuración

Una vez de la instalación, que la lista de configuración de la unidad de sonido y vídeo se muestra en la pantalla.

- 1 Gire el dial M.C. para seleccionar [LANGUAGE] y luego presione el dial para confirmar.
[ENG] ↔ [ESP] ↔ [FRA]
- 2 Gire el dial M.C. para seleccionar [CLOCK SET] y luego presione el dial para confirmar.
1 Gire el dial M.C. para ajustar la hora y presione para confirmar.
El indicador se mueve al ajuste de minutos automáticamente.

Note

This equipment has been tested and found to comply with the limits for a Class B digital device, pursuant to Part 15 of the FCC Rules. These limits are designed to provide reasonable protection against harmful interference in a residential installation. This equipment generates, uses and can radiate radio frequency energy and, if not installed and used in accordance with the instructions, may cause harmful interference to radio communications. However, there is no guarantee that interference will not occur in a particular installation. If this equipment does cause harmful interference to radio or television reception, which can be determined by turning the equipment off and on, the user is encouraged to try to correct the interference by one or more of the following measures:

- Reorient or relocate the receiving antenna.
- Increase the separation between the equipment and receiver.
- Connect the equipment into an outlet on a circuit different from that to which the receiver is connected.
- Consult the dealer or an experienced radio/TV technician for help.

FEDERAL COMMUNICATIONS COMMISSION SUPPLIER'S DECLARATION OF CONFORMITY

Product Name: DIGITAL MEDIA RECEIVER
Model Number: MVH-S322BT/MVH-S320BT
Responsible Party Name: PIONEER ELECTRONICS (USA), INC. SERVICE SUPPORT DIVISION
Address: 2050 W. 190TH STREET, SUITE 100, TORRANCE, CA 90504, U.S.A.
Phone: 1-800-421-1404
URL: <http://www.pioneerelectronics.com>

The Safety of Your Ears is in Your Hands

Get the most out of your equipment by playing it at a safe level—a level that lets the sound come through clearly without annoying blaring or distortion and, most importantly, without affecting your sensitive hearing. Sound can be deceiving.

Over time, your hearing "comfort level" adapts to higher volumes of sound, so what sounds "normal" can actually be loud and harmful to your hearing. Guard against this by setting your equipment at a safe level BEFORE your hearing adapts.

ESTABLISH A SAFE LEVEL:

- Set your volume control at a low setting.
- Slowly increase the sound until you can hear it comfortably and clearly, without distortion.
- Once you have established a comfortable sound level, set the dial and leave it there.

BE SURE TO OBSERVE THE FOLLOWING GUIDELINES:

- Do not turn up the volume so high that you can't hear what's around you.
- Use caution or temporarily discontinue use in potentially hazardous situations.
- Do not use headphones while operating a motorized vehicle; the use of headphones may create a traffic hazard and is illegal in many areas.

⚠ WARNING

- Rear visibility systems (backup cameras) are required in certain new vehicles sold in the U.S. and Canada. U.S. regulations began according to a two year phase-in on May 1, 2016, and both the U.S. and Canada require that all such vehicles manufactured on or after May 1, 2018 have rear visibility systems. **Owners of vehicles equipped with compliant rear visibility systems should not install or use this product in a way that alters or disables that system.** If you are unsure whether your vehicle has a rear visibility system subject to the U.S. or Canadian regulations, please contact the vehicle manufacturer or dealer.
- **Do not attempt to install or service this product by yourself. Installation or servicing of this product by persons without training and experience in electronic equipment and automotive accessories may be dangerous and could expose you to the risk of electric shock, injury or other hazards.**
- Do not attempt to operate the unit while driving. Make sure to pull off the road and park your vehicle in a safe location before attempting to use the controls on the device.
- This product contains chemicals known to the State of California and other governmental entities to cause cancer and birth defects or other reproductive harm. **Wash hands after handling.**

⚠ CAUTION

- Do not allow this unit to come into contact with moisture and/or liquids. Electrical shock could result. Also, damage to this unit, smoke, and overheating could result from contact with liquids.
- Always keep the volume low enough to hear outside sounds.
- This product is evaluated in moderate and tropical climate condition under the Audio, video and similar electronic apparatus - Safety requirements, IEC 60065.

After-sales service for Pioneer products

Please contact the dealer, distributor from where you purchased this unit or the authorized PIONEER Service Station for after-sales service or any other information. In case the necessary information is not available, please contact the companies listed below:

Please do not ship your unit to the companies at the addresses listed below for repair without contacting them in advance.

U.S.A. and CANADA

Pioneer Electronics (USA) Inc.
CUSTOMER SUPPORT DIVISION
P.O. Box 1760
Long Beach, CA 90801-1760
800-421-1404

For warranty information please see the Limited Warranty sheet included with this unit.

Installing the microphone

The microphone should be placed directly in front of the driver at a suitable distance to pick up their voice clearly.

CAUTION

It is extremely dangerous to allow the microphone lead to become wound around the steering column or shift lever. Be sure to install the microphone in such a way that it will not obstruct driving. It is recommended to use the clamps (sold separately) to arrange the lead.

NOTE

Depending on the vehicle model, the microphone cable length may be too short when you mount the microphone on the sun visor. In such cases, install the microphone on the steering column.

To install on the sun visor

- 1 Fit the microphone lead into the groove.



- 2 Install the microphone clip on the sun visor.

Lowering the sun visor reduces the voice recognition rate.

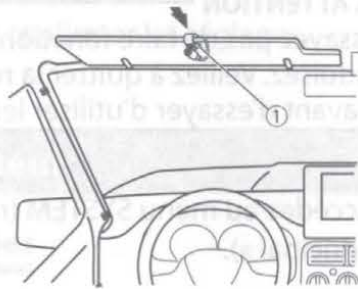

To install on the steering column

- 1 Slide the microphone base to detach it from the microphone clip.

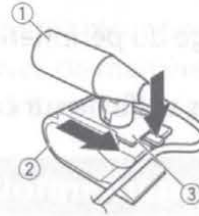

- 2 Install the microphone on the rear side of the steering column.

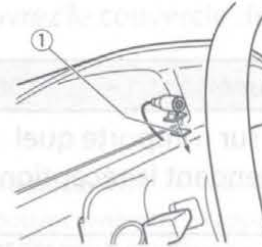

Frequently used operations

Purpose	Operation
Turn on the power	Press SRC/OFF to turn on the power. Press and hold SRC/OFF to turn off the power.
Adjust the volume	Turn the M.C. dial.
Select a source	Press SRC/OFF repeatedly.
Change the display information	Press DISP repeatedly.
Return to the previous display/list	Press BAND/↵ .
Return to the normal display from the menu	Press and hold BAND/↵ .
Change the display brightness	Press and hold BAND/↵ .
Boost the bass level	Press BASS . • You can select the bass level ([HI] or [LOW]) in [D.BASS].

Setup operation

When you turn the ignition switch to ON after installation, the setup menu appears in the display.

- Turn the **M.C.** dial to select [LANGUAGE], then press to confirm.
[ENG] ↔ [ESP] ↔ [FRA]
- Turn the **M.C.** dial to select [CLOCK SET], then press to confirm.
 - Turn the **M.C.** dial to adjust the hour, then press to confirm.
The indicator moves to the minute setting automatically.
 - Turn the **M.C.** dial to adjust the minute, then press to confirm.
- [QUIT :YES] appears.
To return to the first item of the setup menu, turn the **M.C.** dial to select [QUIT :NO], then press to confirm.
- Press the **M.C.** dial to confirm the settings.



Listening to Spotify®

(Not available when [USB MTP] is set to [ON] in the SYSTEM settings.)

Update the firmware of the Spotify application to the latest version before use.
Before you start, connect this unit with the mobile device via USB (iPhone only) or Bluetooth.

- 1 Enter the SYSTEM menu (refer to "About the main menu").
- 2 Turn the **M.C.** dial to select [APP CONTROL], then press to confirm.
- 3 Turn the **M.C.** dial to select one of the below.
 - Select [WIRED] for the USB connection.
 - Select [BLUETOOTH] for the Bluetooth connection.
- 4 Press **SRC/OFF** to select [SPOTIFY].
- 5 Launch the Spotify application on the mobile device and start playback.

Bluetooth

- 1 Active la función Bluetooth del dispositivo.
- 2 Seleccione el nombre de la unidad que aparece en la pantalla del dispositivo.
- 3 Asegúrese de que el teléfono móvil y la unidad estén conectados al mismo Bluetooth.
- 4 Seleccione [YES] en la pantalla del dispositivo.

Telefono Bluetooth

Objetivo	Funcionamiento físico
Responder una llamada entrante	Presionar el botón de llamada
Colgar una llamada entrante	Presionar el botón de llamada
Responder una llamada saliente	Presionar el botón de llamada
Colgar una llamada saliente	Presionar el botón de llamada

- 1 Mantenga presionado el botón de llamada en el teléfono móvil para activar el modo de reconexión automática.

Connections

⚠ WARNING

- When speaker output is used by 4 channels, use speakers rated over 50 W (maximum input power) and between 4 Ω to 8 Ω (impedance value). Do not use 1 Ω to 3 Ω speakers for this unit.
- When rear speaker output is used by a 2 Ω subwoofer, use speakers rated for over 70 W.
- Please refer to connections for a connection method.
- The black cable is ground. When installing this unit or power amp (sold separately), make sure to connect the ground wire first. Ensure that the ground wire is properly connected to metal parts of the car's body. The ground wire of the power amp and the one of this unit or any other device must be connected to the car separately with different screws. If the screw for the ground wire loosens or falls out, it could result in fire, generation of smoke or malfunction.

Two devices connected to the car separately (ground wires)

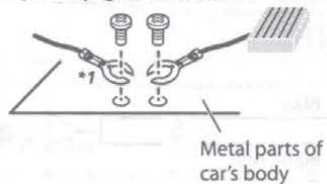

*1 Not supplied for this unit

🔌 Important

- When installing this unit in a vehicle without an ACC (accessory) position on the ignition switch, failure to connect the red cable to the terminal that detects operation of the ignition key may result in battery drain.



ACC position



No ACC position

- Use this unit with a 12-volt battery and negative grounding only. Failure to do so may result in a fire or malfunction.
- To prevent a short-circuit, overheating or malfunction, be sure to follow the directions below.
 - Disconnect the negative terminal of the battery before installation.
 - Secure the wiring with cable clamps or adhesive tape. Wrap adhesive tape around wiring that comes into contact with metal parts to protect the wiring.
 - Place all cables away from moving parts, such as the shift lever and seat rails.
 - Place all cables away from hot places, such as near the heater outlet.
 - Do not connect the yellow cable to the battery by passing it through the hole to the engine compartment.
 - Cover any disconnected cable connectors with insulating tape.
 - Do not shorten any cables.
 - Never cut the insulation of the power cable of this unit in order to share the power with other devices. The current capacity of the cable is limited.
 - Use a fuse of the rating prescribed.
 - Never wire the negative speaker cable directly to ground.
 - Never band together negative cables of multiple speakers.

- When this unit is on, control signals are sent through the blue/white cable. Connect this cable to the system remote control of an external power amp or the vehicle's auto-antenna relay control terminal (max. 300 mA 12 V DC). If the vehicle is equipped with a glass antenna, connect it to the antenna booster power supply terminal.
- Never connect the blue/white cable to the power terminal of an external power amp. Also, never connect it to the power terminal of the auto antenna. Doing so may result in battery drain or a malfunction.
- The graphical symbol  placed on the product means direct current.

This unit

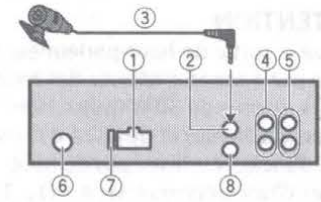

- ① Power cord input
 - ② Microphone input
 - ③ Microphone 3 m (9 ft. 10-1/8 in.)
 - ④ Rear output or subwoofer output
 - ⑤ Front output
 - ⑥ Antenna input
 - ⑦ Fuse (10 A)
 - ⑧ Wired remote input
- Hard-wired remote control adapter can be connected (sold separately).

Power cord

Perform these connections when not connecting a rear speaker lead to a subwoofer.

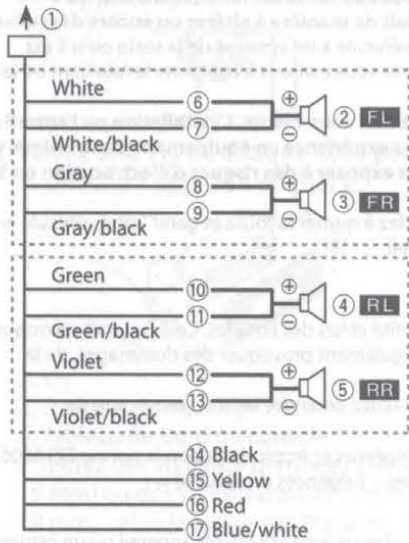

Perform these connections when using a subwoofer without the optional amplifier.

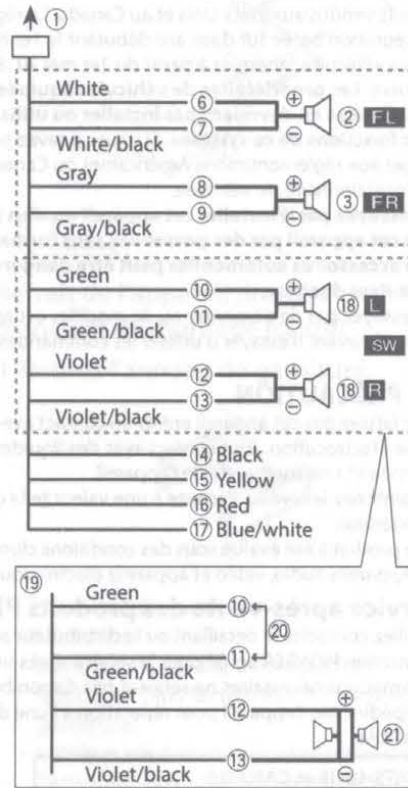

Important

In the case of ⑱ above, two 4 Ω subwoofers wired in parallel will represent a 2 Ω load.

- ① To power cord input
- ② Front left speaker
- ③ Front right speaker
- ④ Rear left speaker
- ⑤ Rear right speaker
- ⑥ White
- ⑦ White/black
- ⑧ Gray
- ⑨ Gray/black
- ⑩ Green
- ⑪ Green/black
- ⑫ Violet
- ⑬ Violet/black
- ⑭ Black (chassis ground)
Connect to a clean, paint-free metal location.
- ⑮ Yellow
Connect to the constant 12 V supply terminal.
- ⑯ Red
Connect to terminal controlled by the ignition switch (12 V DC).
- ⑰ Blue/white
Connect to the system control terminal of the power amp or auto-antenna relay control terminal (max. 300 mA 12 V DC).
- ⑱ Subwoofer (4 Ω)
- ⑲ When using a subwoofer of 2 Ω, be sure to connect the subwoofer to the violet and violet/black leads of this unit. Do not connect anything to the green and green/black leads.
- ⑳ Not used.
- ㉑ Subwoofer (4 Ω) × 2

Power amp (sold separately)

Perform these connections when using the optional amplifier.

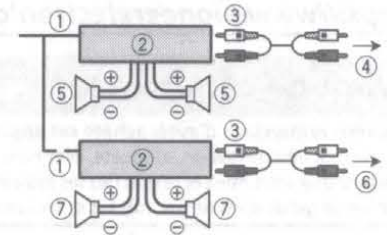

- ① System remote control
Connect to blue/white cable.
- ② Power amp (sold separately)
- ③ Connect with RCA cables (sold separately)
- ④ To front output
- ⑤ Front speaker
- ⑥ To rear output or subwoofer output
- ⑦ Rear speaker or subwoofer

Tuner operation

Receiving preset stations

- 1 Press **SRC/OFF** to select [RADIO].
- 2 Press **BAND/↔** to select the band.
[FM1] ↔ [FM2] ↔ [FM3] ↔ [AM]
- 3 Press a number button (1/∧ to 6/⇨).

Best stations memory (BSM)

- 1 After selecting the band, press the **M.C.** dial to display the main menu.
- 2 Turn the **M.C.** dial to select [FUNCTION], then press to confirm.
- 3 Turn the **M.C.** dial to select [BSM], then press to confirm.

To store stations manually

- 1 While receiving the station you want to store, press and hold one of the number buttons (1/∧ to 6/⇨) until it stops flashing.

USB/iPhone®/AUX operation

(iPhone source is not available when [USB MTP] is set to [ON] in the SYSTEM settings.)

USB/iPhone

- 1 Open the USB port cover.
- 2 Plug in the USB device/iPhone using an appropriate cable.

MTP connection

A device installed with Android OS 4.0 or most of later versions can be connected to the unit via MTP, using the cable supplied with the device. However, depending on the connected device, OS version or the numbers of the files in the device, audio files/songs may not be able to be played back via MTP.

NOTE

If you use an MTP connection, [USB MTP] needs to be set to [ON] in the SYSTEM settings.

AUX

- 1 Insert the stereo mini plug into the AUX input jack.
- 2 Press **SRC/OFF** to select [AUX IN] as the source.





Bluetooth connection

Up to two Bluetooth telephones can be connected simultaneously.

- 1 Turn on the Bluetooth function of the device.
- 2 Select the unit name shown in the device display.
- 3 Make sure the same 6-digit number appears on this unit and the device.
- 4 Select [YES].

Bluetooth telephone

Basic operations

Purpose	Operation
Answer an incoming call	Press any button when a call is received.
End a call	Press  .
Reject an incoming call	Press and hold  when a call is received.

Activating voice recognition mode

- 1 Press and hold  and then talk into the microphone to input voice commands.

To exit the voice recognition mode, press **BAND/** .

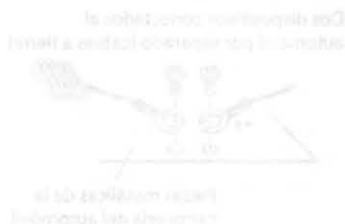

Operaciones frecuentes

Operaciones frecuentes



PIONEER ELECTRONICS (USA) INC.
LIMITED WARRANTY

WARRANTY VALID ONLY IN COUNTRY OF PRODUCT PURCHASE

WARRANTY

Pioneer Electronics (USA) Inc. (Pioneer) warrants that Pioneer® Car Electronics, Speaker, and Accessory Products distributed by Pioneer in the U.S.A. and Canada that fail to function properly under normal use due to a manufacturing defect when installed and operated according to the owner's manual enclosed with the unit will be repaired or replaced with a unit of comparable value, at Pioneer's option, without charge to you for parts or actual repair work. Replacement units and/or parts supplied under this warranty may be new or rebuilt at Pioneer's option.

This Limited Warranty applies to the original or any subsequent owner of this Pioneer product during the warranty period provided the product was purchased from an authorized Pioneer dealer in the U.S.A. or Canada. You will be required to provide a sales receipt or other valid proof of purchase showing the date of original purchase. In the event service is required, the product must be delivered within the warranty period, transportation prepaid, only from within the country of purchase as explained in this document. You will be responsible for removal and installation of the product. Pioneer will pay to return the repaired or replacement product to you within the country of purchase.

PRODUCT WARRANTY PERIOD (Runs from the date of first retail sale)

	<u>Parts</u>	<u>Labor</u>
Car Electronics, Speakers, and Accessories	1 Year	1 Year

WHAT IS NOT COVERED

This Limited Warranty applies to Pioneer products that are purchased from an authorized Pioneer dealer. IF THIS PRODUCT WAS PURCHASED FROM ANY OTHER SOURCE, THERE ARE NO WARRANTIES, EXPRESS OR IMPLIED, INCLUDING THE IMPLIED WARRANTY OF MERCHANTABILITY AND THE IMPLIED WARRANTY OF FITNESS FOR A PARTICULAR PURPOSE AND THIS PRODUCT IS SOLD STRICTLY "AS IS" AND "WITH ALL FAULTS". PIONEER SHALL NOT BE LIABLE FOR ANY CONSEQUENTIAL AND/OR INCIDENTAL DAMAGES. Some states and provinces do not allow the exclusion or limitation of incidental or consequential damages, so the above limitation or exclusion may not apply to you.

Pioneer does not warrant any product listed above when it is used in a trade or business or in any industrial or commercial application. This warranty does not apply if the product has been subjected to power in excess of its published power rating. This warranty does not cover cosmetic scratches or any other appearance item; damage or defects resulting from alterations or modifications not authorized in writing by Pioneer; accident, collisions, misuse or abuse; the use of unauthorized parts or labor; improper installation or maintenance; lightning or power surges; subsequent damage from leaking; damage from inoperative batteries; or the use of batteries not conforming to those specified in the owner's manual. This warranty does not cover the cost of parts or labor that would otherwise be provided without charge under this warranty obtained from any source other than Pioneer. Altered, defaced, or removed serial numbers void this warranty.

NO OTHER WARRANTIES

TO THE FULLEST EXTENT PERMITTED BY LAW, PIONEER MAKES NO REPRESENTATIONS OR WARRANTIES OR ACCEPTS ANY CONDITIONS WITH RESPECT TO THIS PRODUCT EXCEPT AS STATED IN THIS DOCUMENT. PIONEER LIMITS ITS OBLIGATIONS UNDER ANY IMPLIED WARRANTIES AND CONDITIONS INCLUDING, BUT NOT LIMITED TO, WARRANTIES AND CONDITIONS, WHETHER EXPRESS OR IMPLIED, OF MERCHANTABILITY AND FITNESS FOR A PARTICULAR PURPOSE, TO A PERIOD NOT TO EXCEED THE WARRANTY PERIOD. NO WARRANTIES OR CONDITIONS SHALL APPLY AFTER THE WARRANTY PERIOD. Some states and provinces do not allow limitations on how long an implied warranty lasts, so the above limitations or exclusions may not apply to you.

This warranty gives you specific legal rights, and you may also have other rights which vary from state to state or province to province. To the extent any provision of this limited warranty is deemed invalid or unenforceable under applicable law, such determination will have no effect on the remaining provisions, which will continue in full force and effect.

TO OBTAIN SERVICE

In the U.S.A. or Canada, to receive warranty service, you need to present your sales receipt showing place and date of original owner's transaction.

Please contact one of the following to obtain service:

Your Authorized Pioneer Dealer - Your Pioneer Dealer may repair or replace your unit or refer you to an Authorized Pioneer Service Company. Your sales receipt should list the contact information (phone number, fax, email, etc.) for your Dealer.

Pioneer Customer Support - Can advise the optimal service option for your model and geographic location. Please call us at 1-800-421-1404 or visit www.pioneerelectronics.com (for USA) or <http://www.pioneerelectronics.ca> (for Canada), click on "Support," then select "Contact Us."

Your Authorized Pioneer Service Company - Can perform repairs for most Car Electronics, Speaker and Accessory products and advise other options as applicable. Please visit Pioneer's website, click on "Support," and select "Find a Service Center."

Shipping Your Unit for Service - YOU MUST FIRST CONTACT PIONEER TO GET RETURN AUTHORIZATION. PLEASE DO NOT SEND IN YOUR PRODUCT WITHOUT CONTACTING CUSTOMER SUPPORT. If you have a return authorization number, please package the product carefully and send it transportation prepaid by a traceable, insured method to an Authorized Pioneer Service Company or Pioneer. Use adequate padding material to prevent damage in transit. Include your name, address and a telephone number where you can be reached during business hours.

For questions about your product, please contact Pioneer Customer Support as described above or write to us at:

Customer Support
Pioneer Electronics (USA) Inc.
P.O. Box 1720
Long Beach, California 90801 U.S.A.

DISPUTE RESOLUTION

Following our response to any initial request to Customer Support, should a dispute arise between you and Pioneer, Pioneer makes available its Complaint Resolution Program to resolve the dispute. The Complaint Resolution Program is available to you without charge. In the U.S.A., you are required to use the Complaint Resolution Program before you exercise any rights under, or seek any remedies, created by the Magnuson-Moss Warranty Act but may be entitled to file suit under state law without using the Complaint Resolution Program. To use the Complaint Resolution Program, call 1-800-421-1404 and explain to the customer service representative the problem you are experiencing, steps you have taken to have the product repaired during the warranty period, and the name of the authorized Pioneer Dealer from which the Pioneer product was purchased. After the complaint has been explained to the representative, a resolution number will be issued. Within forty (40) days of receiving your complaint, Pioneer will investigate the dispute and will either: (1) respond to your complaint in writing informing you what action Pioneer will take, and in what time period, to resolve the dispute; or (2) respond to your complaint in writing informing you why Pioneer will not take any action.

RECORD THE PLACE AND DATE OF PURCHASE. KEEP THIS INFORMATION AND YOUR SALES RECEIPT IN A SAFE PLACE

Model No. _____ Serial No. _____ Purchase Date _____

Purchased From _____



PIONEER ELECTRONICS (USA) INC.

GARANTIE LIMITÉE

GARANTIE VALIDE UNIQUEMENT DANS LE PAYS D'ACHAT DU PRODUIT

GARANTIE

Pioneer Electronics (USA) Inc. (ci-après « Pioneer ») garantit que les appareils électroniques, haut-parleurs et produits accessoires automobiles Pioneer® distribués par Pioneer aux États-Unis et au Canada, s'ils sont installés et utilisés conformément au manuel de l'utilisateur qui accompagne l'appareil et ne fonctionnent pas correctement dans des conditions normales d'utilisation en raison d'un défaut de fabrication, seront réparés ou remplacés par un appareil de valeur comparable, à la discrétion de Pioneer, sans frais de pièces ou de réparation. Les appareils de remplacement et/ou pièces fournies en vertu de cette garantie peuvent être neufs ou remis à neuf, à la discrétion de Pioneer.

Cette garantie limitée s'applique au propriétaire initial ou à tout propriétaire ultérieur de ce produit Pioneer pendant la période de garantie, sous réserve que le produit ait été acheté d'un détaillant Pioneer autorisé aux États-Unis ou au Canada. Vous devrez fournir un reçu de caisse ou autre preuve d'achat valide indiquant la date de l'achat initial. Si une réparation s'avère nécessaire, le produit doit être expédié dans la période de garantie, frais de port prépayés, uniquement depuis le pays de l'achat, et tel qu'expliqué dans le présent document. Vous serez responsable du retrait et de l'installation du produit. Pioneer paiera les frais de retour du produit réparé ou de remplacement, à l'intérieur du pays d'achat.

PÉRIODE DE GARANTIE DU PRODUIT (La garantie prend effet à compter de la première vente au détail)

Pièces Main-d'œuvre

Appareils électroniques, haut-parleurs et produits accessoires automobiles 1 an 1 an

ÉLÉMENTS NON COUVERTS PAR LA GARANTIE

Cette garantie limitée s'applique aux produits Pioneer achetés d'un détaillant Pioneer autorisé. SI CE PRODUIT A ÉTÉ ACHETÉ DE TOUTE AUTRE SOURCE, IL N'Y A PAS DE GARANTIES, EXPLICITES OU IMPLICITES, Y COMPRIS LES GARANTIES IMPLICITES DE QUALITÉ MARCHANDE ET GARANTIES IMPLICITES D'ADAPTATION À UN USAGE PARTICULIER, ET CE PRODUIT EST VENDU « TEL QUEL » ET « AVEC TOUS SES DÉFAUTS ». PIONEER NE SERA RESPONSABLE D'AUCUN DOMMAGE CONSÉCUTIF ET/OU ACCESSOIRE. Certains États et certaines provinces n'autorisent pas l'exclusion ou la limitation des dommages consécutifs ou indirects, par conséquent, la limitation ou l'exclusion indiquée plus haut peut ne pas s'appliquer à vous.

Pioneer ne garantit aucun des produits énumérés ci-dessus s'ils sont utilisés à des fins commerciales ou professionnelles, ou dans toute application industrielle ou commerciale. Cette garantie ne s'applique pas si le produit a été soumis à une puissance nominale excédant celle indiquée dans les documents s'y appliquant. Cette garantie ne couvre pas les rayures ou tout autre élément esthétique ; les dommages ou défauts résultant de retouches ou modifications non autorisées par écrit par Pioneer ; les accidents, collisions, usages inappropriés ou abusifs ; l'utilisation non autorisée de pièces ou de main-d'œuvre ; l'installation ou la maintenance inadéquate ; les dommages causés par la foudre ou la surtension ; les dommages découlant de fuites ; les dommages découlant de piles défectueuses ; ou l'utilisation de piles non conformes à celles spécifiées dans le manuel de l'utilisateur. Cette garantie ne couvre pas le coût des pièces ou de la main-d'œuvre qui seraient autrement offertes sans frais en vertu de la présente garantie, si elles sont obtenues auprès d'une source autre que Pioneer. Les numéros de série modifiés, oblitérés ou enlevés annulent cette garantie.

INVALIDITÉ DE TOUTES AUTRES GARANTIES

DANS TOUTE LA MESURE AUTORISÉE PAR LA LOI, SAUF DISPOSITION CONTRAIRE DANS LE PRÉSENT DOCUMENT, PIONEER NE FAIT AUCUNE REPRÉSENTATION ET N'OFFRE AUCUNE GARANTIE, NI N'ACCEPTE AUCUNE CONDITION CONCERNANT CE PRODUIT. PIONEER LIMITE SES OBLIGATIONS EN VERTU DE TOUTES GARANTIES ET CONDITIONS IMPLICITES, Y COMPRIS, MAIS SANS S'Y LIMITER, LES GARANTIES ET CONDITIONS, EXPRESSES OU IMPLICITES, DE COMMERCIALITÉ ET D'ADAPTATION À UN USAGE PARTICULIER, À UNE PÉRIODE N'EXCÉDANT PAS LA PÉRIODE DE GARANTIE. AUCUNE GARANTIE OU CONDITION NE S'APPLIQUERA APRÈS LA PÉRIODE DE GARANTIE. Certains états et certaines provinces n'autorisent pas les limitations sur la durée d'une garantie implicite. Par conséquent, il se pourrait que certaines des limitations ou exclusions précitées ne s'appliquent pas à vous.

Cette garantie vous confère des droits spécifiques légaux, mais vous pouvez bénéficier d'autres droits qui peuvent varier selon les États ou les provinces. Dans la mesure où toute disposition de cette garantie limitée est considérée comme invalide ou inexécutable en vertu du droit applicable, elle sera sans effet sur les autres dispositions, qui resteront pleinement en vigueur.

DEMANDE DE SERVICE

Aux États-Unis et au Canada, pour recevoir un service de garantie vous devez présenter votre reçu de caisse indiquant le lieu et la date de la transaction d'origine.

Pour toute demande de service, veuillez contacter :

Votre détaillant Pioneer autorisé - Votre détaillant Pioneer peut réparer ou remplacer votre appareil ou vous mettre en contact avec une entreprise de services Pioneer autorisée. Vous devriez trouver les coordonnées (numéro de téléphone, numéro de télécopieur, adresse de courriel, etc.) de votre détaillant sur votre reçu de caisse.

Support à la clientèle Pioneer - peut vous conseiller sur le choix de l'option de service optimal pour votre modèle et votre région géographique. Appelez-nous au **1-800-421-1404** ou visitez notre site Web à www.pioneerelectronics.com (pour les États-Unis) ou <http://www.pioneerelectronics.ca> (pour le Canada), cliquez sur « Soutien », puis sélectionnez « Contactez-nous ».

Votre entreprise de services Pioneer autorisée - peut effectuer des réparations pour la plupart des produits électroniques automobiles, des haut-parleurs et des produits accessoires et peut vous conseiller sur le choix d'autres options, selon le cas. Visitez le site Web de Pioneer, cliquez sur « Soutien », puis sélectionnez « Trouver un Centre de service ».

Expédition de votre appareil aux fins de service — VOUS DEVEZ D'ABORD CONTACTER PIONEER POUR OBTENIR UNE AUTORISATION DE RETOUR. VEUILLEZ NE PAS ENVOYER VOTRE PRODUIT SANS AVOIR D'ABORD CONTACTÉ LE SERVICE À LA CLIENTÈLE. Si vous avez un numéro d'autorisation de retour, veuillez emballer le produit soigneusement et l'envoyer, frais de port prépayés avec un service d'expédition traçable et assurée, à une société de services Pioneer autorisée ou à Pioneer. Utilisez des matériaux d'emballage coussinés adéquats pour éviter les dommages pendant le transport. Incluez votre nom, votre adresse et un numéro de téléphone où nous pouvons vous joindre pendant les heures de bureau.

Pour toute question concernant votre produit, veuillez contacter le soutien à la clientèle Pioneer comme décrit ci-dessus ou écrivez-nous à :

Customer Support, Pioneer Electronics (USA) Inc., P.O. Box 1720, Long Beach, California 90801 U.S.A.

RÈGLEMENT DES CONFLITS

Dans le cas d'un conflit entre vous et Pioneer après notre réponse à votre demande initiale adressée service à la clientèle (Customer Support), Pioneer met à votre disposition son Programme de résolution des plaintes pour résoudre le conflit. Le Programme de résolution des plaintes est disponible sans frais. Aux États-Unis, vous êtes tenu de recourir au Programme de règlement des plaintes avant d'exercer vos droits ou d'exiger réparation en vertu de la loi sur la garantie « Magnuson-Moss Warranty Act », mais vous êtes en droit d'engager une action en justice en vertu des lois de l'État sans passer par le Programme de résolution des plaintes. Pour avoir recours au Programme de résolution des plaintes, composez le 1-800-421-1404 et décrivez au représentant du service à la clientèle le problème que vous rencontrez et les démarches que vous avez entreprises pour faire réparer le produit pendant la période de garantie, et donnez-lui le nom du détaillant Pioneer autorisé auprès duquel vous vous êtes procuré le produit Pioneer. Une fois que votre plainte a été expliquée au représentant, un numéro de résolution vous sera communiqué. Pioneer étudiera le conflit et, dans un délai de quarante (40) jours après la réception de votre plainte, (1) répondra à votre plainte par écrit pour vous aviser des démarches qu'elle entreprendra pour résoudre le conflit, et indiquera combien de temps ces démarches prendront ; ou (2) répondra à votre plainte par écrit pour vous indiquer les raisons pour lesquelles Pioneer n'entreprendra aucune démarche.

ENREGISTREZ LE LIEU ET LA DATE D'ACHAT. VEUILLEZ GARDER CES INFORMATIONS ET VOTRE REÇU DE CAISSE DANS UN ENDROIT SÛR

N° de modèle _____ N° de série _____ Date d'achat _____

Acheté de _____