

PUNCH®

**UNIVERSAL BLUETOOTH
REMOTE**

PMX-BTUR



IPX6

Installation & Operation

Introduction

Dear Customer,

Congratulations on your purchase of the world's finest brand of audio products. At Rockford Fosgate we are fanatics about musical reproduction at its best, and we are pleased you chose our product. Through years of engineering expertise, hand craftsmanship and critical testing procedures, we have created a wide range of products that reproduce music with all the clarity and richness you deserve.

For maximum performance we recommend you have your new Rockford Fosgate product installed by an Authorized Rockford Fosgate Dealer, as we provide specialized training through Rockford Technical Training Institute (RTTI). Please read your warranty and retain your receipt and original carton for possible future use.

Great product and competent installations are only a piece of the puzzle when it comes to your system. Make sure that your installer is using 100% authentic installation accessories from Rockford Fosgate in your installation. Rockford Fosgate has everything from RCA cables and speaker wire to power wire and battery connectors. Insist on it! After all, your new system deserves nothing but the best.

To add the finishing touch to your new Rockford Fosgate image, order your Rockford accessories, which include everything from T-shirts to hats.

Visit our web site for the latest information on all Rockford products; www.rockfordfosgate.com or, in the U.S. call 1-800-669-9899 or FAX 1-800-398-3985. For all other countries, call +001-480-967-3565 or FAX +001-480-966-3983.

Table of Contents

2	Introduction
3	Specifications
4	Design Features and Functions
5	Battery Installation and Mounting Options
6	Troubleshooting
7-22	French, Spanish, German and Italian
23	Limited Warranty Information

If, after reading your manual, you still have questions regarding this product, we recommend that you see your Rockford Fosgate dealer. If you need further assistance, you can call us direct at 1-800-669-9899. Be sure to have your serial number, model number and date of purchase available when you call.

PRACTICE SAFE SOUND

Continuous exposure to sound pressure levels over 100dB may cause permanent hearing loss. High powered auto sound systems may produce sound pressure levels well over 130dB. Use common sense and practice safe sound.

Safety

This symbol with "WARNING" is intended to alert the user to the presence of important instructions. Failure to heed the instructions will result in severe injury or death.



This symbol with "CAUTION" is intended to alert the user to the presence of important instructions. Failure to heed the instructions can result in injury or unit damage.



To prevent injury and damage to the unit, please read and follow the instructions in this manual. We want you to enjoy this system, not get a headache.

If you feel unsure about installing this system yourself, have it installed by a qualified Rockford Fosgate technician.

Before installation, disconnect the battery negative (-) terminal to prevent damage to the unit, fire and/or possible injury.

FCC Compliance Statement

This equipment has been tested and found to comply with the limits for a Class B digital device, pursuant to part 15 of the FCC Rules. These limits are designed to provide more reasonable protection against harmful interference in a residential installation.

Operation is subjected to the following two conditions: (1) This device may not cause harmful interference, and (2) the device must accept any interference received, including interference that may cause undesired operation.

This equipment generates, uses, and can radiate radio frequency energy and, if not installed and used in accordance with the instructions, may cause harmful interference to radio communications. However, there is no guarantee that interference will not occur in a particular installation. If this equipment does cause harmful interference to radio or television reception, which can be determined by turning the equipment off and on, you are encouraged to try to correct the interference by one of the following measures:

- Reorient or relocate the receiving antenna.
- Increase the separation between the equipment and receiver.
- Connect the equipment into an outlet on a circuit different from that to which the receiver is connected.
- Consult the dealer or an experienced radio/TV technician for help

Model	PMX-BTUR
Operating Voltage	2.4V - 3.3V
Bluetooth	BLE4.2
Battery	CR2032

Pairing Instructions

Press any button on the remote to wake it up. Open the bluetooth setting menu in the device you wish to pair to. Toggle your devices bluetooth on if it is not already. Ensure your device is in searching mode and is looking for devices to pair to. In the available devices menu, look for PMX-BTUR and select it. Once your device finds the remote, it will ask if you would like to pair with the remote. If it is the first time pairing with this device, the remote will appear as accessory for IOS or XX:XX:XX:XX for Android (X's will be different for each PMX-BTUR unit). You will see three (3) green flashes from the LED then select pair and exit the settings menu.

Un-Pairing Instructions

Open the bluetooth setting menu in the device you wish to un-pair with. Select PMX-BTUR from the menu then select forget device. The red LED will flash twice (2) confirming the device is now successfully un-paired.

Once the remote is forgotten from the original device, press buttons 6-1-2-3 (Home Vol+ Vol- Play/Pause) within 3 seconds. If successful, the LED will illuminate yellow then green. The remotes history is now cleared so it can be paired to a new device. Follow pairing instructions above on new device.

Home Button LEDs

Green LED: The green LED will illuminate green for 1.5 seconds when a new battery has been installed.

Green LED: The green LED will blink three (3) times right before the user pressed pair on device.

Yellow then Green LED: Remote has been successfully cleared of its bluetooth history.

Red LED: The red LED will blink two (2) times when the remote is forgotten.

Red LED: Once the remotes battery has depleted to 35% or less, the red LED will come on solid and remain on.

Remote Wake Up/Sleep

After 15 seconds, if no buttons are pressed, the remote will automatically go into sleep mode to preserve battery life. To wake it back up, simply press any button on the remote once.

Compatible Devices

Rockford Fosgate PMX-1 (See PMX-1 manual for feature set when paired directly with PMX-BTUR).

iPhone Models (IOS 10 and above): 5, 5C, 5S, 6, 6 Plus, 6S, 6S Plus, 7, 7 Plus, 8, 8 Plus, X.

iPod Models: Touch (5th gen.), Touch (6th gen.)

Android (BT 5.0 and above): Bluetooth® Media Only.

Update Procedure

Periodically, an update may become available for the PMX-BTUR. To install the update onto your remote, simply open your mobile device, go to the Rockford Fosgate App and follow the instructions on screen.

Contents

- PMX-BTUR
- Steering Wheel Mount
- Standalone Hard Cover
- Soft Back Cover
- Velcro Tab
- Spare CR2032 Battery



CEA 2006

Power ratings on Rockford Fosgate source units conform to CEA-2006 industry standards. These guidelines mean your source unit's output power ratings are REAL POWER numbers, not inflated marketing ratings.

Design Features and Functions

HOME button (6)

INCOMING CALLS: Short pressing this button will answer/hang up incoming calls. Long pressing this button will reject an incoming call. (IOS ONLY)

LEDs: LED Indicator shows confirmation and status (see Home Button LEDs on page 3).

VOL UP button (1)

Short pressing this button will increase volume. Long pressing this button will quickly ramp the volume up.

TRACK UP button (5)

Pressing this button will skip forward to the next track. Hold this button to fast forward (IOS only).

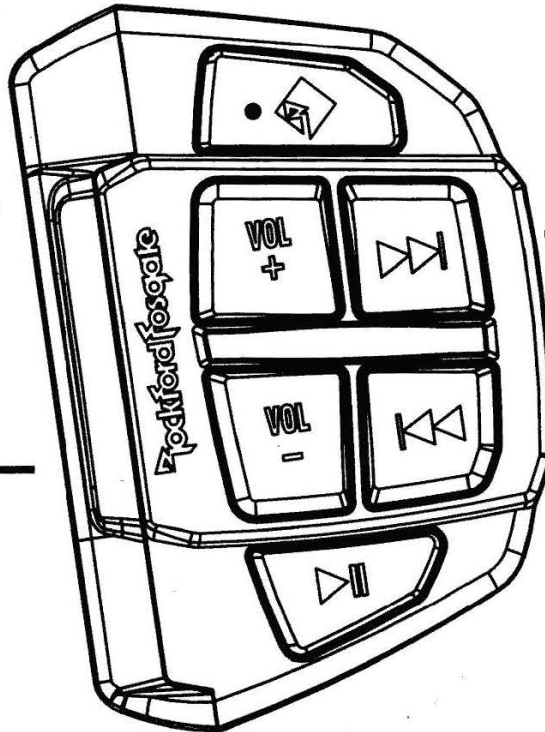

VOL DOWN Button (2)

Short pressing this button will decrease volume. Long pressing this button will quickly ramp the volume down.

TRACK DOWN button (4)

Short pressing this button once will go back to the previous track. Long pressing this button will rewind.

PLAY / PAUSE button (3)

Press this button to play or pause your music.

Long pressing this button activates hands free (speakerphone) (IOS ONLY)

Battery Installation and Mounting Options

Battery Installation

Remove rubber back cover and locate the (2) philips head screws on the side of the unit nearest to the track up and track down buttons. Loosen both screws and gently pull out the battery tray. Insert (1) CR2032 into the tray with the domed (-) of the battery facing up. You will notice on the underside of the tray there is a (+) molded into the tray. Make sure the positive + (flat side) of the battery is facing the same direction as the label on the tray. Slide the tray back into the unit and tighten the (2) phillips head screws. The LED will illuminate green for 1.5 seconds once the battery is installed to confirm the battery is good and the unit is operational.

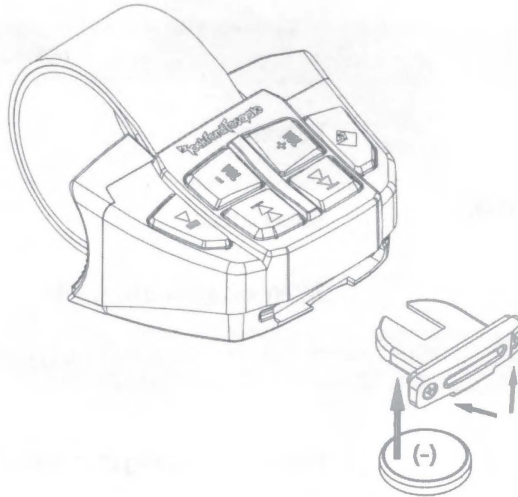

Release Tab and Standalone Option

To release the remote from the steering wheel mount, push the tab on the underside of the unit in the direction the arrow is pointing. While holding the tab, pull the unit straight up and out of the mount. If the unit is going to be used standalone and not fixed, included is a flat cover that slides on to the unit making it a mobile remote.

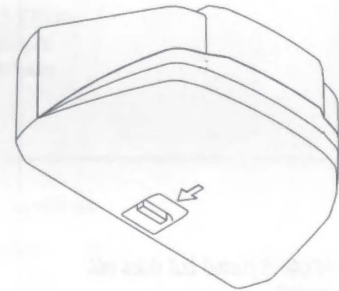
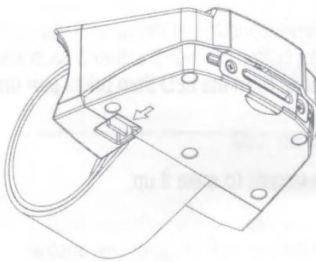

Steering Wheel/Bar Mount

Using the included velcro mounting adapter, hold the rubber side of adapter against the left hand inside of the steering wheel. Wrap the velcro strap around the wheel then insert it through the groove on the opposite side of the adapter. Wrap the straps extra slack around the wheel and secure it to the velcro. Finally, slide the unit into the adapter.

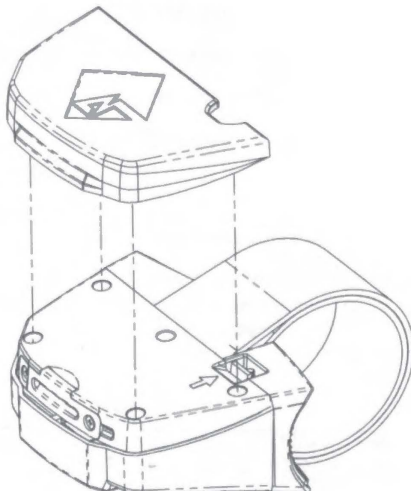
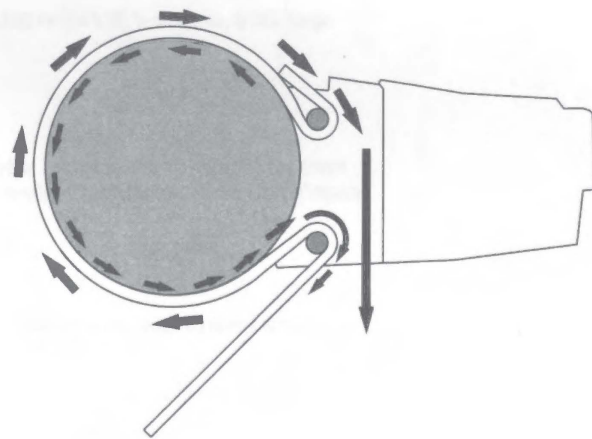

Back Cover

When using the remote with the steering/bar mount, you will need to attach the back cover. This will cover the battery tray and the back of the remote when not using it in the standalone option. Simply press the rubber studs into the existing holes on the back of the remote to secure it.:

Symptom	Diagnosis	Remedy
Basic		
Remote does not turn on	No battery	Insert battery (1 X CR2032) into unit.
	Battery is dead	Remove the old battery from unit and replace it with a new one.
	Battery was installed backwards	Remove the battery and reinstall it with the + side of the battery facing the same direction as the + symbol on the tray.
Bluetooth		
Remote will not pair	Remote is not showing up in bluetooth list	Press any button to wake the unit up. Ensure there is a healthy battery installed into the unit. Toggle bluetooth off then on in the devices bluetooth settings.
	Device being paired to is not in pairing mode	Turn bluetooth off then back on. Make sure the device is in searching mode.
	Remote is already paired to another device	Go to settings on your device and forget the remote from the bluetooths history. Press buttons 6-1-2-3 within 3 seconds and wait for 3 green flashes from the LED then press pair on the new device.
Remote is paired but does not respond	Remote went to sleep	Press any button on the remote to wake it up.
	Remote is out of range of device	Move remote/device within the 30 ft range of one another. (10m).
	Connection was lost	Unpair the device from the remote, Toggle the bluetooth off then back on. Try re-pairing to the remote.

Warranty

Rockford Corporation offers a limited warranty on Rockford Fosgate products on the following terms:

Length of Warranty

POWER Amplifiers – 2 Years
BMW® Direct Fit Speakers – 2 Years
PUNCH® & PRIME® Amplifiers – 1 Year
Speakers, Signal Processors, Accessories and Capacitors – 1 Year
All marine, motorcycle, motorsport products – 2 Years
Any Factory Refurbished Product – 90 Days (receipt required)

What is Covered

This warranty applies only to Rockford Fosgate products sold to consumers by authorized Rockford Fosgate dealers in the United States of America. Products purchased by consumers from an Authorized Rockford Fosgate Dealer in another country are covered only by that country's Distributor and not by Rockford Corporation.

Who is Covered

This warranty covers only the original purchaser of Rockford product purchased from an authorized Rockford Fosgate dealer in the United States. In order to receive service, the purchaser must provide Rockford with a copy of the receipt stating the customer name, dealer name, product purchased and date of purchase.

Products found to be defective during the warranty period will be repaired or replaced (with a product deemed to be equivalent) at Rockford's discretion.

What is Not Covered

1. Damage caused by accident, abuse, improper installation, operations, theft, water (on non-Element Ready products).
2. Any cost or expense related to the removal or reinstallation of product.
3. Service performed by anyone other than Rockford or an authorized Rockford Fosgate service center.
4. Any product which has had the serial number defaced, altered, or removed.
5. Subsequent damage to other components.
6. Any product purchased outside the U.S.
7. Any product not purchased from an authorized Rockford Fosgate dealer. Refer to rockfordfosgate.com dealer locator for more detail.

Limit on Implied Warranties

Any implied warranties including warranties of fitness for use and merchantability are limited in duration to the period of the express warranty set forth above. Some states do not allow limitations on the length of an implied warranty, so this limitation may not apply. No person is authorized to assume for Rockford Fosgate any other liability in connection with the sale of the product.

How to Obtain Service

Please call 1-800-669-9899 for Rockford Customer Service. You must obtain an RA# (Return Authorization number) to return any product to Rockford Fosgate. You are responsible for shipment of product to Rockford.

EU Warranty

This product meets the current EU warranty requirements, see your Authorized dealer for details.

— Installation assistance available at: —

RFTECH

— www.rockfordfosgate.com/rftech —

092517

1230-61814-01-A

Printed in China

600 South Rockford Drive • Tempe, Arizona 85281 United States
Direct: (480) 967-3565 • Toll Free: (800) 669-9899

ROCKFORDFOSGATE.COM

