

Thank you for purchasing the SXV300V1C SiriusXM Connect Vehicle Tuner Kit.

This kit comes with everything you need to add Satellite Radio to your SiriusXM-Ready headunit. Consult your headunit User Guide for features and detailed operational instructions.

For questions or support, please visit www.siriusxm.ca or call 1-888-539-7474.

What's In the Box?

The SXV300V1C kit includes the following:

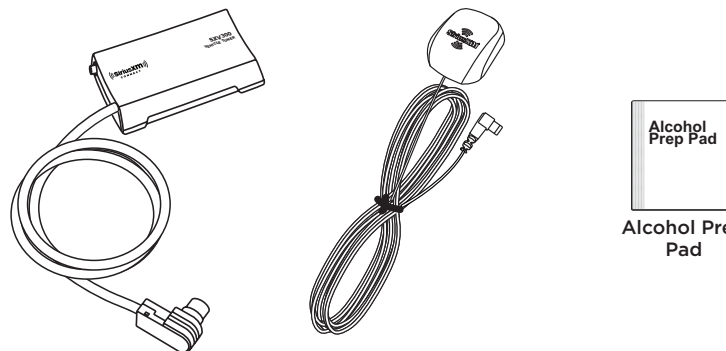

SXV300V1C Vehicle Tuner Magnetic Mount Antenna

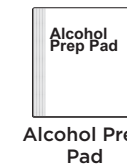

Alcohol Prep Pad

Check Your Headunit For Compatibility

If your headunit has the official SiriusXM-Ready logo it is compatible with the SXV300V1C Vehicle Tuner. All SiriusXM-Ready headunits include a dedicated connector, allowing for quick and easy connection of the SXV300V1C tuner.



Products with this logo are compatible



Products with these logos are not compatible

Install the Magnetic Mount Antenna

Proper placement of the Magnetic Mount Antenna is very important. Consult a professional installer if you are uncomfortable with installing the antenna yourself. More detailed installation instructions and illustrations can be found at siriusxm.ca/help.

- Locate the Magnetic Mount Antenna on the outside of your vehicle on a horizontal surface that always faces the sky.
- Avoid placing the antenna near obstacles that could block a clear view of the sky (such as roof racks, other antennas like AM/FM, cellular, and GPS), preventing the satellite signal from reaching the antenna.

Select the Best Location for the Magnetic Mount Antenna

For most vehicles the best location is on the roof, centered above the rear window or front windshield. Consult a professional installer to find an alternate antenna mounting location if your vehicle roof is made from a non-magnetic material such as aluminum, fiberglass, or carbon fibre.

- **Sedan or Coupe:** Recommended mounting location is above the rear window or front windshield.
- **Pickup or SUV:** Recommended mounting location is above the front windshield.
- **Convertible:** Recommended mounting location is above the front windshield, or alternately on the trunk lid, on the front hood, or on top of the front fender.

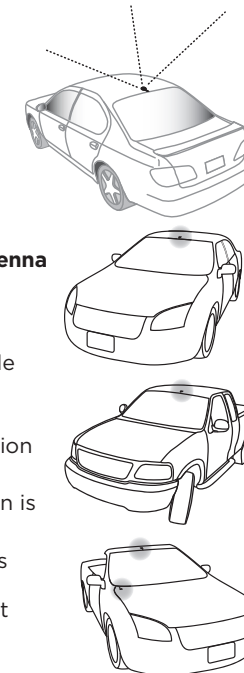

Route the Antenna Cable

Use care when routing the antenna cable into and through the vehicle interior, avoiding sharp objects that can damage the cable. Keep the antenna cable away from moving parts such as gas and brake pedals, trunk and door hinges, and sliding seat brackets.



Hide the antenna wire inside the vehicle cabin by routing the cable under the carpet and behind plastic trim, toward the headunit location. Coil and secure any excess cable in a hidden location, such as under the carpet, using wire ties (not included).

CAUTION! Do not kink or sharply fold the antenna cable.

1. Feed cable under rubber moulding and into weather-stripping around trunk opening.
2. Route cable out of window moulding and into weather-stripping around trunk opening.
3. Route cable along trunk wall and into cabin.
4. Route cable from trunk under interior trim, into cabin and towards front of vehicle.
5. Bring cable out from trim and route under carpet and behind the dash to the headunit. Coil and secure excess cable under carpet or behind dash.

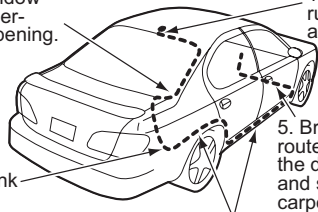

Make the Connections

You'll need to access the back of the SiriusXM-Ready headunit so you can plug the SXV300V1C Vehicle Tuner into it. This may require you to remove the headunit from the dashboard. If you are uncomfortable with this step, consult a professional installer.

Be sure to turn OFF the SiriusXM-Ready headunit before connecting the SXV300V1C Vehicle Tuner. Locate the SiriusXM connector on the headunit and connect the SXV300V1C. The headunit may have a panel mount type connector, or it may have a pigtail type connector.

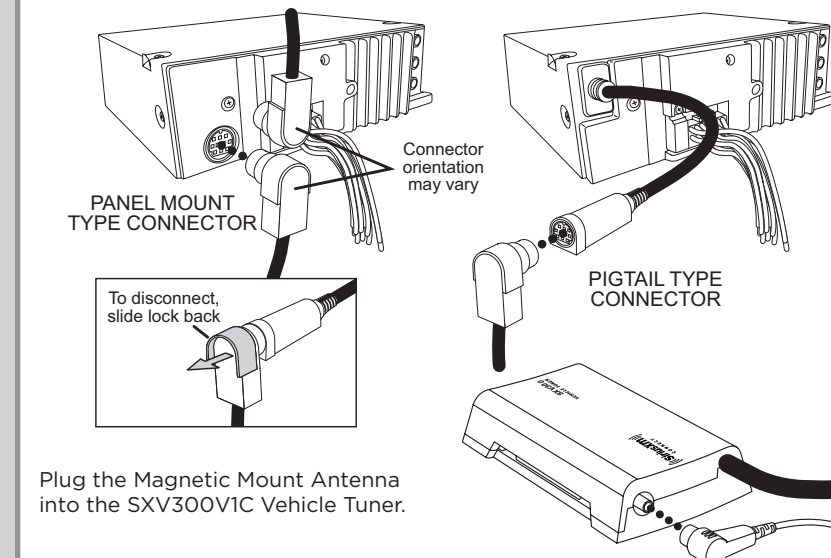

Plug the Magnetic Mount Antenna into the SXV300V1C Vehicle Tuner.

Secure the Tuner

Secure the SXV300V1C Vehicle Tuner behind the vehicle headunit location or under the dash using wire ties (not included).

Thread the wire ties through the molded brackets on the underside of the Tuner as shown. Then secure it to a bracket or wiring harness using the wire ties. Avoid brackets with sharp edges and any moving parts such as gas and brake pedals.

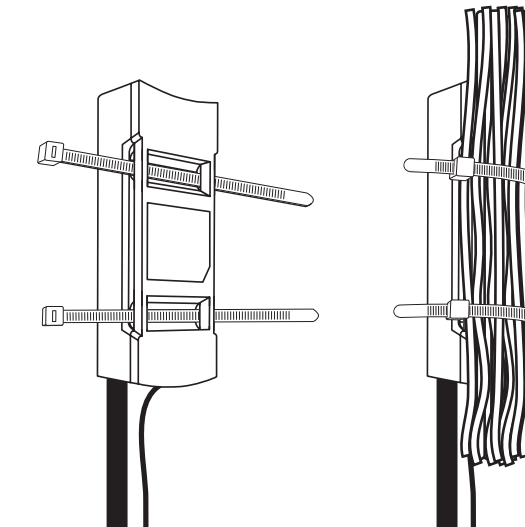

Reinstall the vehicle headunit if it had been removed from the dashboard.

Subscribe

You can subscribe to the SiriusXM service anytime by following these steps:

- 1 Make sure your vehicle headunit is turned on and that Satellite Radio is selected. Verify that you are receiving the SiriusXM signal so that you can hear the SiriusXM audio.
- 2 Make a note of your Radio ID. You can find it on channel 0, on a label on the bottom of the packaging, and on the label on the bottom of your SXV300V1C Vehicle Tuner.

NOTE! The Radio ID does not use the letters I, O, S, or F.

- 3 Activate your service:
 - First see our Customer Agreement for complete terms at www.siriusxm.ca and then:
 - Online: Go to siriusxm.ca/activate
 - OR
 - By phone: Call **1-888-539-7474**
- 4 Activation usually takes 10 to 15 minutes, but may take up to an hour. We recommend that your vehicle headunit remain on until subscribed. When your service is activated, you will see the **SUBSCRIPTION UPDATED, PRESS ENTER TO CONTINUE** or similar message displayed on the headunit. Once subscribed, you can tune to channels in your subscription plan.
- 5 Activation signals can be sent again at any time by visiting siriusxm.ca/refresh.

Troubleshooting

The troubleshooting information listed below is for general reference. Consult the User Guide for your SiriusXM-Ready headunit for specific operating instructions and advisory messages which may be displayed. Your headunit may display slightly different messages.

If you see this on the screen:	Try this:
No Signal (NoSignal)	<ul style="list-style-type: none"> • Make sure that the vehicle is outdoors with a clear view of the southern sky. • Make sure the Magnetic Mount Antenna is mounted outside of the vehicle. • Move your antenna away from any obstructed area. For example, if you are parked in an underground garage, you should receive a signal after leaving the garage.
Check Antenna (Chek Antenna, CHK Antena, Chek Ant)	<ul style="list-style-type: none"> • Make sure that the Magnetic Mount Antenna cable is firmly and securely plugged into the SXV300V1C Vehicle Tuner. • Make sure the antenna cable is not bent or broken. • Turn the headunit off, then on, to reset this message. If the message persists, most likely the antenna cable has been damaged. Replace the antenna.
Antenna Disconnected	Check the antenna connection to make sure it is fully plugged into the SXV300V1C Vehicle Tuner.
Antenna Cable Shorted	Replace the antenna.
Check Tuner (Chek Tuner, Chk Tunr)	Check the SXV300V1C Vehicle Tuner connection to the headunit and make sure it is plugged all the way in.
Channel Not Available (Chan Unavailable, Ch Unavailable, Ch Unavail, Ch Unavl)	The channel you have selected is not available.
Channel Not Subscribed (CH Unsubscribed, Chan Unsub, Ch Unsub)	The channel you have selected is not part of your current subscription plan. First see our Customer Agreement for complete terms at siriusxm.ca , and then call 1-888-539-7474 to subscribe.

7

Subscription Updated- Press enter to continue (or similar message)	Your subscription has been updated; press the appropriate button (or other identified key) to continue.
If this happens:	Try this:
You do not receive all the channels to which you subscribe	<ul style="list-style-type: none"> • If you have not yet activated your service, call 1-888-539-7474. • Go to siriusxm.ca/refresh and follow the directions to refresh your SXV300V1C Vehicle Tuner.
No song title or artist name is displayed	The information may not be available or updates may be in progress.
Traffic and Weather channels sound different from other channels	These channels use a different audio technology than other channels, so they often sound different from other channels.
Audio fades or has static when listening	<ul style="list-style-type: none"> • Check all the cables for a firm and secure connection. • Be sure that your headunit is correctly wired to the vehicle electrical system.

Specifications

Tuner

Dimensions	3.42 in (W) x 2 in (H) x 0.7 in (D) 87mm (W) x 51.8mm (H) x 17.9mm (D)
Weight	3 oz (85 g)
Pigtail Cable Length	25.6 in (650 mm)
Power Requirements	12v DC, 0.3 A (MAX) (supplied by headunit)
Operating Temperature	-4°F to +158°F (-20°C to +70°C)

Antenna

Type	Magnetic Mount
Connector	SMB
Cable Length	23 ft (7 m)

Network Operation XM Network

Specifications are subject to change without notice.

8

IC Statement

The user is cautioned that changes or modifications not expressly approved by SiriusXM Operation is subject to the following two conditions: (1) this device may not cause interference, and (2) this device must accept any interference, including interference that may cause undesired operation of the device. For product available in the Canada market, only channel 1-11 can be operated. Selection of other channels is not possible. This device and its antenna(s) must not be co-located or operation in conjunction with any other antenna or transmitter. To reduce potential radio interference to other users, the antenna type and its gain should be so chosen that the equivalent isotropically radiated power (e.i.r.p) is not more than that permitted for successful communication. IC Radiation Exposure Statement: This equipment complies with IC RSS-102 radiation exposure limits set forth for an uncontrolled environment. This equipment should be installed and operated with minimum distance 20cm between the radiator & your body.

WARNING! The FCC and FAA have not certified Satellite Radio Receiver use in any aircraft (neither portable nor permanent installation). Therefore, Sirius XM Radio Inc. cannot support this type of application or installation.

Patent Information

It is prohibited to, and you agree that you will not, copy, decompile, disassemble, reverse engineer, hack, manipulate, or otherwise access and/or make available any technology incorporated in this product. Furthermore, the AMBE® voice compression software included in this product is protected by intellectual property rights including patent rights, copyrights, and trade secrets of Digital Voice Systems, Inc. The software is licensed solely for use within this product. The music, talk, news, entertainment, data, and other content on the Services are protected by copyright and other intellectual property laws and all ownership rights remain with the respective content and data service providers. You are prohibited from any export of the content and/or data (or derivative thereof) except in compliance with applicable export laws, rules and regulations. The user of this or any other software contained in a SiriusXM radio is explicitly prohibited from attempting to copy, decompile, reverse engineer, hack, manipulate or disassemble the object code, or in any other way convert the object code into human-readable form.

9

Environmental Information

Follow local guidelines for waste disposal when discarding packaging and electronic appliances.

This product is packaged with cardboard, polyethylene, etc., and does not contain any unnecessary materials.

Copyrights and Trademarks

©2016 Sirius XM Canada Inc. Sirius, XM and all related marks and logos are trademarks of Sirius XM Canada Inc. All other marks and logos are the property of their respective owners. All rights reserved.

Important Legal Notice About Your Subscription

Hardware and subscription sold separately. **Service will automatically renew and bill at then-current rates until you call us at 1-888-539-7474 to cancel. See our Customer Agreement for complete terms at siriusxm.ca.** Fees and taxes apply. All fees and programming subject to change.

Important Legal Notice About Installation

Installation instructions are provided for your convenience. You must determine if you have the knowledge, skills, and ability required to properly perform installation. Professional installation is recommended. SiriusXM shall have no liability for damage/injury resulting from the installation/use of any SiriusXM or other products. You must ensure that all products are installed in adherence with local laws and regulations and in such a manner as to allow a vehicle to be operated safely and without distraction. SiriusXM product warranties do not cover the installation, removal, or reinstallation of any product.

10

SiriusXM 12-Month Limited Warranty

What This Warranty Covers

This warranty covers defects in material and workmanship for 12 months from the date of purchase by the original retail purchaser only. SiriusXM Canada Inc., at its sole option, will repair or replace the product with a new or reconditioned product without charge for parts and labour. Products replaced under this warranty become the property of SiriusXM. Replacement products are warranted to be free from defects for 30 days or the remainder of the original warranty, whichever is longer.

What This Warranty Does Not Cover

This warranty does not cover: products sold as used, as is, reconditioned or refurbished; software stored on internal or removable memory; non-rechargeable batteries, surface preparation cleaners, adhesive pads, fasteners, and ear-buds; costs incurred for installation, removal or reinstallation of the product; correction of installation problems, such as elimination of externally generated static or noise and antenna placement and aiming; defects or damage caused by alteration, improper installation or removal, use of third party accessories, mishandling, misuse, neglect, accident, power surges or acts of nature.

How to Obtain Warranty Service

To obtain warranty service, please call Customer Care at 1-888-539-7474. You will be required to provide proof of purchase and a description of the defect. You must prepay the cost of shipping the product to an approved service center.

LIMITATIONS OF LIABILITY

THE LIABILITY OF SIRIUSXM UNDER THIS WARRANTY IS LIMITED TO REPAIR OR REPLACEMENT AS PROVIDED ABOVE AND IN NO EVENT SHALL THE LIABILITY EXCEED THE PURCHASE PRICE PAID FOR THE PRODUCT. ANY IMPLIED WARRANTIES, INCLUDING ANY IMPLIED WARRANTY OF MERCHANTABILITY OR FITNESS FOR A PARTICULAR PURPOSE, SHALL BE LIMITED TO THE DURATION OF THIS WRITTEN WARRANTY. ANY ACTION FOR BREACH OF WARRANTY, INCLUDING BREACH OF ANY IMPLIED WARRANTY OF MERCHANTABILITY, MUST BE BROUGHT WITHIN 48 MONTHS FROM THE DATE OF ORIGINAL PURCHASE. IN NO CASE SHALL SIRIUSXM BE LIABLE FOR ANY CONSEQUENTIAL OR INCIDENTAL DAMAGES FOR BREACH OF THIS OR ANY OTHER WARRANTY, EXPRESS OR IMPLIED. SOME PROVINCES DO NOT ALLOW LIMITATIONS ON HOW LONG AN IMPLIED WARRANTY LASTS OR THE EXCLUSION OR LIMITATION OF INCIDENTAL OR CONSEQUENTIAL DAMAGES, SO THE ABOVE LIMITATIONS OR EXCLUSIONS MAY NOT APPLY TO YOU. This warranty gives you specific legal rights and you may also have other rights, which vary from province to province.

If you experience problems with the operation or performance of your product

DO NOT RETURN THIS PRODUCT TO YOUR RETAILER
Call Customer Care at 1-888-539-7474

Sirius XM Canada Inc.
135 Liberty St. - 4th floor
Toronto, Ontario, M6K 1A7
siriusxm.ca

1-888-539-7474

© 2016 Sirius XM Canada Inc.
SXV300V1C Installation Guide (SXV300V1G1010) 151116a



V300C Connect Vehicle Tuner INSTALLATION GUIDE

