

cerwin
vega
mobile



VEGA SERIES

**PASSIVE SPARE TIRE
SHALLOW SUBWOOFER**



US12SH

USER MANUAL

Introduction

Cerwin Vega Mobile Passive Shallow Spare Tire Subwoofer

Thank you for purchasing a Cerwin Vega Mobile Passive Shallow Spare Tire Subwoofer for your car audio system. You have chosen Cerwin Vega Mobile because you deserve the best!

Cerwin Vega Mobile products are designed and engineered to the highest quality standards in the industry to create the ultimate listening experience in your vehicle. For optimal performance of this product, it is highly recommended that you have your new subwoofer installed by an authorized Cerwin Vega Mobile dealer. Our authorized dealers have the necessary experience and installation equipment to ensure that your subwoofer will deliver maximum performance and explain all the details pertaining to your warranty coverage as well.

If you decide to install the subwoofer by yourself, please thoroughly read through this manual before getting started. This manual will help familiarize yourself with this amplified subwoofer and guide you through the installation process and procedures.

Please contact your local authorized Cerwin Vega Mobile dealer if you have any questions regarding the instructions in this manual or the amplifier's operation capabilities. If you require additional assistance, please contact the Cerwin Vega Mobile Technical Support Department during business hours at 213-261-4161.

Specifications

MODEL:	VS12SH
Power	300 WRMS/600 WMAX
Sensitivity	90dB
Frequency Response	20Hz - 500Hz
Impedance	Dual 4 Ohms
Subwoofer	11.3"
Mounting Length	14.2" (360mm)
Mounting Width	4.7" (119.38mm)

All specifications subject to change without notice.

Installation

This is a VERY simple install and can fit into virtually any car made in the last 10 years. WITHOUT removing your spare tire. Follow the instructions to a SUPER easy install!!

1. Remove the trunk liner. Typically it is NOT screwed or bolted down. It should simple pull out as shown below in Figure 1

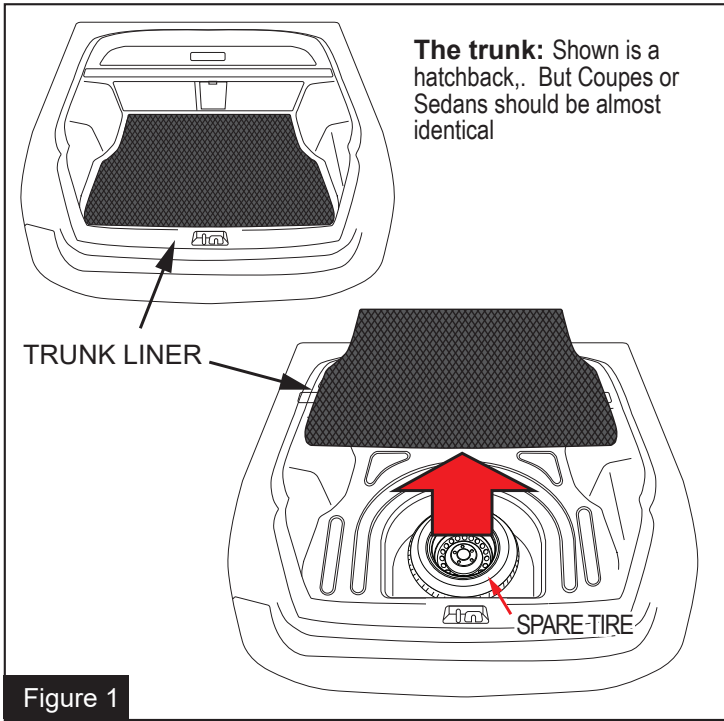

2. Once the trunk liner is removed and you can get access to your spare tire
Make a mental note if the spare tire is deep side down or deep side up???

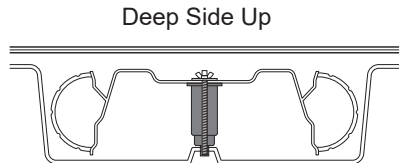
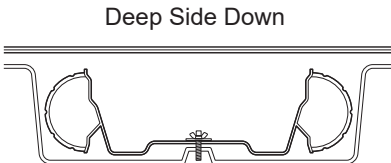

CAUTION!! Make sure to not drill or screw into vital vehicles components!!



FLIP OVER THE SPARE TIRE - IF NEEDED

1. IF your spare tire is Deep Side UP then you need to unbolt it and flip it over so the VS12SH can sit inside of it.
(See Figure 2)

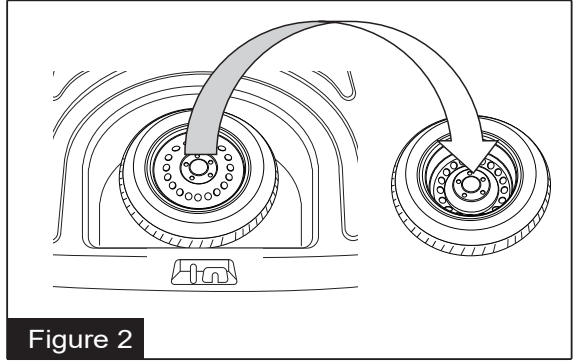

Figure 2

NO NEED TO FLIP OVER THE SPARE TIRE

2. IF your spare tire is Deep Side DOWN then you simply need to unbolt the spare tire and drop the VS12SH in so it can sit inside of it.
(See Figure 3)

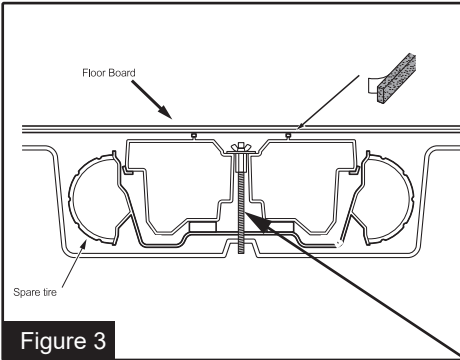

Figure 3

2. Make sure to check what size the mounting bolt is as the VS12SH comes with a 8mm and a 10mm mounting bolt. Which should fit 90% of all vehicles out today.

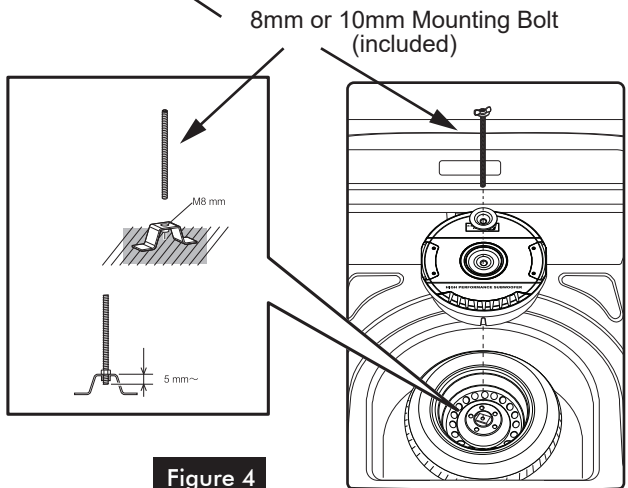

Figure 4

SPARE TIRE WITH ABS NUT (AUDI/VW TYPICALLY)

Using fix bolt and ABS Nut(supplied)

Some vehicles have a different type of spare tire mounting system as shown below. Where there is a large "NUT" and a bolt coming thru the center of the spare tire.

IF so....

1. Thoroughly clean the spare tire
2. Replace the original spare ABS fixing nut with the supplied one that came with the VS12SH

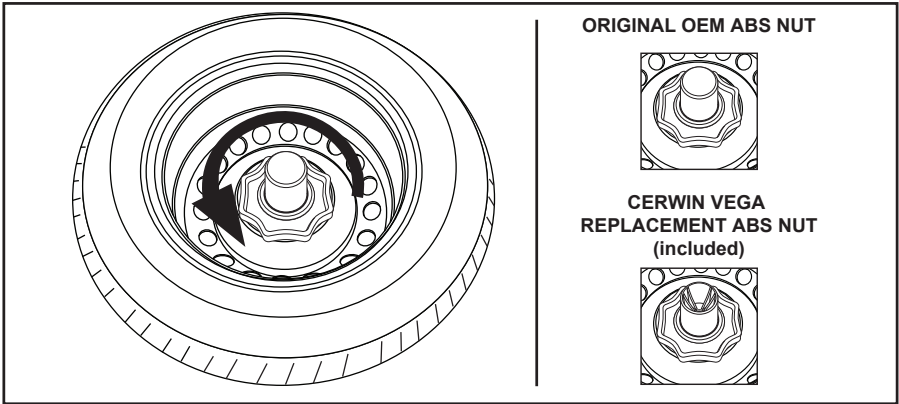

CONNECTING WIRING HARNESS

1. The VS12SH should be mounted into the spare tire area at this point.
2. Plug the speaker wire connector into the port in the handle area of the enclosure.

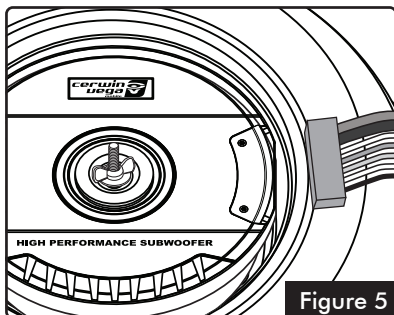
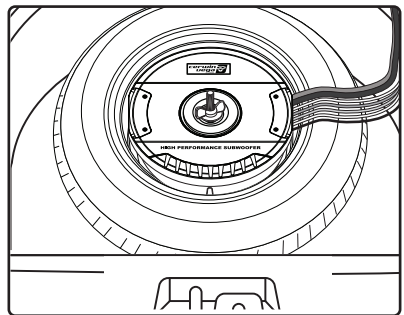

Figure 5



Warranty

Thank you for purchasing a Cerwin Vega Mobile product and we hope to provide you with countless hours of listening enjoyment.

Please take a brief moment to register your new product. By registering your new product, you will receive benefits such as:

- Important product notifications that may pertain to your purchase.
- Confirmation and record of ownership in case of loss or theft.
- Knowledgeable customer service and technical assistance pertaining to your product.

Register your new product by completely filling out this Product and Warranty Registration card or register online at www.cerwinvegamobile.com.

Registration is voluntary and failure to register will not diminish your limited warranty rights.

Limited Warranty (U.S.A.)

Cerwin Vega Mobile warrants all of our amplifiers and speakers to be free of defects in materials and workmanship for a period of one (1) year.

This warranty is non-transferable and applies only to the original purchaser from an authorized Cerwin Vega Mobile dealer. If service is required and necessary under this warranty due to manufacturing defect or malfunction, then Cerwin Vega Mobile will repair and/or replace defective product with either new or remanufactured like product at no charge at our discretion.

Damage to product caused by the following will not be covered under this warranty: abuse, accident, misuse, neglect, modifications, repairing attempts, seller/installer misrepresentation.

This warranty does not cover any incidental, consequential, or cosmetic damage due to accidents or normal wear and tear, nor does it cover the cost of removing or reinstallation of the product.

Warranty is void if the product's serial number has been removed, defaced, and/or tampered with.

Warranty Procedure:

We recommend that you contact your Cerwin Vega Mobile authorized dealer where your original purchase was made to initiate all warranty claims. Our authorized dealers can guide you through the warranty procedure to ensure that your claim will be processed in a timely manner. All warranty returns must be accompanied with a proof of purchase (a copy of the original sales receipt) and be shipped freight prepaid to our facility with an RA (Return Authorization) number clearly marked on the outside of the package. Direct returns from consumers or non-authorized dealers will be refused if shipped without a valid RA number authorized by Cerwin Vega Mobile beforehand.

INTERNATIONAL

Products purchased outside of the U.S.A. are covered only by that country's distributor and not by Cerwin Vega Mobile U.S.A.

Please Ship All Warranty Claims With Pre-Authorized RA Number To:

CV&DA Holdings, Inc.

ATTN: Customer Service Department

3761 S. Hill Street

Los Angeles, CA 90007 USA

Please Contact Customer Service for Further Warranty Information:

U.S.A.

Tel: 213-261-4161 / Direct Tech line 213-212-3176 / Fax: 213-947-4767



3761 S Hill Street • Los Angeles, CA 90007 USA
P 213-261-4161 • F 213-246-2423

WWW.CERWINVEGAMOBILE.COM

©2021 CVDA Inc. All Rights Reserved.
(a division of CV & DA Holdings, Inc.)