

# AQUATIC AV®

products with a watertight reputation

## AQ-MP-5UBT-HS - WATERPROOF MEDIA PLAYER

for SiriusXM, iPhone, iPod, USB, Bluetooth & MP3 devices

### USER / INSTALLATION MANUAL



Replaces Factory Radio on Harley-Davidson® Motorcycles  
(Models 1998-2013)



! PLEASE READ THIS INSTRUCTION MANUAL BEFORE  
INSTALLATION AND OPERATION !

- 1 Getting Started..... 4**
  - 1.1 Contents..... 4
  - 1.2 Connections..... 4
  - 1.3 Wiring Diagram..... 5
  - 1.4 Mounting Precautions..... 6
  - 1.5 Installing the Media Player if no stereo is already installed..... 6
  - 1.6 Installing the Media Player if an existing factory stereo is already installed..... 7
  - 1.7 Connecting Rear Speakers..... 7
  - 1.8 Handle Bar Controls..... 8
  - 1.9 Power On..... 8
- 2 Location of Controls..... 9**
  - 2.1 Media Player Controls..... 9
  - 2.2 Media Player Control Functions..... 10
- 3 Listening to Devices..... 11**
  - 3.1 Listening via Bluetooth..... 11
    - 3.1.1 Pair with Bluetooth Device..... 11
    - 3.1.2 Listening via Bluetooth Device..... 11
  - 3.2 Listening via USB..... 11
    - 3.2.1 Listening via USB (Apple Devices)..... 11
    - 3.2.2 Listening via USB Flash Drives..... 12
    - 3.2.3 USB Search..... 12
    - 3.2.4 Device Charging..... 12
  - 3.3 Listening via Auxiliary Input (3.5mm Jack)..... 12
  - 3.4 Adjusting Volume Level..... 12
- 4 Listening to SiriusXM® Satellite Radio..... 13**
  - 4.1 What is SiriusXM Satellite Radio?..... 13
  - 4.2 Activating SiriusXM Satellite Radio..... 13
  - 4.3 Storing Channel Presets..... 13
  - 4.4 Tuning to Channel Presets..... 14
  - 4.5 Removing Channel Presets..... 14
  - 4.6 REPLAY Playback..... 14
  - 4.7 Parental Control..... 14
  - 4.8 Reset / Restore Factory Defaults..... 14
  - 4.9 Direct Tune..... 15
  - 4.10 Channel Tune..... 15
  - 4.11 Category Tune..... 15
  - 4.12 Troubleshooting..... 15
- 5 Listening to FM/AM Radio..... 16**
  - 5.1 Enter FM/AM Radio Mode..... 16
  - 5.2 Scan or Seek FM/AM Radio Channels..... 16
  - 5.3 Saving Radio Channel to Memory..... 16
  - 5.4 Listening to Saved Radio Memory..... 16
  - 5.5 Switching between FM Tuning Areas..... 16

- 6 Settings Menu..... 17**
  - 6.1 Audio Menu..... 17
  - 6.2 Clock Settings..... 17
  - 6.3 Local/Distant Tuning..... 17
  - 6.4 Stereo/Mono..... 17
  - 6.5 FM Tuning Area..... 18
  - 6.6 Beep Tone..... 18
  - 6.7 Day/Night Mode..... 18
  - 6.8 Dimmer High/Low..... 18
  - 6.9 System Reset..... 18
- 7 Additional Features..... 19**
  - 7.1 External 12V Triggers..... 19
  - 7.2 Connecting Multiple Amplifiers or High Current Draw Lighting Systems..... 19
- 8 Specifications & Dimensions..... 20**
  - 8.1 Specifications..... 20
  - 8.2 Dimensions..... 20
- 9 Warranty Information..... 21**

## 1.1 Contents

- AQ-MP-5UBT-HS Media Player
- Dummy Faceplate/Dust Cover
- AQ-USB-1 USB Input Socket
- Four-pin Speaker Wiring Harness
- User / Installation Manual

## 1.2 Connections (see also '1.3 Wiring Diagram')

### 1. 23-pin Harley-Davidson® Standard Harness Connection

The 23-pin harness supplies power and ground connections to the Media Player and two speaker channel output connections from the Media Player.

### 2. FM/AM Radio Antenna Jack

Allows connection of FM/AM radio antenna. For best FM/AM performance make sure the antenna is extended to the highest achievable position.

### 3. Front Auxiliary RCA Outputs

RCA pre-outputs allow connection to an external amplifier to power additional speakers on front channels.

### 4. Rear Auxiliary RCA Outputs

RCA pre-outputs allow connection to an external amplifier to power additional speakers on rear channels.

### 5. Auxiliary RCA Inputs

Allows an additional RCA input from a standalone unit or another source.

### 6. Subwoofer Output

Allows powered (active) subwoofer to be connected via RCA connector.

### 7. 12V DC External Trigger (x2)

Allows for external lighting or relays to be triggered (350mA max load).

### 8. USB Charging Input

Charges USB devices when connected.

### 9. SiriusXM Satellite Radio Input

Allows the connection of the SiriusXM-Connect Vehicle Tuner (sold separately).

### 10. Power Antenna / Amplifier Remote Wire

Provides 12V+ signal to turn on an external amplifier.

### 11. Rear Channel High-Level (Speaker) Output

High-level rear channel speaker output (refer to 1.7).

## 1.3 Wiring Diagram

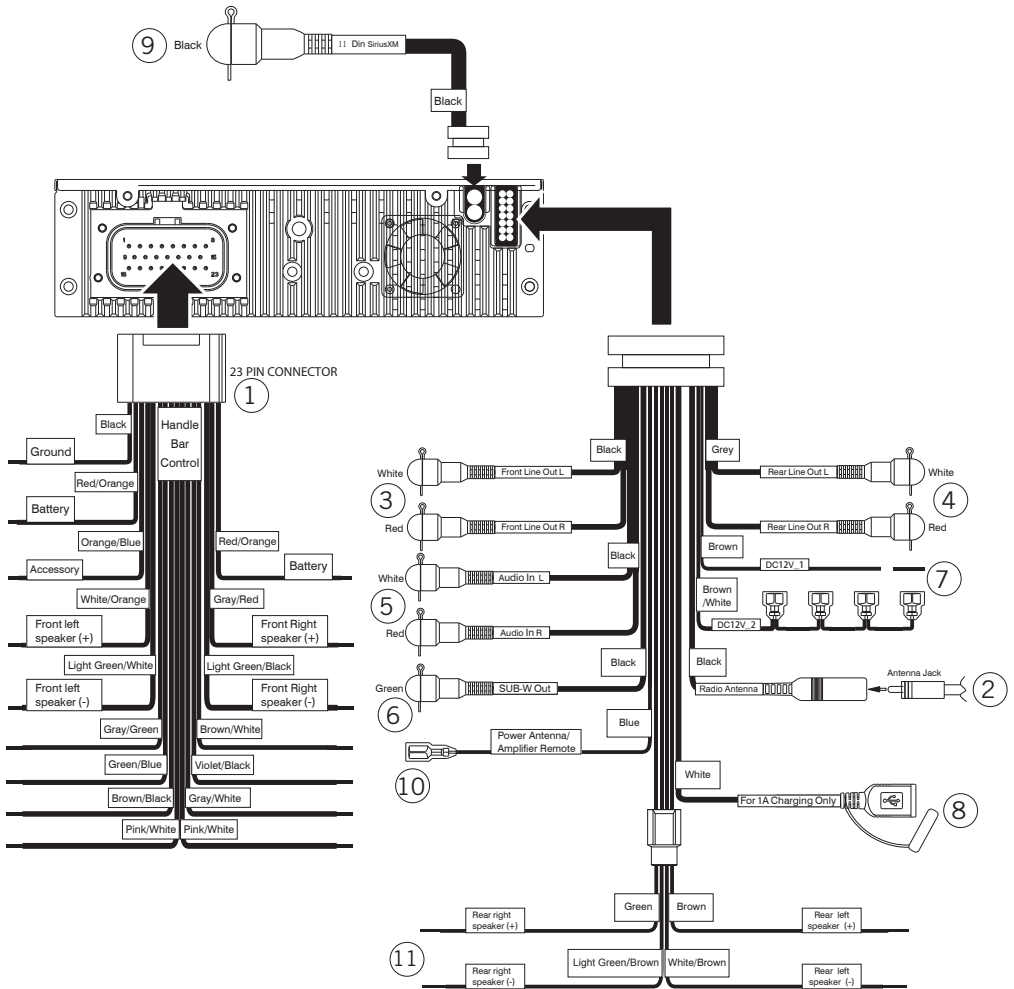

No lower than a 2 Ohm load should be used or damage may occur to the Media Player.

Make sure the polarity of speakers are connected correctly.

## 1.4. Mounting Precautions

Please observe the following precautions:

1. Install the unit where it does not interfere with driving.
2. Check clearances on both sides of a planned installation before drilling any holes or installing any screws.
3. When routing RCA cables, keep them away from power cables and speaker wires.

**i** A common source of noise in the audio system is the motorcycle ignition system. This is usually due to the radio being located close to the ignition system (engine). This type of noise is detectable by a varying pitch with the speed of the engine.

Ignition noise can be removed using a high voltage radio suppression type ignition wire and a suppressor resistor. Your motorcycle may already use this wire and resistor but it may be necessary to check them to ensure they are operating correctly. Alternatively, a noise suppressor could be installed.

## 1.5 Installing the Media Player if no stereo is already installed

Use the existing Harley-Davidson® factory side mounting brackets and hardware to mount the Media Player.

1. Position the Media Player in front of the fairing opening so the wiring can be passed through the opening.
2. Follow the wiring diagram and ensure all connections are secure and insulated with crimp connectors to ensure proper operation.
3. Turn the Media Player on to confirm operation (motorcycle ignition switch must be on) and once correct operation is achieved turn the motorcycle ignition switch off before proceeding with the final mounting of the chassis.
4. Ensure that the unit is supported and secured on the sides using the existing 4 factory screws; failure to do so may allow the unit to move during while riding, causing damage to the mounting area.

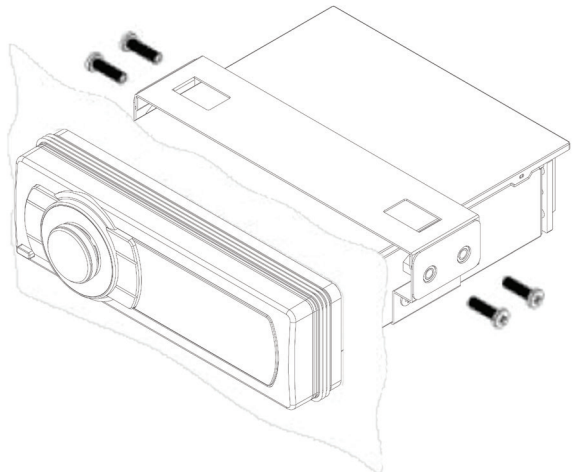

### 1.6 Installing the Media Player if an existing factory stereo is already installed

If replacing an existing Harley-Davidson® factory stereo use the existing Harley-Davidson® factory side mounting brackets and hardware to mount the Media Player.

1. Disconnect the radio harness and FM/AM radio antenna from the factory stereo.
2. Remove the factory stereo and replace with the AQ-MP-5UBT-HS Media Player using the existing factory mounting hardware.
3. Plug the 23-pin radio harness plug and FM/AM radio antenna into the AQ-MP-5UBT-HS Media Player. Only the 23-pin harness plug is utilized by the media player. Any additional harness plugs will hang loose in your fairing.
4. Turn the Media Player on to confirm operation (motorcycle ignition switch must be on) and once correct operation is achieved turn the motorcycle ignition switch off before proceeding with the final mounting of the chassis.
5. Ensure that the unit is supported and secured on the sides using the existing 4 factory screws; failure to do so may allow the unit to move during while riding, causing damage to the mounting area.

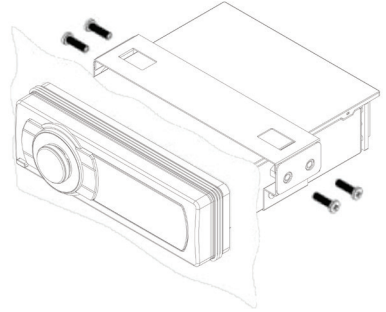

### 1.7 Connecting Rear Speakers

Rear speakers are usually installed on the following Harley-Davidson® Motorcycle models: *Electra Glide Ultra Classic, Road Glide Ultra, Ultra Limited*. To continue using these speakers with your Aquatic AV Media Player follow the instructions below.

1. Locate the rear channel high-level output (4-pin molex connector with four speaker wires). The pigtail itself is labelled with Color Code, Function and Description.
2. Locate the rear channel speaker lines in the 35-pin radio harness plug. This plug will not be connected to your Aquatic AV head unit. Cut the 4 speaker wires for the rear channels at pins 1 and 24(for the right side) and pins 2 and 25(for the left side)
3. Strip the 4-pin pigtail wires 1/4" exposing bare wires. Strip the 4 wires that you cut from the 35-pin harness 1/4" exposing bare wires.
4. Connect and crimp using crimp caps or solder the connection, cover the soldered wires with non conductive heat shrink tube.

**i** After following the installation instructions above test your rear speakers for sound. If you do not have output from your rear speakers make sure to check your rear speaker setting in the settings menu and select rear speakers 'ON'.

## 1.8 Handle Bar Controls

Audio switch (left hand side)

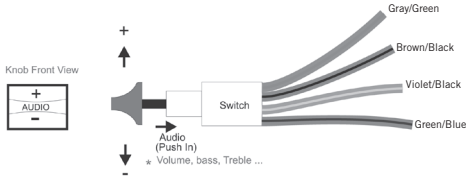

Mode switch (right hand side)

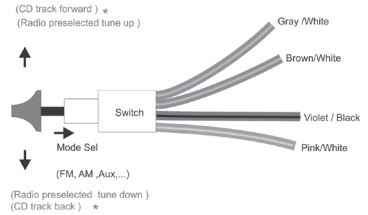

The AQ-MP-5UBT-HS is a plug and play solution for 1998-2013 Harley-Davidson® Motorcycles. Plug the standard Harley-Davidson® 23-pin connector in to the back of the AQ-MP-5UBT-HS and your speakers and hand controls will work the same as the standard factory install (some Harley-Davidson® models may require additional steps).

Some stock Harley-Davidson® features e.g. CB radio will not be supported through the AQ-MP-5UBT-HS.

Below is a matrix of what can be controlled on the AQ-MP-5UBT-HS via the stock Harley-Davidson® hand controls.

|               | Hand Control Up       | Hand Control Down         | Mode Select                     |
|---------------|-----------------------|---------------------------|---------------------------------|
| AM/FM         | Tunes to next station | Tunes to previous station | Switches Mode                   |
| Bluetooth/USB | Next Track            | Previous Track            | Switches Mode                   |
| AUX           | No function           | No function               | Switches Mode                   |
| SiriusXM      | Next Channel          | Previous Channel          | Switches Mode                   |
|               | ( + )                 | ( - )                     | Audio                           |
| AM/FM         | Turns volume up       | Turns volume down         | Accesses Audio Menu adjustments |
| Bluetooth/USB | Turns volume up       | Turns volume down         | Accesses Audio Menu adjustments |
| AUX           | Turns volume up       | Turns volume down         | Accesses Audio Menu adjustments |
| SiriusXM      | Turns volume up       | Turns volume down         | Accesses Audio Menu adjustments |

## 1.9 Power On

The AQ-MP-5UBT-HS requires 12V DC to pins 10,20, and 12 in the 23-pin radio harness plug in order to power up. Ground should be connected to pin 11.

Once all connections are made press the rotary knob and the stereo will turn ON.



## 2.1 Media Player Controls

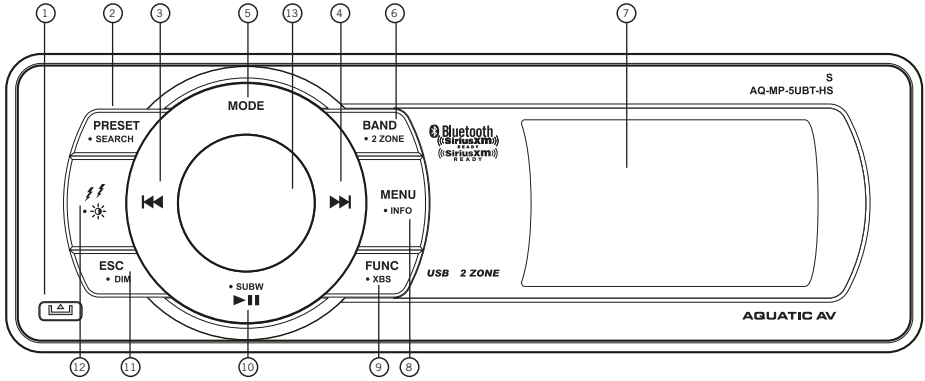

- |                       |                |                  |                        |
|-----------------------|----------------|------------------|------------------------|
| 1. Front face release | 5. Mode        | 8. Menu/Info     | 11. ESC/Dimmer         |
| 2. Preset/Search      | 6. Band/2-Zone | 9. Function/XBS  | 12. 12V Trigger /      |
| 3. Previous/Rewind    | 7. LCD screen  | 10. Play/Pause / | Day/Night Mode         |
| 4. Next/Fast Forward  |                | Subwoofer        | 13. Rotary Select Knob |

## 2.2 Media Player Control Functions

| Button                     |             | AM/FM Mode   | Aux In      | Bluetooth                | USB                      | SiriusXM®<br>Satellite Radio                 |
|----------------------------|-------------|--|-------------|--------------------------|--------------------------|--|
| Rotary Select Knob         | Short Press | Mute   |             |                          |                          |  |
|                            | Long Press  | Power Off  |             |                          |                          |  |
|                            | Short Press | When system is Off, this will power back On<br>In MENU: Select |             |                          |                          |  |
| Mode                       | Short Press | Enter mode select screen or switches to next source            |             |                          |                          |  |
|                            | Long Press  | No Function  |             |                          |                          |  |
| Rotary Knob Clockwise      |             | Volume increases<br>In MENU: Next/Down                         |             |                          |                          |  |
|                            |             | Volume decreases<br>In MENU: Previous/Up                       |             |                          |                          |  |
| Next                       | Short Press | Scans to the next station                                      | No Function | Changes to next song     | Changes to next song     | Next Station                                 |
|                            | Long Press  | Switches into manual seek mode                                 | No Function | No Function              | No Function              | Skip forward in Replay Mode<br>Rapid Channel |
| Previous                   | Short Press | Scans to the previous station                                  | No Function | Changes to previous song | Changes to previous song | Previous Station                             |
|                            | Long Press  | Switches into manual seek mode                                 | No Function | No Function              | No Function              | Skip Back in Replay Mode<br>Rapid Channel    |
| Play/Pause/Subwoofer       | Short Press | No Function  | No Function | Toggles Play/Pause       | Toggles Play/Pause       | Play/Pause SiriusXM                          |
|                            | Long Press  | Displays Subwoofer volume                                      |             |                          |                          |  |
| Band/2 Zone                | Short Press | Switches between AM/FM Bands                                   | No Function | No Function              | No Function              | SXM1, SXM2, SXM3                             |
|                            | Long Press  | Toggles 2 Zone selection menu                                  |             |                          |                          |  |
| 12V Trigger/Day/Night Mode | Short Press | Toggles 12V Trigger menu                                       |             |                          |                          |  |
|                            | Long Press  | Toggles Day/Night Mode   |             |                          |                          |  |
| FUNC/XBS                   | Short Press | Access AM/FM Tuner Options                                     | No Function | No Function              | Access USB Options       | Access SiriusXM Options                      |
|                            | Long Press  | Toggles XBS ON/OFF   |             |                          |                          |  |
| ESC/DIM                    | Short Press | Returns you to the Previous Screen                             |             |                          |                          |  |
|                            | Long Press  | Enables the Two Stage Dimmer                                   |             |                          |                          |  |
| PRESET/SEARCH              | Short Press | Displays your presets  | No Function | No Function              | Toggles Search feature*  | Displays your presets                        |
|                            | Long Press  | Auto Store station preset                                      | No Function | No Function              | No Function              | No Function                                  |
| MENU/INFO                  | Short Press | Toggles system menu  |             |                          |                          |  |
|                            | Long Press  | No Function  | No Function | No Function              | No Function              | No Function                                  |

\* iPod & iPhone only

**i** If your music player is connected via the Auxiliary input you will not be able to control track or receive track information.

**i** Turn off DSP to access control of Bass and Treble

## 3.1.1 Pair with Bluetooth Device

1. Open the Bluetooth settings on your Bluetooth enabled device.
2. Turn on Bluetooth on device.
3. Select 'AQUATIC AV' from the list of available devices to pair (no password is needed).
4. A Bluetooth logo will illuminate on the Media Player LCD to verify Bluetooth is activated.

**i** *Only one Bluetooth device can be paired with the Media Player at any time.*

## 3.1.2 Listening via Bluetooth Device

1. After pairing a Bluetooth enabled device, switch the media player to Bluetooth Mode.
2. Media played on your paired device, will be transmitted to the Media Player.
3. The Play/Pause, Next, and Previous buttons will control their appropriate functions on your device
4. A paired Bluetooth device can be controlled through the controls on the device, the faceplate controls, or using the handle bar controls.

## 3.2 Listening via USB

### 3.2.1 Listening via USB (Apple Devices)

1. Remove the faceplate and press the lever in the lower right corner of the unit to release the tray mechanism.
2. Set the iPod/iPhone in the mechanism and adjust the clamps to hold it secure.
3. Plug the iPod/iPhone cable into the USB input, and tuck the cable in so the faceplate can be reattached.
4. Replace the faceplate. If the stereo was previously on it will come back on. If not press the Rotary Knob to power the unit on.
5. Press the Mode button and select USB Mode.

## 3.2.2 Listening via USB Flash Drives

1. Remove the faceplate and press the lever in the lower right corner of the unit to release the tray mechanism.
2. Plug the USB drive in the USB port.
3. Replace the faceplate. If the stereo was previously on it will come back on. If not press the Rotary knob to power it on.
4. Press the Mode button and select USB Mode.

## 3.2.3 USB Search

1. When using an iPhone, iPod or USB flash drive press SEARCH to enter USB searching mode.
2. Once in searching mode the menu will display 'Playlist'. Use the Rotary Knob to scroll through the search modes below:
  - 1) Playlist 2) Artist 3) Album 4) Song 5) Genre 6) Composer 7) Audio Book(USB flash drives will display the names of your folders)
3. Press the Rotary Knob to select the desired search mode and continue in this manner to navigate the menu sub-folders.
4. Use and FAST REWIND/FAST FORWARD to navigate through your menu page by page.

## 3.2.4 Device Charging

When specified USB devices are connected to either the internal USB input or the rear USB charging cable, the device battery will charge.

## 3.3 Listening via Auxiliary Input (3.5mm Jack)

1. Remove the faceplate from the stereo.
2. Connect your MP3 device to the 3.5mm connector.
3. Re-attach the faceplate.
4. Press the rotary knob to power the Media Player ON (if the faceplate was removed with the stereo still powered on, it will power on by itself).
5. Press (MODE) on the Media Player or remote control to select 'AUX -1' mode.

 *Always ensure to connect and disconnect your Media Player with dry hands!*

## 3.4 Adjust Volume Level

1. Turn the rotary knob clockwise increase the volume.
2. Turn the rotary knob counter clockwise to reduce the volume.

## 4.1 What is SiriusXM Satellite Radio?

Only SiriusXM® brings you more of what you love to listen to, all in one place. Get over 140 channels, including commercial-free music plus the best sports, news, talk, comedy and entertainment. Welcome to the world of satellite radio.

A SiriusXM-Connect Vehicle Tuner and subscription are required.

For more information, visit [www.siriusxm.com](http://www.siriusxm.com)

## 4.2 Activating SiriusXM Satellite Radio

The SiriusXM Radio ID is required for activation and can be found by tuning to Channel 0 as well as on the label found on the SiriusXM-Connect Vehicle tuner and its' packaging. The Radio ID does not include the letters I, O, S or F.

**i** For more information on how to install the SiriusXM Connect Vehicle tuner, consult the installation guide included with the tuner

After installing your SiriusXM-Connect Vehicle Tuner and antenna, power on the Media Player, press the MODE button and select SiriusXM mode.

You should be able to hear the SiriusXM preview channel on Channel 1. If you cannot hear the preview channels, please check the installation instructions to make sure your SiriusXM-Connect tuner is properly installed.

After you can hear the Preview channel, tune to Channel 0 to find the Radio ID of your tuner.

In the USA, you can activate online or by calling SiriusXM Listener care:

- Visit [www.siriusxm.com/activatenow](http://www.siriusxm.com/activatenow)
- Call SiriusXM Listener Care at 1-866-635-2349

For Canadian Subscriptions, please contact:

- Visit [www.siriusxm.ca/activatexm](http://www.siriusxm.ca/activatexm)
- Call XM customer Care at 1-877-438-9677

As part of the activation process, the SiriusXM satellites will send an activation message to your tuner. When your radio detects that the tuner has received the activation message, your radio will display: "Subscription Updated".

Once subscribed, you can tune to channels in your subscription plan. Note, the activation process usually takes 10 to 15 minutes, but may take up to an hour. Your radio will need to be powered on and receiving the SiriusXM signal to receive the activation message.

## 4.3 Storing Channel Presets

1. Select the channel you would like to store.
2. Press the FUNC button, then select 'Add Preset' to select one of the 6 presets.
3. When in the main screen, press BAND to select between SXM1, SXM2 & SXM3.
4. Repeat steps above to store up to 18 total stations within SiriusXM mode.

**i** A total of 18 channels can be stored in the preset memory.

## 4.4 Tuning to Channel Presets

1. Press BAND to select the SXM1, SXM2 or SXM3.
2. Press PRESET then use the rotary knob and rotate to the desired station.

## 4.5 Removing Channel Presets

1. Press BAND to select the SXM1, SXM2 or SXM3.
2. Press FUNC, then select 'Remove Preset'.
3. Select the desired preset to be removed.

## 4.6 REPLAY Playback

- Play/Pause: Using the Play/Pause button will allow the user to Play/Pause live audio.
- Skip Track Backward: Short press the Fast Rewind button.
- Skip Track Forward: Short press the Fast Forward button.
- Fast rewind: Press and hold the Fast Rewind button.
- Fast forward: Press and hold the Fast Forward button.
- Press FUNC then select 'Jump to Live' to resume back to live audio.

## 4.7 Parental Control

Parental Control allows you to prevent unauthorized access to selected channels you select. When enabled, the Parental Control feature requires you to enter a passcode to unlock any locked channels.

1. Press FUNC then select 'Parental Controls'.
2. To select Parental Controls On/Off press the encoder to 'Enter'.
3. Using the Encoder rotate to select the default code "1111".
4. To lock channels press FUNC then select 'Parental Controls' then 'Lock Channels'.
5. Use the encoder to rotate to selected channels and press 'Enter'.
6. To remove channels from the lock list follow steps 1 to 5 above, but select Unlock instead of Lock.
7. To change Pass Code, Press FUNC then select 'Parental Controls' then select 'Change My Code'.

**i** If you forget your passcode, press MENU, select SYSTEM, then select RESET. Understand that when you perform a RESET, all previously stored preset channels and audio settings in memory will be cleared. Once a RESET is performed, the Parental Control pass code will be reset to the default code (1111).

## 4.8 Reset / Restore Factory Defaults

1. Short press MENU then select 'SYSTEM' using the rotary encoder.
2. Select 'RESET' and press the rotary encoder to 'Enter'.
3. Select 'SXM RESET' and press the rotary encoder to 'Enter'.

**i** Restoring the factory default settings will reset the last channel tuned, preset stations, display settings, locked channels, parental control code and disable parental control. The parental control pass code will be reset to '1111'.

## 4.9 Direct Tune

Press FUNC then select 'Direct Tune', using the rotary knob. Rotate to select each number you would like to access (e.g. for channel 101; rotate first digit to 1 then press Enter, rotate second digit to 0 then press Enter, rotate last digit to 1 and press Enter. Channel 101 is now selected).

## 4.10 Channel Tune

Tuning to a specific channel can be done in three ways:

1. Short press the NEXT button to go up to the next available station.
2. Short press the PREVIOUS button to go down to the next available station.
3. Press FUNC, CHANNEL then using the rotary knob, rotate counter clock wise to go down to the next available channel or clockwise to go up to the next available channel.
4. Long press the NEXT button for Rapid Channel function.
5. Long press the PREVIOUS button for Rapid Channel function.

## 4.11 Category Tune

1. Press FUNC and select 'Category'.
2. Using the encoder rotate to select the category desired
3. Press Enter, then select the channel desired.

## 4.12 Troubleshooting

| Message                | Description  |
|------------------------|--|
| Check Antenna          | The radio has detected a fault with the SiriusXM antenna. The antenna cable may be either disconnected or damaged. Verify that the antenna cable is connected to the SiriusXM Connect Vehicle Tuner. Inspect the antenna cable for damage and kinks. Replace the antenna if the cable is damaged. SiriusXM products are available at your local car audio retailer or online at <a href="http://www.shop.siriusxm.com">www.shop.siriusxm.com</a> .   |
| Check Tuner            | The radio is having difficulty communicating with the SiriusXM Connect Vehicle Tuner. The tuner may be disconnected or damaged. Verify that the SiriusXM Connect Vehicle Tuner cable is securely connected to the radio.   |
| No Signal              | The SiriusXM Connect Vehicle Tuner is having difficulty receiving the SiriusXM satellite signal. Verify that your vehicle is outdoors with a clear view of the sky. Verify that the SiriusXM magnetic mount antenna is mounted on a metal surface on the outside the vehicle. Move the SiriusXM antenna away from any obstructions. Inspect the antenna cable for damage and kinks. Consult the SiriusXM Connect Vehicle tuner installation manual for more information on antenna installation. Replace the antenna if the cable is damaged. SiriusXM products are available at your local car audio retailer or online at <a href="http://www.shop.siriusxm.com">www.shop.siriusxm.com</a> . |
| Subscription Updated   | The radio has detected a change in your SiriusXM subscription status. Press the ENTER button to clear the message. Visit <a href="http://www.siriusxm.com">www.siriusxm.com</a> or call 866-635-2349 if you have questions about your subscription.  |
| Channel Not Available  | The channel that you have requested is not a valid SiriusXM channel or the channel that you were listening to is no longer available. You may also see this message briefly when first connecting a new SiriusXM Connect Vehicle tuner. Visit <a href="http://www.siriusxm.com">www.siriusxm.com</a> for more information about the SiriusXM channel lineup.   |
| Channel Not Subscribed | The channel that you have requested is not included in your SiriusXM subscription package or the channel that you were listening to is no longer included in your SiriusXM subscription package. Visit <a href="http://www.siriusxm.com">www.siriusxm.com</a> or call 866-635-2349 if you have questions about your subscription package or would like to subscribe to this channel.   |
| Channel Locked         | The channel that you have requested is Locked by the radio Parental Control feature. See the section on Parental Control, page 16 for more information on the Parental Control feature and how to access locked channels.  |

## 5.1 Enter FM/AM Radio Mode

1. Press the MODE button to switch your Media Player to Radio Mode.

## 5.2 Scan or Navigate FM/AM Radio Channels

1. Press the NEXT or PREVIOUS buttons to scan for the strongest radio signals in your area.
2. Press and hold the NEXT or PREVIOUS buttons to manually tune the radio to desired station.

## 5.3 Saving Radio Channel to Memory

1. Tune to the station you would like to be saved as a preset.
2. Press the FUNC button to enter the Function menu.
3. Select 'Manually Save Preset'.
4. Using the rotary knob you can select which preset slot you would like to save the current station to.
5. Press the rotary knob to confirm your selection.
6. Upon successfully saving a preset, the screen will display SAVED and the preset number selected will be shown in the right corner of the display.

**i** Presets are only for the current band you are on. Each band FM1, FM2, FM3, AM1 and AM2 has six presets for a total of 30 (18x FM & 12x AM).

## 5.4 Listening to Saved Radio Memory

1. Once the presets have been set either manually or using Auto Scan press the 'Preset' button to display your presets.

## 5.5 Switching between FM Tuning Areas

1. When in 'RADIO' mode.
2. Press the FUNC button to enter the Function menu.
3. Scroll to 'AREA' then press the rotary knob.
4. Use the Rotary Knob to scroll to the desired tuning Area and select by pressing the Rotary Knob.

**i** US mode will increase and decrease the FM frequency in steps of 0.2 MHz, e.g. 88.1, 88.3, 88.5 MHz.  
EUR mode will increase and decrease the FM frequency in steps of 0.05 MHz, e.g. 88.25, 88.30, 88.35 MHz.  
RUSS mode will increase and decrease the FM frequency in steps of 0.05 MHz, e.g. 88.25, 88.30, 88.35 MHz.  
LAT mode will increase and decrease the FM frequency in steps of 0.1 MHz, e.g. 88.2, 88.3, 88.4 MHz.  
ASIA mode will increase and decrease the FM frequency in steps of 0.1 MHz, e.g. 88.2, 88.3, 88.4 MHz.  
JAPAN mode will increase and decrease the FM frequency in steps of 0.1 MHz, e.g. 88.2, 88.3, 88.4 MHz.  
MID E mode will increase and decrease the FM frequency in steps of 0.05 MHz, e.g. 88.25, 88.30, 88.35 MHz.  
AUS mode will increase and decrease the FM frequency in steps of 0.1 MHz, e.g. 88.2, 88.3, 88.4 MHz.



## 6.1 Audio Menu

From the 'Audio Menu' you are able to change the bass, treble, balance, and fader.

1. To enter the 'Audio Menu' press the 'AUDIO/MENU' button.
2. In the 'Audio Menu' press the 'AUDIO/MENU' to scroll through all options.
3. To change the parameters use the rotary knob to adjust settings.

**i** Any changes made in the 'Audio Menu' are system wide so it will affect all modes.

## 6.2. Clock Settings

The clock can be adjusted from the clock settings menu in the system settings.

1. To change the time press MENU then use the rotary knob to navigate to SYSTEM settings then CLOCK SETTINGS. Use the rotary knob to adjust and set the time.
2. To switch the clock on or off press MENU then use the rotary knob to navigate to SYSTEM settings then CLOCK PRIORITY. Use the rotary knob to select either ON or OFF.

## 6.3 Local/Distant Tuning

When 'Local' is turned on the Media Player seeks to only the radio channels with strong signal strength. When 'Local' is turned off the Media Player will seek to all radio channels it receives signal from.

1. When in AM/FM mode press FUNC to access the 'Local/Distant Tuning' settings.
2. Use the rotary knob to adjust settings.

**i** When local is turned on the word 'Local' will appear in the upper right hand corner of the Media Player LCD.

## 6.4 Stereo/Mono

Change the output mode between stereo and mono. Some applications only accept a mono input.

1. When in AM/FM mode press FUNC to access the 'Stereo/Mono' settings.
2. Use the rotary knob to adjust settings.

## 6.5 FM Tuning Area

There are seven different tuning areas: USA, EUR, LAT, ASIA, MIDDLE EAST, AUSTRALIA, RUSSIA.

1. When in AM/FM mode press FUNC to access the 'AREA' settings.
2. Use the rotary knob to select your area.

## 6.6 Beep Tone

Beep tone plays when any button is pressed, it can be toggled on and off from this selection.

## 6.7 Day/Night Mode

Adjust the screen display for better visibility in day or night time operation.

To switch between Day and Night modes long press the 12V Trigger / Day/Night Mode button.

**i** *Clock display will always be Night mode regardless of the Day/Night Mode settings.*

## 6.8 Dimmer High/Low

Adjust the display brightness from 100% for normal operation to 30% brightness to reduce screen glare during night time operation.

## 6.9 System Reset

Restores all factory settings.

## 7.1 External 12V Triggers

Aquatic AV understands the need for more flexible remote applications. With the AQ-MP-5UBT-HS Media Player Aquatic AV has provided two independent 12V 'accessory' trigger, activated from the RF wireless remote. These could activate any 12V based device such as LED lighting.

In any operational mode, press the 12V Trigger button to activate. Press again to deactivate.

**i** Aquatic AV strongly recommend you speak to our technical service staff or your local Aquatic AV dealer if you are considering using this feature.

**⚠** Load on External Trigger should not exceed 350mA.

## 7.2 Connecting Multiple Amplifiers or High Current Draw Lighting Systems

### Wiring a Single Pull Single Throw (SPST) Relay

The SPST is necessary to protect the stereo in systems with multiple amplifiers. The AQ-MP-5UBT-HS remote and trigger wire provide 350mV. While this enough to power a single amplifier, complex systems with multiple amplifiers will require a SPST relay.

**Position 30:** requires 12VDC from the main power source (12V battery, power supply etc). This should be the same power source that is powering your stereo.

**Position 85:** this is where you connect your ground from your power source (12V battery, power supply, etc.) This should be the same ground reference as your stereo.

**Position 86:** position 86 is triggered 12V, and is sent when your stereo is powered on.

For Aquatic AV stereos position 86 can be connected to either the blue remote wire in the harness or the brown 12V trigger on the rear of the unit. The differences are below:

**Blue (recommended):** The blue (remote wire) provides a 12VDC output when the stereo is powered on. Meaning as soon as the stereo is powered on the blue wire sends 12VDC through the relay powering on the amplifier.

**Brown:** the brown (12V Trigger) provides 12VDC output when it is triggered via the lightning bolt icon on the faceplate or handheld remote. This setup is more advantageous is a more complex system with several zones, as it gives you control of when an amp is on or off.

**Position 87:** this is the 12VDC output that you will provide 12VDC to the remote turn on to the amplifiers in your system.

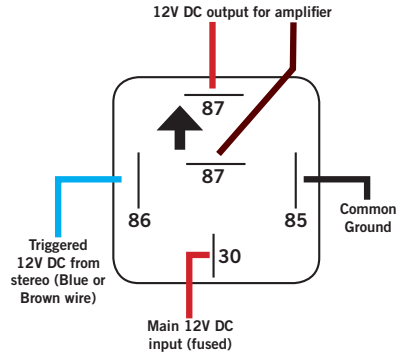

## 8.1 Specifications

### Media

Supported media.....Bluetooth / USB / MP3 / FM / AM / SiriusXM  
Supported media max. dimensions.....107 x 184mm (WxH)  
Device charging.....via USB

### Inputs

Auxiliary.....1x 3.5mm stereo Jack socket, 1x stereo pair RCA  
USB.....1x front (internal), 1x rear (external)

### Outputs

Pre-Out.....2x stereo pair RCA (4V)  
Subwoofer.....1x RCA (4V)  
12V Trigger.....2x 12V triggers (350mA)

### Power

Output voltage @ 2 Ohm.....4x 72W  
Output voltage @ 4 Ohm.....4x 45W  
Operation voltage.....9.6V - 14.4V DC  
Max current draw.....7A  
Standby current draw.....6mA

### Multi-Environment Certifications

Waterproof / Dustproof.....Yes - IP55  
Conformal PCB coating.....Yes  
UV protection.....500 hours stable, ASTM D4329 compliant  
Salt/Fog protection.....500 hours stable, ASTM B117 compliant  
Stainless Steel mountings.....Yes

## 8.2 Dimensions

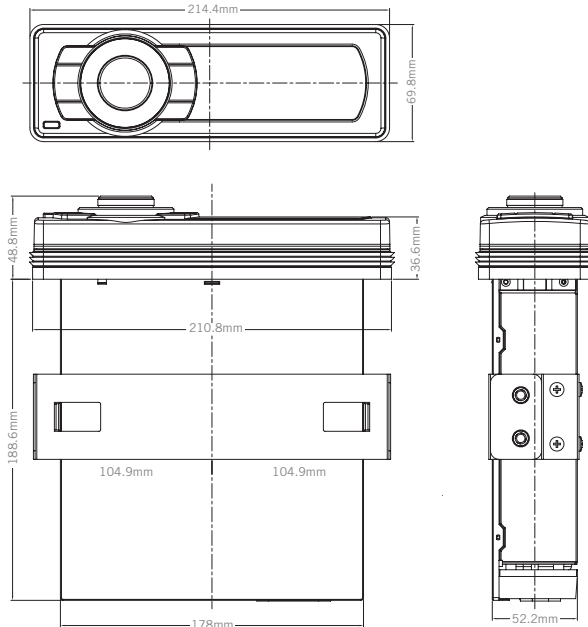

Aquatic AV offers a limited warranty of our products on the following terms:

**Length of warranty**

2 years on audio systems, electronics, speakers, and accessories (receipt required).

**Coverage**

This warranty covers only the original purchaser of an Aquatic AV product purchased from an authorized Aquatic AV dealer. In order to receive service, the purchaser must provide Aquatic AV with a copy of the receipt stating the customer name, dealer name, product purchased and date of purchase.

**Defective products**

Products found to be defective during the warranty period will be repaired or replaced (with a product deemed to be equivalent) at Aquatic AV's discretion.

**What is not covered**

Damage caused by accident, abuse, improper operations or theft. Any cost or expense related to the removal or reinstallation of product. Service performed by anyone other than an authorized Aquatic AV service center. Any product with the serial number or tamper labels defaced, altered, or removed. Subsequent damage to other components. Any product not purchased from an authorized Aquatic AV dealer.

**Limit on implied warranties**

Any implied warranties including warranties of fitness for use and merchantability are limited in duration to the period of the express warranty set forth above. Some states do not allow limitations on the length of an implied warranty, so this limitation may not apply. No person is authorized to assume for Aquatic AV any other liability in connection with the sale of the product.

**How to obtain service**

You must obtain a return material authorization number (RMA) to return any product to Aquatic AV. You are responsible for shipping charges of returned products to Aquatic AV.

Please record the model and serial number[s] of your equipment in the space provided below as your permanent record and will assist us with your factory warranty coverage. These numbers can be found on the rear of the stereo.

| Model number[s]: | Serial number[s]: |
|------------------|-------------------|
|                  |                   |
|                  |                   |
|                  |                   |

FCC ID:  
MADE IN CHINA

This device complies with Part 15 of the FCC Rules. Operation is subject to the following two conditions: (1) this device may not cause harmful interference, and (2) this device must accept any interference received, including interference that may cause undesired operation.

**NOTE:**

The equipment has been tested and found to comply with the limits for a Class B digital device, pursuant to Part 15 of the FCC Rules. These limits are designed to provide reasonable protection against harmful interference in a residential installation. This equipment generates, uses and can radiate radio frequency energy and, if not installed and used in accordance with the instructions, may cause harmful interference to radio communications. However, there is no guarantee that interference will not occur in a particular installation.

If this equipment does cause harmful interference to radio or television reception, which can be determined by turning the equipment off and on, the user is encouraged to try to correct the interference by one or more of the following measures:

- Reorient or relocate the receiving antenna.
- Increase the separation between the equipment and receiver.
- Consult the dealer or an experienced radio/TV technician for help.

The manufacturer is not responsible for any radio or TV interference caused by unauthorized modifications to this equipment. Such modifications could void the user authority to operate the equipment.



**California Proposition  
65 Warning**



**WARNING:** This product contains chemicals known to the State of California to cause cancer, and birth defects or other reproductive harm.

*For more information: [www.P65Warnings.ca.gov](http://www.P65Warnings.ca.gov)*

Patent: 8,578,081

iPhone and iPod are trademarks of Apple Inc., registered in the U.S. and other countries.

Made for iPod and Made for iPhone mean that an electronic accessory has been designed to connect specifically to iPod or iPhone respectively, and has been certified by the developer to meet Apple performance standards. Apple is not responsible for the operation of this device or its compliance with safety and regulatory standards. Please note that the use of this accessory with iPod or iPhone may affect wireless performance.

Sirius, XM, SiriusXM and all related marks and logos are trademarks of Sirius XM Radio Inc. All rights reserved.

Product design and specification subject to change without notice. E&OE.

Doc V7.1



## **Aquatic AV**

282 Kinney Drive  
San Jose, CA 95112, USA

**E-mail:** [info@aquaticav.com](mailto:info@aquaticav.com)

**US & Canada:** 1 877 579 2782

**International:** +1 408 559 1668

**Fax:** +1 408 559 0125

**[www.aquaticav.com](http://www.aquaticav.com)**

**AQUATIC AV<sup>®</sup>**  
products with a watertight reputation