

# iLoud<sup>®</sup> MTM **MKII**

USER MANUAL



## Table of Contents

<b>Contents</b>	2
<b>iLoud MTM MKII</b>	4
Register your iLoud MTM MKII	5
Safety Instructions	6
<b>Overview</b>	8
<b>Installation and setup</b>	9
<b>Control panel</b>	13
Audio inputs	13
Combo XLR-1/4" balanced line input	13
ARC Mic input	13
USB port	13
Power	13
Rear controls	14
LF extension	14
80 Hz low cutoff for bass management and subwoofer integration	14
HF filter	15
LF filter	15
CAL/Preset	16
Sensitivity +4 dBu/-10 dBV	16
Volume	16
<b>Custom ARC calibration</b>	17
<b>Front LED</b>	19
<b>ARC X</b>	20
<b>MTM design</b>	21
Desktop positioning	22
Listening position	23
Room acoustics	24
Microphone stand mounting	24
<b>DFU mode</b>	25
<b>Factory Reset</b>	26
<b>Troubleshooting</b>	27

<b>Specifications</b>	28
<b>Support</b>	29
IK Product Manager	29
<b>Regulatory</b>	30

## iLoud MTM MKII

Thank you for purchasing iLoud MTM MKII.

Your package contains:

- iLoud MTM MKII speaker (single)
- Power cord
- Tilting stand
- Stand's locking key
- TPU base for horizontal positioning
- Registration card

iLoud MTM MKII's innovative features and smart design re-invent studio monitoring for any kind of setup, from professional studios looking for transparent, revealing nearfields, to musicians in home and small studios looking for absolute precision from their workhorse monitors.

iLoud MTM MKII offers a flat frequency and phase response, previously unavailable on monitors even double the price of iLoud MTM MKII, to provide unbelievably revealing, true-to-life sound with no ear fatigue, that makes working on any kind of audio material a joy.

## Register your iLoud MTM MKII

To ensure that your product is running the latest firmware, we strongly recommend registering your speakers and installing ARC X app. ARC X allows you to easily check for and install firmware updates, ensuring optimal performance and access to the latest features. More information on ARC X chapter of this manual.

By registering, you can access technical support, activate your warranty and receive free JamPoints™ which will be added to your account. JamPoints™ allow you to obtain discounts on future IK purchases! Registering also keeps you informed of all the latest software updates and IK products.

How to register:

1. Download IK Product Manager from [ikmultimedia.com/pm](http://ikmultimedia.com/pm)
2. Launch IK Product Manager application and follow the online instructions
3. Use serial number found on the registration card to register your product

## Safety Instructions

- Read these instructions.
- Keep these instructions.
- Heed all warnings.
- Follow all instructions.
- Do not use this apparatus near water.
- Clean only with dry cloth.
- Do not block any ventilation openings. Install in accordance with the manufacturer's instructions.
- Do not install near any heat sources such as radiators, heat registers, stoves, or other apparatus (including amplifiers) that produce heat.
- Do not defeat the safety purpose of the polarized or grounding-type plug. A polarized plug has two blades with one wider than the other. A grounding type plug has two blades and a third grounding prong. The wider blade or the third prong are provided for your safety. If the provided plug does not fit into your outlet, consult an electrician for replacement of the obsolete outlet.
- Protect the power cord from being walked on or pinched particularly at plugs, convenience receptacles, and the point where they exit from the apparatus.
- Only use attachments/accessories specified by the manufacturer.
- Use only with the cart, stand, tripod, bracket, or table specified by the manufacturer, or sold with the apparatus. When a cart is used, use caution when moving the cart/apparatus combination to avoid injury from tip- over.
- Unplug this apparatus during lightning storms or when unused for long periods of time.
- Refer all servicing to qualified service personnel. Servicing is required when the apparatus has been damaged in any way, such as power-supply cord or plug is damaged, liquid has been spilled or objects have fallen into the apparatus, the apparatus has been exposed to rain or moisture, does not operate normally, or has been dropped.
- To reduce the risk of fire or electric shock, do not expose this apparatus to rain or moisture. The apparatus shall not be exposed to dripping or splashing and that objects filled with liquids, such as vases, shall not be placed on apparatus.
- Where the Mains plug or an appliance coupler is used as the disconnect device, the disconnect device shall remain readily operable.
- Do not overload wall outlets or extension cords beyond their rated capacity as this can cause electric shock or fire.
- No naked flame sources, such as lighted candles, should be placed on the apparatus.
- The ventilation should not be impeded by covering the ventilation openings with items, such as newspapers, table cloths, curtains, etc.
- Correct Disposal of this product. This marking indicates that this product should not be disposed with other household wastes throughout the EU. To prevent possible harm to the environment or human health from uncontrolled waste disposal, recycle it responsibly to promote the sustainable reuse of material resources. To return your used device, please use the return and collection systems or contact the retailer where the product was purchased. They can take this product for environmentally safe recycling.

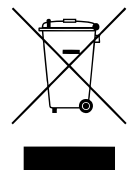

- The lightning flash with arrowhead symbol within an equilateral triangle is intended to alert the user to the presence of uninsulated “dangerous voltage” within the product’s enclosure that may be of sufficient magnitude to constitute a risk of electrical shock to persons.
- The exclamation point, within an equilateral triangle, is intended to alert the user to the presence of important operating and maintenance (servicing) instructions in the literature accompanying the product.
- **WARNING:** Do Not Open! Risk of Electrical Shock. Voltages in this equipment are hazardous to life. No user serviceable parts inside. Refer all servicing to qualified service personnel. Place the equipment near a main power supply outlet and make sure that you can easily access the power breaker switch.
- **WARNING:** This product is intended to be operated ONLY from the AC Voltages listed on the back panel or included power supply of the product. Operation from other voltages other than those indicated may cause irreversible damage to the product and void the products warranty. The use of AC Plug Adapters is cautioned because it can allow the product to be plugged into voltages in which the product was not designed to operate. If the product is equipped with a detachable power cord, use only the type provided with your product or by your local distributor and/or retailer. If you are unsure of the correct operational voltage, please contact your local distributor and/or retailer.

## Overview



1. 2 x 3,5" woofers
2. 1" back-chamber loaded tweeter
3. Multi-color indication LED
4. Integrated tilting isolation stand
5. Bass reflex port
6. Rear controls
7. Volume control
8. 1/4" / XLR combo input
9. 1/8" ARC mic input
10. USB port
11. AC power input
12. Power switch

## Installation and setup

We recommend using high quality audio cables to guarantee optimal performance.

It's important to ensure that the speakers stand firmly on a solid surface.

Note that the loudspeakers will need a few days of use to achieve optimum sonic performance.

1. Make sure that the volume control of iLoud MTM MKII is set to minimum. Make sure that the ON/OFF switch on the rear panel is set to OFF.
2. Install the adjustable foot on the bottom of the iLoud MTM MKII with the locking key. You can adjust the inclination of the speaker from 0° to 20°. Once you reach the desired inclination angle, tighten the locking key.

**IMPORTANT:** make sure that you tighten the locking key on the correct threaded insert at the bottom of iLoud MTM MKII. The second threaded insert is intended for installing the iLoud MTM MKII on a microphone stand.

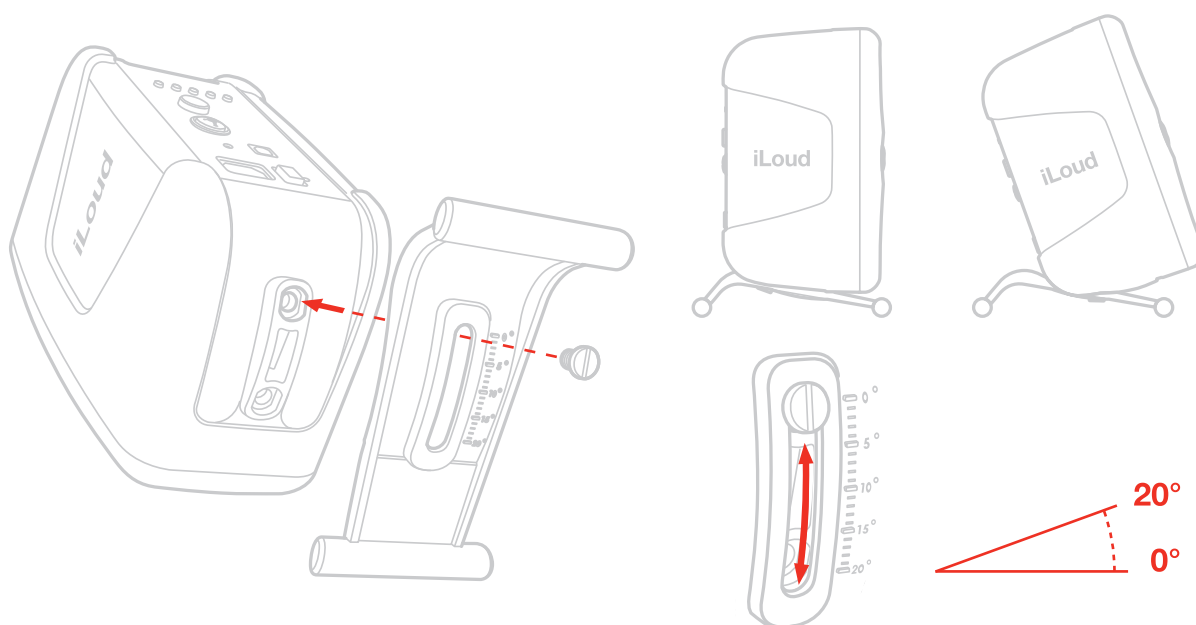

3. Adjust the vertical alignment of the speaker. This step is crucial to fully benefit from the MTM design (for more information refer to the dedicated paragraph in this manual).

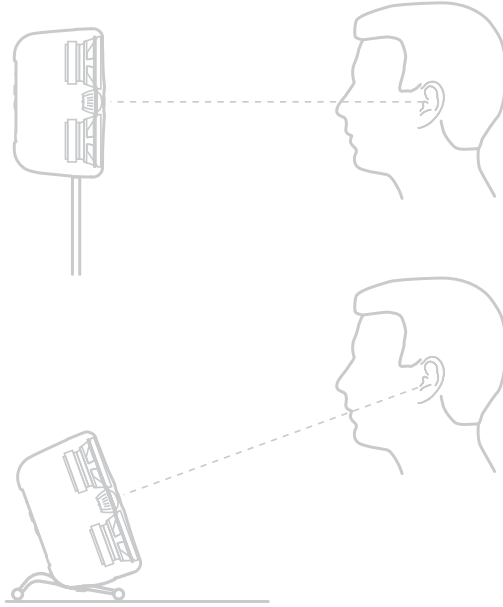

4. Connect the power cord.

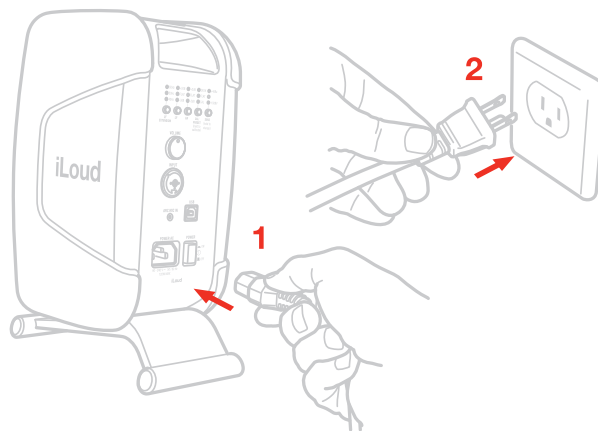

5. Connect the audio input source to the input connector of iLoud MTM MKII.

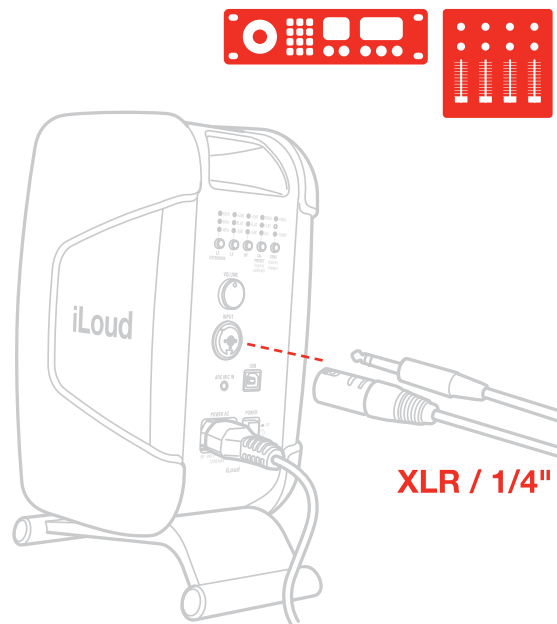

6. Switch ON the ON/OFF switch on the rear panel. The front LED will become steady white after a short delay.

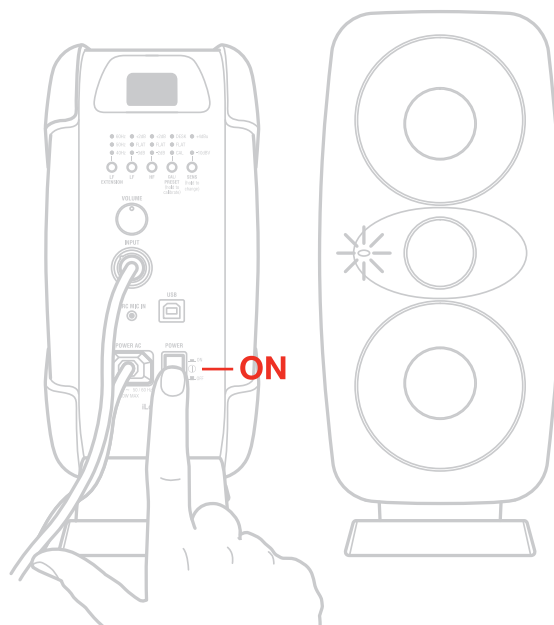

7. Turn your audio playback system on (Mixing console, Audio interface, etc.). Make sure you have set the proper input sensitivity using the SENS button, then set the volume control to 12 o'clock (center detent). This is the reference position for the SPL calibrated values in the specs. Adjust the volume control to a higher or lower position only if needed or only in case you require different levels between the speakers.
8. If needed, adjust the speaker response with the dedicated controls on the rear panel.
9. You can perform a speaker calibration to perfectly fit your iLoud MTM MKII into your acoustic environment (for more information refer to the dedicated paragraph in this manual).
10. It's possible to place the iLoud MTM MKII horizontally using the supplied TPU support, however consider this as a second option because the performance of iLoud MTM MKII is specifically optimized to work better with the acoustic environment when placed vertically. iLoud MTM MKII has a controlled vertical dispersion that will make the sweet-spot on the horizontal axis to be quite narrow when placed horizontally.

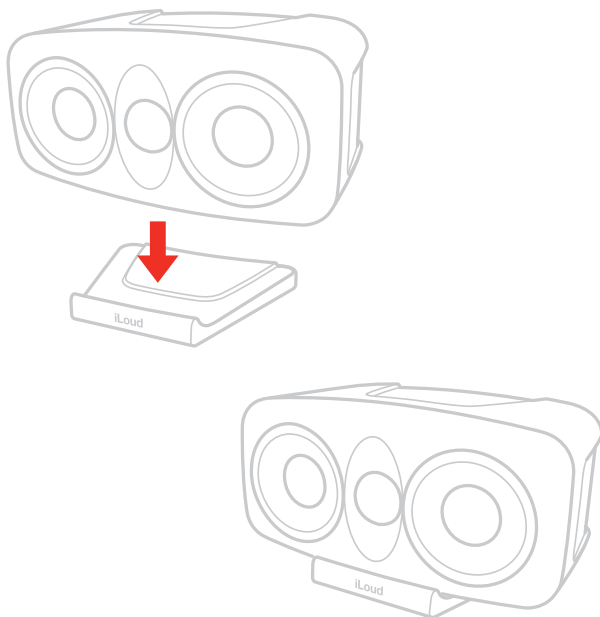

Note: Before plugging in and turning on, remember the “last on, first off” rule of powered speakers. When powering up your system, be sure that all the wires are connected, turn on your mixer/interface and any other outboard gear, and then lastly turn on your iLoud MTM MKII. When powering down, turn your iLoud MTM MKII off first and then your mixer/interface and outboard gear.

## Control panel

### Audio inputs

#### Combo XLR-1/4" balanced line input

This combo connector allows for the connection of an analog audio source (i.e., mixer/audio interface Bal/Unbal line out). Connect professional equipment with balanced outputs to the XLR or 1/4" TRS input of the speaker using balanced signal cables.

#### ARC Mic input

Use this 1/8" TS jack to connect the optional ARC microphone (not included) which will allow you to perform a custom calibration of the speaker to perfectly fit your environment.

#### USB port

The back panel features a type B USB port, designed to allow ARC X connection and firmware updates.

### Power

Power button: this pushbutton allows you to power on and off your iLoud MTM MKII.

Power AC: connect the (included) power cord to this AC socket.

**IMPORTANT:** before attempting to connect/disconnect the power cord, make sure that the power button is set to Off.

## Rear controls

The pushbuttons on the back panel will help you to perfectly match iLoud MTM MKII to every acoustic environment.

## LF extension

The LF extension button is a high-pass filter that can be set to filter out frequencies below 80 (LFE), 60 Hz, 50 Hz (default) or 40 Hz.

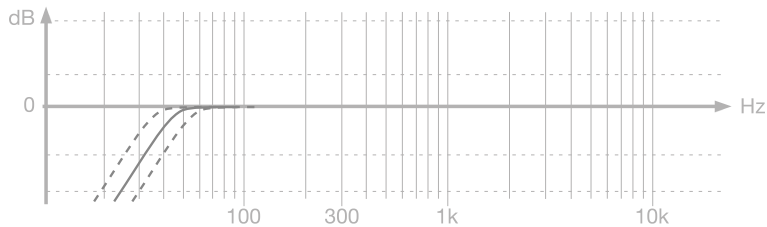

## 80 Hz low cutoff for bass management and subwoofer integration

Proper bass management can help by letting the main and surround speakers focus on the frequency range they do best and letting the subwoofers handle the low-frequency range.

Adding a standard Butterworth fourth-order filter at 80 Hz (LFE) to iLoud MTM MKII allows for quick integration with subwoofers at the frequency and slope that are considered the standard when doing bass management in multichannel or immersive setups.

To access this feature press the LF Extension button until all three LEDs are ON



## HF filter

This pushbutton controls the high frequency level using a shelf-type EQ. The level can be set to 0 dB (FLAT), +2 dB or -2 dB, from 8 kHz up.

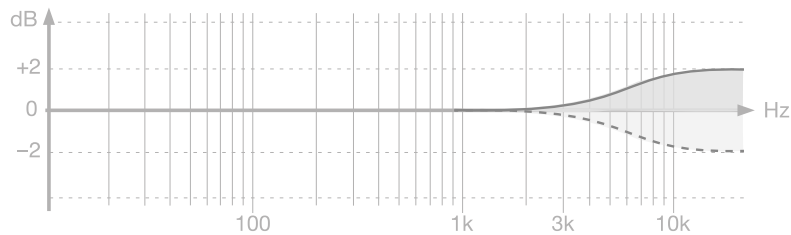

## LF filter

This pushbutton controls the low frequency level using a shelf-type EQ. The level can be set to 0 dB (FLAT), +2 dB or -3 dB, from 100 Hz down.

This filter is used to adjust the proximity effect of side walls and ceiling. Use this filter whenever the acoustics of your room cause problems in the low-frequency range.

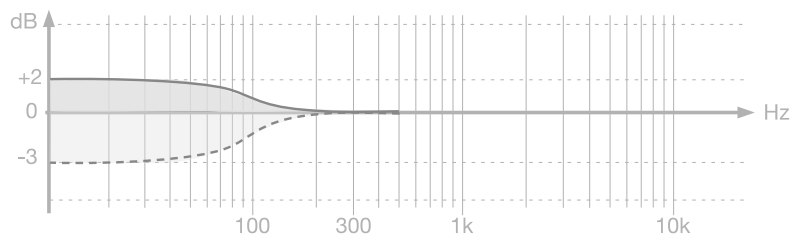

## CAL/Preset

This pushbutton allows you to cycle between Desktop filter, FLAT (default) and custom user Calibration.

The Desktop filter sets an attenuation filter to compensate for the typical acoustic effect of a console or a desk. Such placement usually results in a boost in the lower midrange.

The Desktop switch activates a bell-shaped notch filter, with a -4 dB centered at 160 Hz and +1 dB at 1.8 kHz.

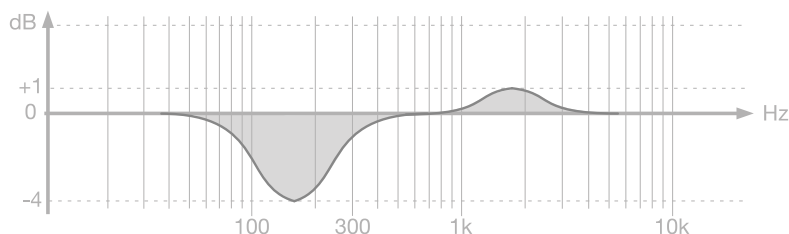

To perform a custom Calibration refer to the next paragraph.

**IMPORTANT:** units shipped from our factory have no custom calibration loaded, so the CAL position won't be available until a custom calibration has been performed by the user.

## Sensitivity +4 dBu/-10 dBV

The +4 dBu / -10 dBV input sensitivity button allows connection of the speakers to high-output professional equipment without risk of input overload. It's possible to cycle between +4 dBu and -10 dBV by holding the SENS button for more than 2 seconds. The level is set to the +4 dBu level when it ships from our factory. This setting will be best for most professional applications.

When connecting iLoud MTM MKII to consumer equipment (as for example Hi-Fi components, smartphones, tablets, Laptop computers and so on), set the level to the -10dBV setting. To determine the nominal output level of the connected equipment, consult the documentation supplied with the connected equipment.

## Volume

This control allows you to adjust the input level of the audio source from -inf dB to +6 dB.

## Custom ARC calibration

(ARC measurement mic required)

Thanks to the ARC technology, iLoud MTM MKII can be tailored to perfectly fit your listening space.

**IMPORTANT:** An ARC calibration microphone (sold separately) is necessary to proceed with the calibration.

1. Connect the ARC microphone to the ARC INPUT on the back of iLoud MTM MKII with the XLR/TS cable provided with the ARC MIC.

**IMPORTANT:** the measurement microphone must be positioned HORIZONTALLY.

Example of correct microphone positioning:

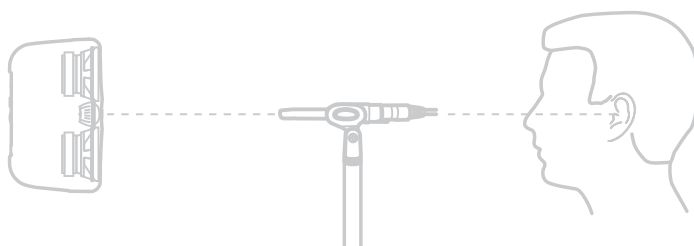

2. Place the microphone at the listening point, making sure the mic capsule aperture points towards the ceiling, and that the microphone is placed exactly in the center spot between the two speakers, at the listening position. Try to use a mic stand with a boom arm that is extended as far away from the stand as possible. This helps avoid reflections from the stand that may interfere with the analysis at high frequencies. Do not stand or sit near the microphone while the analysis procedure is running. As indicated in the figure above, the microphone has to be set at the same height where your ears are when you are listening to the speakers.

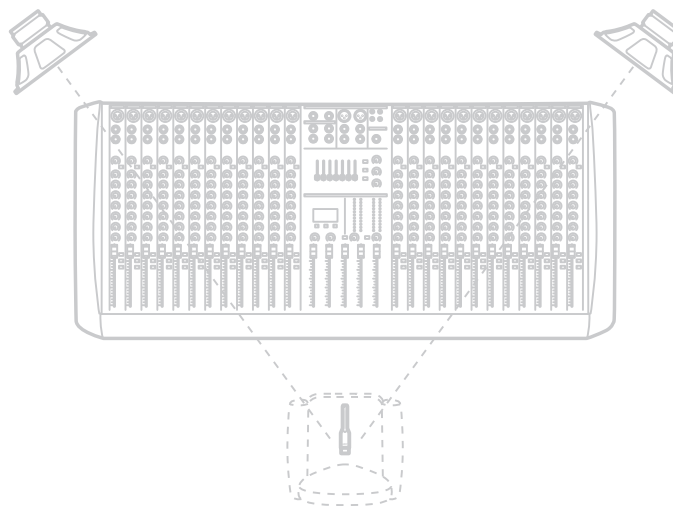

3. Keep the CAL/PRESET button pressed for three seconds to enable iLoud MTM MKII's calibration mode. The

CAL LED on the back and the front LED will start blinking.

4. Press the CAL/PRESET button to begin measurement on the current point.

After 5 seconds the speaker will emit the calibration test signals (sweeps) and the front led blinking rate will increase.

**IMPORTANT:** during the measurement process make sure that the environment is as silent as possible, do not touch the speaker or the microphone, and make sure that the overall room setup is as similar as possible to the one that will be used during normal iLoud MTM MKII usage.

5. Once the measure has been taken, the system will automatically start calculating the ARC calibration filters. If the calculation process concludes without issues, the front LED will turn green for 3 seconds to confirm the ARC calibration has been successful and that it has been stored: the system will automatically load the calibration and go back to normal operation mode.

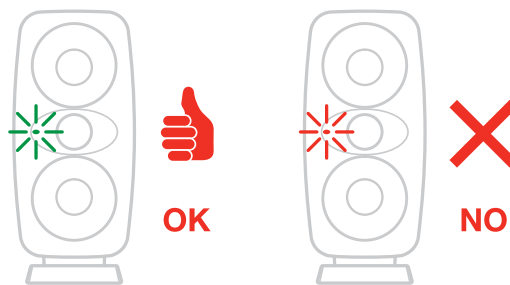

If, for any reason, the calibration ended unsuccessfully, the front LED will blink RED. Keep the CAL/PRESET button pressed for 3 seconds to exit the CAL procedure and go back to normal operation mode. Please repeat the calibration process making sure to check the ARC mic connection. If the calibration keeps failing repeatedly, please contact IK customer service.

The calibration procedure will need to be repeated for each of the speakers in the system, paying attention to place the microphone in the same spots for each position for both speakers.

NOTE: the measurement signal level is independent of the volume control. The audio test signal level is fixed and optimized for best performance.

NOTE: by using the ARC X app, you can access a high-precision calibration procedure. For more information, please refer to the ARC X user manual.

## Front LED

The front LED will show important information about iLoud MTM MKII's status.

### Operating status

- **White, steady:** The unit is operating in normal mode. At power-on, the front LED will blink blue for a short time while the unit is powering on.
- **Cyan, steady:** The unit is working in normal mode with an active voicing different than default. Please refer to ARC X manual for more informations.
- **Blue, steady:** The unit is in DFU mode. Please refer to “DFU mode” chapter.
- **Red, blinking:** unchanged
- **White, breathe effect:** ARC calibration mode is active, please refer to “Custom ARC calibration” chapter.
- **Blinking white (slow):** ARC sweep countdown, please refer to “Custom ARC calibration” chapter.
- **Blinking white (fast):** measurement calculation in progress, please refer to “Custom ARC calibration” chapter.

### Faults reporting

- **Steady red, no audio:** Irrecoverable amplifier fault. No audio will be reproduced. Turn off the unit immediately.
- **Blinking red, no audio:** Irrecoverable power supply unit fault. No audio will be reproduced. Turn off the unit immediately.

## ARC X

iLoud MTM MKII is compatible with ARC X, IK Multimedia's advanced room calibration and monitor management software. ARC X allows users to measure and calibrate their listening environment, manage speaker settings and optimize monitoring accuracy directly from a computer.



For detailed information about ARC X features and operation, please refer to the ARC X User Manual: [ikmultimedia.com/arcx](http://ikmultimedia.com/arcx)

The complete set of features includes:

- Step-by-step guided room measurement and calibration workflow.
- Automatic room correction processing.
- Real-time monitor management and speaker control.
- Before/after room response visualization.
- Flexible multi-point measurement options for different calibration detail levels.
- Calibration Session management and recall.
- Multiple target curve options and monitor voicing.
- Firmware update support.

## MTM design

The MTM (Midwoofer-Tweeter-Midwoofer) design has a very uniform and smooth horizontal dispersion, and a more controlled, narrower vertical one.

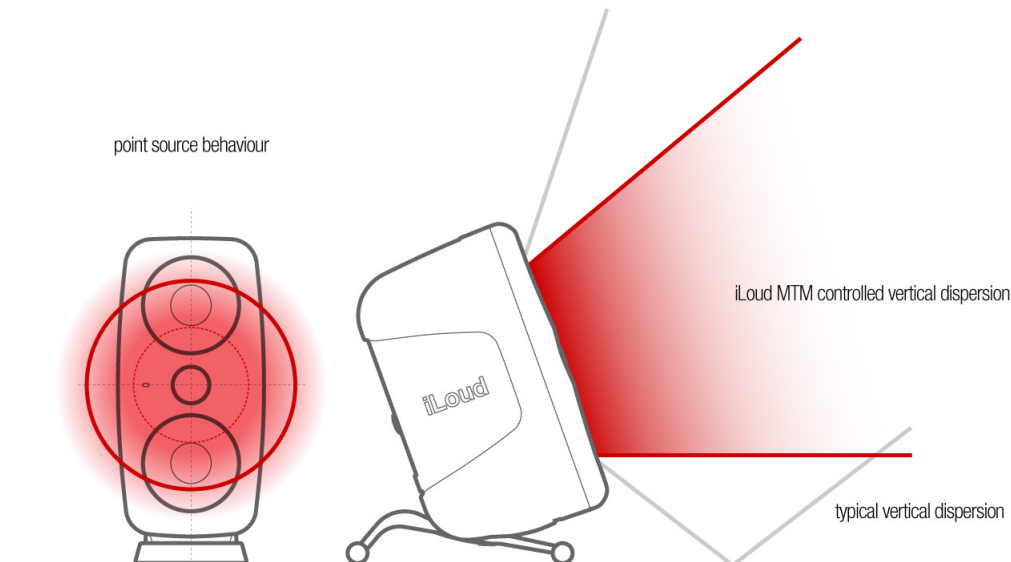

This means that:

- Ceiling and floor reflections are minimized, especially at mid and high frequencies, basically augmenting the focus that the speakers can provide.
- In the same way, reflections from a desk are less problematic (causing less comb-filtering) than with a regular 2-way TM speaker.

This also means that the vertical alignment of the speaker with the listener's ears is crucial: a bad vertical alignment can cause substantial drops in the mid and high frequencies.

For this reason, particular attention must be paid to the positioning of iLoud MTM MKII.

Make sure that no obstacles are present between the monitors and your ears. You should be able to see the speakers completely. iLoud MTM MKII has been designed for both vertical and horizontal set up. The speakers must be positioned on a firm surface or a stand.

Note that vibration of nearby objects can mask the sound.

## Desktop positioning

The center of the tweeter should be positioned approximately at the height of your ears. In case you need to position the speakers in a significant lower or higher position, the monitors should be angled accordingly. If the speakers are placed lower than the ear line, you can tilt them using the adjustable foot that also improves the acoustic decoupling of the speakers from the surface.

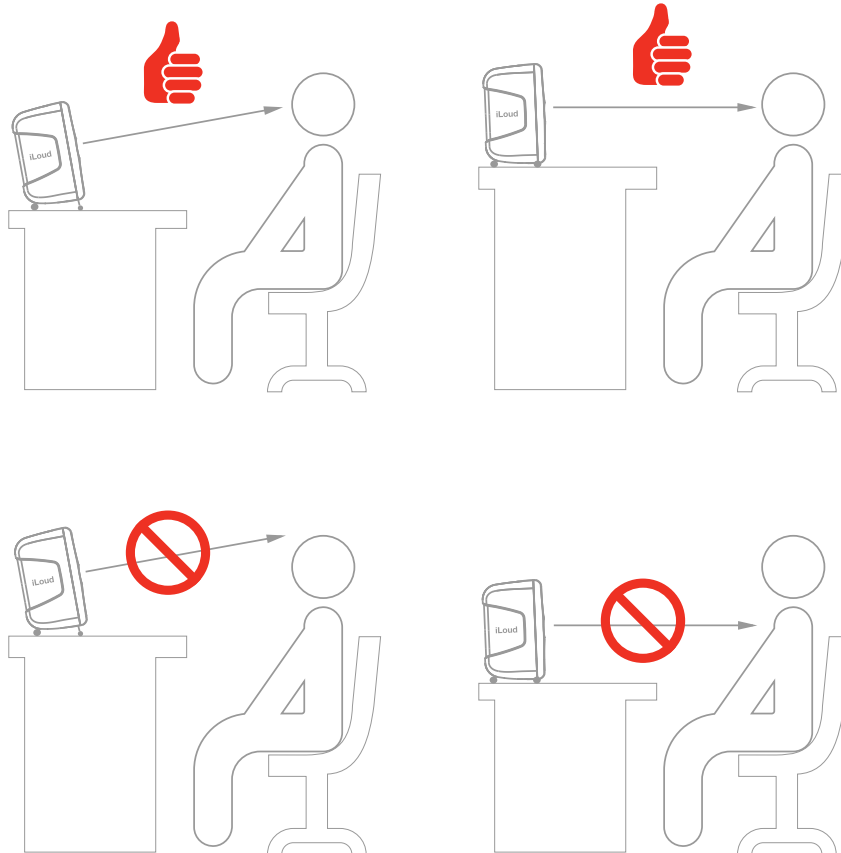

## Listening position

When you use iLoud MTM MKII for stereo applications, the optimum listening position should be located in the middle of an imaginary triangle. This means that your listening point (sweet spot) will be located at the top of an equilateral triangle and the two loudspeakers should be placed at the other two corners of this triangle.

Furthermore, a symmetrical positioning is also important: this applies to the distance between speakers as well as to the walls, ceiling and floor. In order to have a symmetrical stereo image, it's also important to have symmetrical reflections: we recommend keeping a distance of at least 20 cm (8 inches) from the walls to avoid low-frequency emphasis.

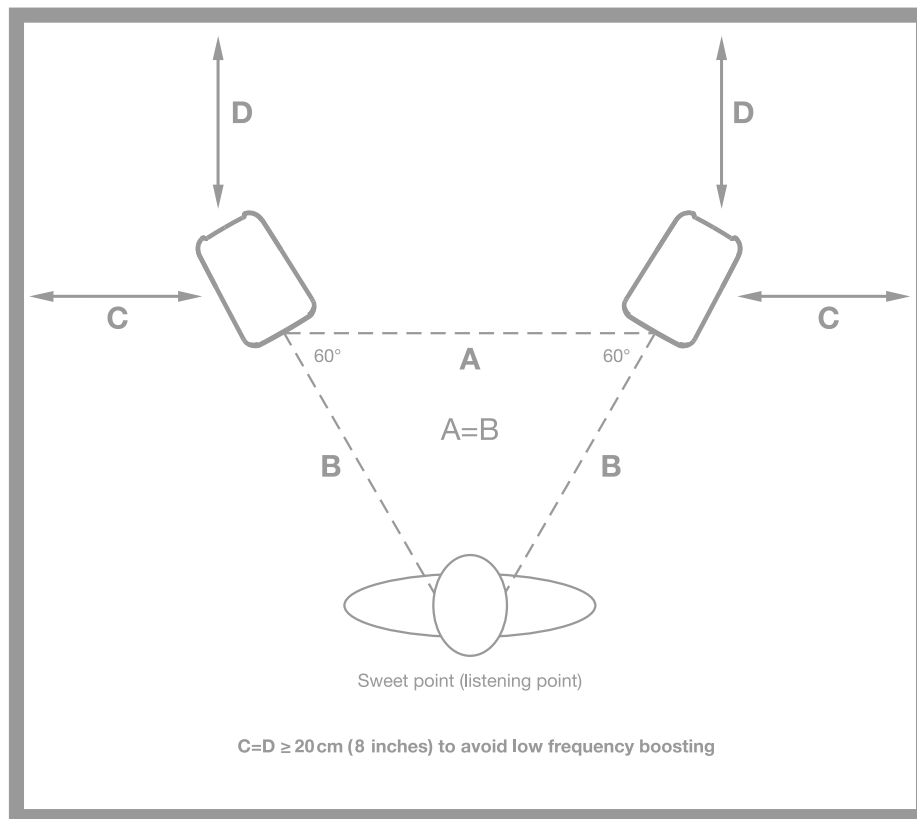

## Room acoustics

The room acoustics plays a key role in the performance of your monitoring system. It's always advisable to make, at least, a minimum of acoustic treatment of your environment. This, along with the correct monitor positioning, will improve the linearity and the precision of the listening experience.

## Microphone stand mounting

Thanks to the thread adapter on the bottom of the speaker, iLoud MTM MKII can be mounted on any standard 3/8" microphone stand. This allows you to place the speakers at the perfect height and, most important, helps to reduce the typical reflections of the desktop (or shell) and, consequently, improves the frequency response/linearity of the speaker.



### **DFU mode**

Firmware updates of your iLoud MTM MKII are managed by the ARC X control software available for download on IK Product Manager after registering your unit.

In the unfortunate event of an unsuccessful firmware update (I.E. in case of a power loss) the unit could experience issues and be unable to start up properly.

Booting the device in DFU mode will allow the ARC X app to perform a firmware recovery procedure and restore the unit to proper working conditions (please refer to ARC X app manual for detailed information on firmware recovery procedure).

To boot iLoud MTM MKII in DFU mode, hold the LF EXT button and plug the power cord to the unit. The front LED will turn steady blue to indicate DFU mode is active.

To exit DFU mode, disconnect the power cord and wait until the front LED turns off.

Re-connect the power cable and the unit should power up in normal mode.

## Factory Reset

To perform a factory reset, keep pressed both the CAL/PRESET and SENS buttons for more than 5 seconds.

After this time all the LED's will flash for 3 seconds and all the controls will be returned to the factory status, the voicing will be reset to default and any custom Calibration will be erased.

## Troubleshooting

I have connected my device to iLoud MTM MKII but no sound comes out

Make sure to set up the volume with the volume control on iLoud MTM MKII and/or with your device's volume control.

Sound is distorted

When noticeable distortion occurs, please turn down the level of the speakers, or of the connected audio source.

Calibration ended unsuccessfully (front LED blinks red)

If the calibration ends unsuccessfully and the front LED blinks red, make sure you have correctly inserted the XLR cable both on the microphone and on the 1/8" ARC mic input on the rear of iLoud MTM MKII.

## Specifications

- Type: 2-Way/3-speakers bi-amped, digitally controlled studio monitor
- LF drivers: 2 x 3.5" composite cellulose fiber, custom-made mid-woofers
- HF drivers: 1" low distortion, back chambered silk dome tweeter
- Acoustic design: DSP tuned bass reflex
- Number of amps per speaker: 2
- Amplifiers type: High efficiency Class-D
- Total power: 100 W RMS
- LF power: 70 W RMS
- HF power: 30 W RMS
- Crossover type: Digital, linear phase
- Crossover frequency: 2.8 kHz
- Frequency response: 48 Hz to 28 kHz  $\pm$  2 dB, 36 Hz to 32 kHz @ -10 dB
- Phase response: System remains coherent within  $\pm$  15° from 200 Hz to 20 kHz
- Sensitivity at +4 dBu: -6 dBu signal generates a 94 dB SPL @ 1 m
- Sensitivity at -10 dBV: -17 dBu signal generates a 94 dB SPL @ 1 m
- Continuous, long term SPL free field, 1 m distance, one speaker, ANSI-2034 Weigthed Pink Noise: 97 dB
- Peak SPL free field, 1 m distance, one speaker, ANSI-2034 Weigthed Pink Noise: 110.5 dB
- Peak SPL, half space, 1 m distance, one speaker, ANSI-2034 Weigthed Pink Noise: 112.5 dB
- Placement setup: Manual switches for LF Extension, LF trim, HF trim, Desk position
- LF extension switch: Sets -3 dB point of the frequency response at 40, 50, 60 or 80 Hz (LFE)
- LF switch: Low shelf, +2 dB or -3 dB from 100 Hz down
- HF switch: High shelf, +2 dB or -3 dB from 8 kHz up
- Desk switch: -4 dB at 160 Hz and +1 dB at 1.8 kHz
- Calibration: Fully automatic and built-in digital calibration
- Full DSP control
- Total Latency (TOF): 2.44 ms
- Connectors: 1x combo XLR-1/4" TRS balanced input; 1/8" TS ARC microphone input, 1 x USB type-B, AC POWER socket
- Power requirement: 90 to 240 V AC, auto-ranging, 50 or 60 Hz, 120 W max power consumption
- Dimensions: 264 mm/(10.39") x 160 mm/(6.3") x 130 mm/(5.12")
- Weight : 2.5 kg including tilting base (5.5 lb)

## Support

For any questions you may have, please refer to the FAQ webpage at:

[ikmultimedia.com/faq](http://ikmultimedia.com/faq)

Here you will find answers to the most commonly asked questions.

To submit a Technical Support Form, go to:

[ikmultimedia.com/support](http://ikmultimedia.com/support)

For warranty information, please visit:

[ikmultimedia.com/warranty](http://ikmultimedia.com/warranty)

For other requests such as Product, Sales, or Web info, please go to:

[ikmultimedia.com/contact-us](http://ikmultimedia.com/contact-us)

## IK Product Manager

The IK Product Manager gives you one central location to manage all the latest IK Multimedia products. It's your central command for registration, downloads, installation, authorization, checking for updates, and much more.

- Register hardware and software in one location
- Download, install, and authorize software
- Simplified sounds download with pause/resume
- Authorize and de-authorize computers
- Update software, sounds and firmware
- Easily manage your entire IK collection

Download IK Product manager at:

[ikmultimedia.com/pm](http://ikmultimedia.com/pm)

## Regulatory

Studio Monitor - IK000100

Model: iLoud MTM MKII

U.S.A.



FCC statement

This device complies with Part 15.107 and 15.109 Class B of the FCC Rules CFR47: October 2010.

Operation is subject to the following two conditions:

1. This device may not cause harmful interference.
2. This device must accept any interference received, including interference that may cause undesired operation.

Changes or modifications not expressly approved by the party responsible for compliance could void the user's authority to operate the equipment.

EUROPE



AUSTRALIA/NEW ZEALAND



JAPAN



**IK Multimedia Production Srl**

Via dell'Industria, 46,  
41122 Modena  
Italy

**IK Multimedia US, LLC**

590 Sawgrass Corporate Pkwy.  
Sunrise, FL 33325  
USA

**[www.ikmultimedia.com](http://www.ikmultimedia.com)**

iLoud® MTM is a trademark property of IK Multimedia Production Srl.. All rights reserved.

All other product names and images, trademarks and artists names are the property of their respective owners, which are in no way associated or affiliated with IK Multimedia. Product names are used solely for the purpose of identifying the specific products that were studied during IK Multimedia's sound model development and for describing certain types of tones produced with IK Multimedia's digital modeling technology. Use of these names does not imply any cooperation or endorsement.

All specifications are subject to change without further notice.

Document Version: 1.2.0

Latest Update: 2026/06/08

© 2019-2026 IK Multimedia. All rights reserved.

